

TM 10-5411-236-13&P

TECHNICAL MANUAL

OPERATOR, UNIT, AND DIRECT SUPPORT
MAINTENANCE MANUAL
(INCLUDING REPAIR PARTS & SPECIAL TOOL LIST)
FOR

AUTHORIZED STOCKAGE LIST MOBILITY SYSTEM (ASLMS)

MODEL NUMBER FPU-8/12 PARTS (OD) P/N 15005002-001
NSN 5411-01-523-2071

MODEL NUMBER FPU-8/12 PARTS (DS) P/N 15005002-002
NSN 5411-01-523-2072

MODEL NUMBER FPU-8/12 BULK (OD) P/N 15005001-001
NSN 5411-01-523-2073

MODEL NUMBER FPU-8/12 BULK (DS) P/N 15005001-002
NSN 5411-01-523-2074

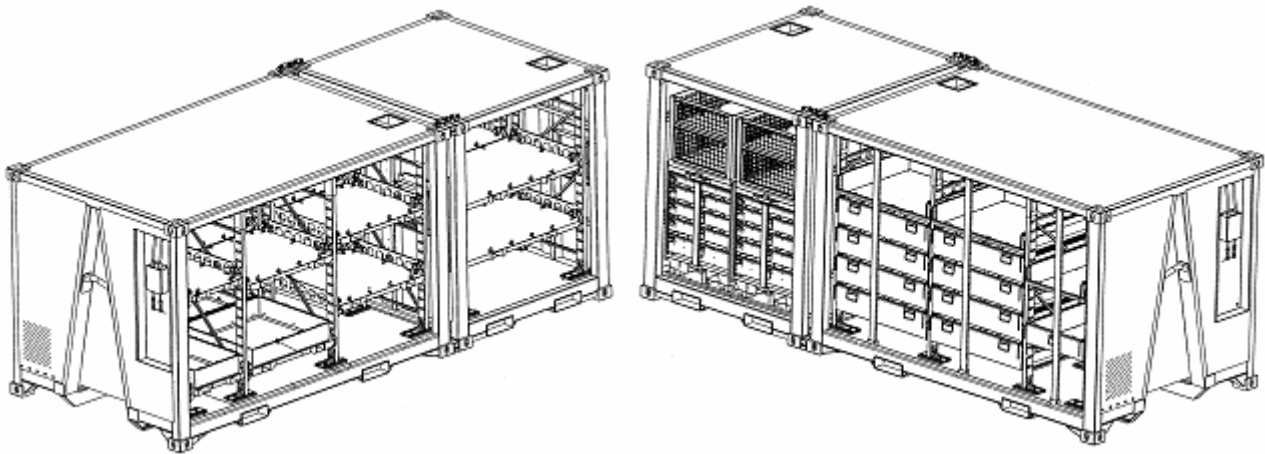

DISTRIBUTION STATEMENT A. - Approved for public release, distribution is unlimited.

HEADQUARTERS, DEPARTMENT OF THE ARMY

28 FEBRUARY 2005

GENERAL WARNINGS



HEAVY PARTS - heavy object on human figure shows that heavy parts present a danger to life or limb.



HEAVY PARTS - heavy object pinning human figure against wall shows that heavy, moving parts present a danger to life or limb.



HEAVY PARTS - hand with heavy object on top shows that heavy parts can crush and harm.



HEAVY PARTS - foot with heavy object on top shows that heavy parts can crush and harm.



SLICK FLOOR - wavy line on floor with legs prone shows that slick floor presents a danger for slipping or falling.



HEAVY OBJECT - human figure stooping over heavy object shows physical injury potential from improper lifting technique.



ELECTRICAL - electrical wire to arm with electricity symbol running through human body shows that shock hazard is present.



ELECTRICAL - electrical wire to hand with electricity symbol running through hand shows that shock hazard is present.



CRYOGENIC - hand in block of ice shows that the material is extremely cold and can injure human skin or tissue.



FIRE - flame shows that a material may ignite and cause burns.



VAPOR - human figure in a cloud shows that material vapors present a danger to life or health.



CHEMICAL - drops of liquid on hand shows that the material will cause burns or irritation to human skin or tissue.



EYE PROTECTION - person with goggles shows that the material will injure the eyes.

WARNING SUMMARY

This warning summary contains general safety warnings and hazardous materials warnings that must be understood and applied during operation and maintenance of this equipment. Failure to observe these precautions could result in serious injury or death to persons using equipment.



WARNING

Do not allow the system to swing if using an overhead lift. Always ensure an appropriate sling is used in the lift. Always use properly sized forklift, crane, or lifting device. Failure to comply could cause injury or damage to the equipment.



WARNING

Use extreme caution when connecting Field Pack-Up Unit (FPU) containers into a combination system. Forklift support is required. Make sure all container connectors are properly seated and locked secure. Failure to comply could cause serious injury. Failure to follow proper connection procedures may result in damage to the equipment.

Standard forklift principles apply when working with or on the FPU container. When working with ground guides during the loading or unloading of a module, never move the module into the FPU container while the ground guide is between the fork, module, and the FPU container. Serious injury could occur if the ground guide is pinned between the forklift and the FPU container. Forklift operators must maintain visual contact with their ground guides at all time.

Always follow standard forklift procedures. A tilt hazard exists when forklift operators try to lift a partially loaded FPU container from the wrong side. Always lift a container with the heavier side closest to the forklift operator. This places the heavier part of the load back into the tines versus out on the tips. A tilt situation exists when the heaviest part of the load is out on the tips of the tines, on uneven ground, with forks fully extended, and while traveling. Operators should always keep loads low and close to the forklift carriage. Operators should never travel when the load is in the fork's extended position.



WARNING

The modules and their contents are heavy and could cause injury if they fall onto or strike personnel. A tilt hazard exists when the module is either outside of the FPU-8 container or inside the FPU container, but not locked down. As a rule, always work on one pallet or drawer at a time. Never have more than one drawer extended in the full open position at a time, especially if loaded. Personnel should never stand on a drawer or pallet.



WARNING

Fall hazards exist when climbing onto or working from the top of the container. Always maintain three points of contact to the ladder and container when climbing onto the container. Never move, step, or walk backwards when working on top of the system. All movement should be in the forward direction. A fall can occur if personnel lose concentration and step backwards off of the edge. Stand erect only if necessary and only away from the edge. Working from a kneeling position helps reduce the threat of a fall.

The FPU may be used to store various forms of oils, lubricants, and other potentially slippery substances. Keeping the inside floor of the ASLMS clean is important, nevertheless always move with caution inside of the ASLMS. Failure to maintain cleanliness and caution could cause a slip and injury.



WARNING

The module drawers and pallets can be heavy and awkward to handle by a single person. This is especially true of the larger components. The adjustment of these items is a two-person operation. While a forklift is not essential MHE support to hold the pallets in position while the hardware is installed and secured, it simplifies the effort. Do not try to adjust the pallets or drawers without assistance or MHE support.

ISO Container Overhead Power Line Warning.



WARNING

Overhead power lines and obstructions can cause serious injury or damage to property. Forklift operators, truck drivers, and ground guides should always clear overhead when loading, unloading, or moving the ASLMS containers.



WARNING

To prevent electrical shock hazard, only trained and qualified personnel should attempt to correct electrical discrepancies. Additionally electrical power must be disconnected before any electrical system work is performed.



WARNING

Protective gloves should be worn when handling metal parts in below freezing temperatures. Failure to wear gloves may result in skin freezing to the metal upon contact and cause tearing of the flesh when attempting to pull away from the metal.



WARNING

Dry cleaning solvent is flammable and cannot be used near an open flame. Use only in well-ventilated places and have a fire extinguisher available. Use protective clothing as directed in the product MSDS is required. Failure to comply could result in injury or equipment damage. Do not allow cleaning solvents or compounds to come in contact with door seals, covers, fabric, or rubber components. Damage to these components will occur.



WARNING

The ASLMS is NOT designed to be operated in contaminated NBC environments. Do not operate the ASLMS in contaminated NBC environments. If possible cease operation of the ALSMS prior to a NBC event and do the following:

- Remove and store the EPC in the ASLMS (refer to WP 009 00).
- Reduce the ASLMS to its transportation configuration with ventilation and access doors closed.

External surfaces of the ASLMS FPU are CARC painted and can be decontaminated, however, whenever possible avoid contamination of the internal areas of the ASLMS FPU.

Decontaminate the exterior surfaces of the ASLMS in accordance with FM 3-5. Qualified NBC NCOs should check for residual contamination before opening the container. Remain in MOPP 4 posture when opening the doors and have the NBC NCO check for contamination on interior surfaces. If thorough decontamination is required refer to NBC NCO and FM 3-5 for procedures.

TM 10-5411-236-13&P

**CHANGE
NO. 1**

**HEADQUARTERS, DEPARTMENT OF THE ARMY
WASHINGTON, DC, 22 November 2006**

TECHNICAL MANUAL

**OPERATOR, UNIT AND DIRECT SUPPORT
MAINTENANCE MANUAL
(INCLUDING REPAIR PARTS AND SPECIAL TOOLS LIST)
FOR**

**AUTHORIZED STOCKAGE LIST MOBILITY SYSTEM (ASLMS) MODEL NUMBER FPU-9/12
PARTS (OD) P/N 15005002-001 (NSN 5411-01-523-2071) MODEL NUMBER FPU-812 PARTS
(DS) P/N 15005002-002 (NSN 5411-01-523-2072) MODEL NUMBER FPU-8/12 BULK (OD) P/N
15005001-001 (NSN) 5411-01-523-2073) MODEL NUMBER FPU-8/12 BULK (DS) P/N 15005001-
002 (NSN 5411-01-523-2074)**

DISTRIBUTION STATEMENT A: - Approved for public release; distribution is unlimited.

TM 10-5411-236-13&P, 28 February 2005, is updated as follows:

1. File this sheet in front of the manual for reference.
2. This change is a result of DA Form 1028 requests from equipment specialists, correcting grammatical errors and ambiguous wording; clarifying some maintenance procedures by changing text and adding illustration support; and adding NSNs to RPSTL.
3. New or updated change information is indicated by a vertical bar in the outer margin of the page.
4. Remove old pages and insert new pages as indicated below:

Remove Pages

A/(B Blank)
a-f

Insert Pages

A/(B Blank)
a-f

5. Replace the following work packages with their revised version:

<u>Work Package Number</u>	<u>Work Package Number</u>	<u>Work Package Number</u>	<u>Work Package Number</u>
WP 0002 00	WP 0067 00	WP 0080 00	WP 0098 00
WP 0004 00	WP 0068 00	WP 0081 00	WP 0099 00
WP 0005 00	WP 0069 00	WP 0082 00	WP 0101 00
WP 0006 00	WP 0070 00	WP 0083 00	WP 0102 00
WP 0007 00	WP 007100	WP 0084 00	
WP 0008 00	WP 0072 00	WP 0085 00	
WP 0009 00	WP 0073 00	WP 0086 00	
WP 0010 00	WP 0074 00	WP 0087 00	
WP 0012 00	WP 0075 00	WP 0088 00	
WP 0051 00	WP 0076 00	WP 0094 00	
WP 0052 00	WP 0077 00	WP 0095 00	
WP 0065 00	WP 0078 00	WP 0096 00	
WP 0066 00	WP 0079 00	WP 0097 00	

ARMY TM 10-5411-236-13&P

C1

By Order of the Secretary of the Army:

PETER J. SCHOOMAKER
General, United States Army
Chief of Staff

Official:

JOYCE E. MORROW
*Administrative Assistant to the
Secretary of the Army*
0631203

Distribution: To be distributed in accordance with initial distribution number (IDN) 256825 requirements for TM 10-5411-236-13&P.

INSERT LATEST CHANGED PAGES/WORK PACKAGES. DESTROY SUPERSEDED DATA.

LIST OF EFFECTIVE PAGES/WORK PACKAGES

NOTE: The portion of text affected by the change is indicated by a vertical line in the outer margins of the page. Changes to illustrations are indicated by a bar adjacent to the title. Zero in the "Change No." column indicates an original page or work package.

Dates of issue for original manual and changed pages / work packages are:

Original 28 February 2005
Change 1 22 November 2006

TOTAL NUMBER OF PAGES FOR FRONT AND REAR MATTER IS 24 AND TOTAL NUMBER OF WORK PACKAGES IS 105, CONSISTING OF THE FOLLOWING:

Page/WP No.	Change No.	Page/WP No.	Change No.	Page/WP No.	Change No.
Front Cover	0	WP 0031 00 (4 pgs)	0	WP 0068 00 (4 pgs)	1
a-f	1	WP 0032 00 (2 pgs)	0	WP 0069 00 (4 pgs)	1
i-vi	0	WP 0033 00 (4 pgs)	0	WP 0070 00 (4 pgs)	1
Chp 1 title page	0	WP 0034 00 (4 pgs)	0	WP 0071 00 (4 pgs)	1
WP 0001 00 (2 pgs)	0	WP 0035 00 (2 pgs)	0	WP 0072 00 (4 pgs)	1
WP 0002 00 (4 pgs)	1	WP 0036 00 (4 pgs)	0	WP 0073 00 (4 pgs)	1
WP 0003 00 (4 pgs)	0	WP 0037 00 (2 pgs)	0	WP 0074 00 (4 pgs)	1
WP 0004 00 (4 pgs)	1	WP 0038 00 (2 pgs)	0	WP 0075 00 (4 pgs)	1
Chp 2 title page	0	WP 0039 00 (2 pgs)	0	WP 0076 00 (4 pgs)	1
WP 0005 00 (20 pgs)	1	WP 0040 00 (2 pgs)	0	WP 0077 00 (4 pgs)	1
WP 0006 00 (20 pgs)	1	WP 0041 00 (2 pgs)	0	WP 0078 00 (4 pgs)	1
WP 0007 00 (12 pgs)	1	WP 0042 00 (2 pgs)	0	WP 0079 00 (6 pgs)	1
WP 0008 00 (6 pgs)	1	WP 0043 00 (2 pgs)	0	WP 0080 00 (4 pgs)	1
WP 0009 00 (12 pgs)	1	WP 0044 00 (2 pgs)	0	WP 0081 00 (4 pgs)	1
WP 0010 00 (4 pgs)	1	WP 0045 00 (2 pgs)	0	WP 0082 00 (4 pgs)	1
Chp 3 title page	0	WP 0046 00 (2 pgs)	0	WP 0083 00 (4 pgs)	1
WP 0011 00 (2 pgs)	0	WP 0047 00 (6 pgs)	0	WP 0084 00 (4 pgs)	1
WP 0012 00 (4 pgs)	1	WP 0048 00 (4 pgs)	0	WP 0085 00 (4 pgs)	1
WP 0013 00 (8 pgs)	0	WP 0049 00 (2 pgs)	0	WP 0086 00 (4 pgs)	1
Chp 4 title page	0	WP 0050 00 (2 pgs)	0	WP 0087 00 (4 pgs)	1
WP 0014 00 (2 pgs)	0	Chp 6 title page	0	WP 0088 00 (4 pgs)	1
WP 0015 00 (2 pgs)	0	WP 0051 00 (4 pgs)	1	WP 0089 00 (4 pgs)	0
WP 0016 00 (2 pgs)	0	WP 0052 00 (2 pgs)	1	WP 0090 00 (4 pgs)	0
WP 0017 00 (6 pgs)	0	WP 0053 00 (8 pgs)	0	WP 0091 00 (4 pgs)	0
WP 0018 00 (2 pgs)	0	WP 0054 00 (4 pgs)	0	WP 0092 00 (4 pgs)	0
WP 0019 00 (2 pgs)	0	WP 0055 00 (4 pgs)	0	WP 0093 00 (4 pgs)	0
WP 0020 00 (2 pgs)	0	WP 0056 00 (2 pgs)	0	WP 0094 00 (4 pgs)	1
WP 0021 00 (2 pgs)	0	WP 0057 00 (4 pgs)	0	WP 0095 00 (4 pgs)	1
WP 0022 00 (2 pgs)	0	WP 0058 00 (4 pgs)	0	WP 0096 00 (4 pgs)	1
WP 0023 00 (2 pgs)	0	WP 0059 00 (2 pgs)	0	WP 0097 00 (4 pgs)	1
WP 0024 00 (2 pgs)	0	WP 0060 00 (2 pgs)	0	WP 0098 00 (6 pgs)	1
WP 0025 00 (2 pgs)	0	Chp 7 title page	0	WP 0099 00 (4 pgs)	1
Chp 5 title page	0	WP 0061 00 (2 pgs)	0	WP 0100 00 (2 pgs)	0
WP 0026 00 (2 pgs)	0	WP 0062 00 (4 pgs)	0	WP 0101 00 (4 pgs)	1
WP 0027 00 (2 pgs)	0	WP 0063 00 (8 pgs)	0	WP 0102 00 (8 pgs)	1
WP 0028 00 (2 pgs)	0	WP 0064 00 (8 pgs)	0	WP 0103 00 (4 pgs)	0
WP 0029 00 (2 pgs)	0	WP 0065 00 (4 pgs)	1	WP 0104 00 (2 pgs)	0
WP 0030 00 (2 pgs)	0	WP 0066 00 (4 pgs)	1	WP 0105 00 (2 pgs)	0
		WP 0067 00 (6 pgs)	1	Back Cover	0

HEADQUARTERS,
DEPARTMENT OF THE ARMY
WASHINGTON, D.C., 28 FEBRUARY 2005

TECHNICAL MANUAL

**OPERATOR, UNIT, AND DIRECT SUPPORT MAINTENANCE MANUAL
(INCLUDING REPAIR PARTS & SPECIAL TOOL LIST)
FOR
AUTHORIZED STOCKAGE LIST MOBILITY SYSTEM**

**MODEL NUMBER FPU-8/12 Parts (OD) P/N 15005002-001
NSN 5411-01-523-2071**

**MODEL NUMBER FPU-8/12 Parts (DS) P/N 15005002-002
NSN 5411-01-523-2072**

**MODEL NUMBER FPU-8/12 Bulk (OD) P/N 15005001-001
NSN 5411-01-523-2073**

**MODEL NUMBER FPU-8/12 Bulk (DS) P/N 15005001-002
NSN 5411-01-523-2074**

REPORTING ERRORS AND RECOMMENDING IMPROVEMENTS

You can help improve this manual. If you find any mistakes or if you know of a way to improve the procedures, please let us know. Mail your letter or DA Form 2028 (Recommended Changes to Publications and Blank Forms), or DA Form 2028-2, located in the back of this manual, directly to: Commander, U.S. Army Tank-automotive & Armament Command, ATTN: AMSTA-LC-CECT, Kansas St, Natick, MA 01760. You may also send in your recommended changes by E-mail directly to: amssbriml@natick.army.mil. A reply will be furnished directly to you. Instructions for sending electronic 2028 may be found at the back of this manual immediately preceding the hard copy 2028.

DISTRIBUTION STATEMENT A - Approved for public release; distribution is unlimited.

TABLE OF CONTENTS

	<u>WP Sequence No.</u>
WARNING SUMMARY	a
HOW TO USE THIS MANUAL.....	v
CHAPTER 1. INTRODUCTORY INFORMATION WITH THEORY OF OPERATION	
General Information	0001 00
Equipment Description and Data	0002 00
Equipment Data Labels, Identifications, Markings and Airlift Certification.....	0003 00
Theory of Operation	0004 00

CHAPTER 2. OPERATOR INSTRUCTIONS

Preparation for Movement	0005 00
Operation of ASLMS Containers.....	0006 00
Loading/Unloading ASLMS Modules	0007 00
Operating ASLMS Electrical Components.....	0008 00
Operation of the Element Protective Cover (EPC)	0009 00
Operation Under Unusual Conditions	0010 00

=====

CHAPTER 3. TROUBLESHOOTING PROCEDURES

Introduction	0011 00
Troubleshooting Indexes.....	0012 00
Troubleshooting Procedures.....	0013 00

=====

CHAPTER 4. OPERATOR MAINTENANCE INSTRUCTIONS

Service Upon Receipt	0014 00
Preventive Maintenance Checks and Services (PMCS) Introduction.....	0015 00
Preventive Maintenance Checks and Services (PMCS).....	0016 00
Cleaning, Lubricating and Spot Painting.....	0017 00
Door Assembly (FPU-12).....	0018 00
Folding Steps	0019 00
Vertical Rack Frame.....	0020 00
Constraint Bar	0021 00
Pallet	0022 00
Pallet Ledge	0023 00
Door Assembly (FPU-8).....	0024 00
ASLMS Module (FPU-8)	0025 00

=====

CHAPTER 5. UNIT MAINTENANCE INSTRUCTIONS

Door Assembly (FPU-12).....	0026 00
Folding Steps	0027 00
Vertical Rack Frame (FPU-12).....	0028 00
Constraint Bar (FPU-12)	0029 00
Drawer Assembly (FPU-12)	0030 00
Slide (FPU-12)	0031 00
Pallet / Cargo Net Floor.....	0032 00
Pallet Ledge	0033 00
Floor Adapter Plate (FPU-8)	0034 00
ASLMS Module (FPU-8)	0035 00
Rear Roller Assembly	0036 00
Connector Kit	0037 00
Fork Pocket Adapter Plug	0038 00
Distribution Box	0039 00

A/C	0040 00
Transformer.....	0041 00
Cable A/C.....	0042 00
Receptacle GFCI.....	0043 00
D/C	0045 00
Cable D/C.....	0044 00
12-Volt Light Assembly	0046 00
Vent System.....	0047 00
Vent Filter.....	0048 00
Element Protective Cover (EPC) Securing Kit.....	0049 00
EPC	0050 00

CHAPTER 6. DIRECT SUPPORT MAINTENANCE INSTRUCTION

Door Assemblies	0051 00
Vertical Rack Frame.....	0052 00
Distribution Boxes	0053 00
Transformer.....	0054 00
12-Volt Light Assembly	0055 00
Door Seals	0056 00
Cable A/C.....	0057 00
Cable D/C.....	0058 00
EPC Assembly	0059 00
Pallet Ledge	0060 00

CHAPTER 7. SUPPORTING INFORMATION

References.....	0061 00
Maintenance Allocation Chart (MAC) Introduction	0062 00
Maintenance Allocation Chart (MAC).....	0063 00
Repair Parts & Special Tools List Introduction	0062 00
GROUP 00 ASLMS FPU 8/12	0065 00
GROUP 01 FPU-12 Parts and Bulk Container	0066 00
GROUP 0101 Door Assemblies.....	0067 00
GROUP 0102 Vertical Rack Frame	0068 00
GROUP 0103 EPC Pole Storage.....	0069 00
GROUP 010401 Constraint Bar.....	0070 00
GROUP 010402 Drawer Assemblies.....	0071 00
GROUP 010403 Drawer Slides	0072 00
GROUP 010501 Pallet / Cargo Nets.....	0073 00
GROUP 010502 Pallet Ledge.....	0074 00
GROUP 02 FPU-8 Container Parts and Bulk	0075 00
GROUP 0201 Door Assemblies.....	0076 00
GROUP 0202 Rear Roller Assembly.....	0077 00
GROUP 020301 Floor Adapter Plate.....	0078 00
GROUP 020302 ASLMS Module.....	0079 00
GROUP 020401 Vertical Rack Frame	0080 00
GROUP 020402 Pallet / Cargo Nets.....	0081 00

GROUP 020403 Pallet Ledge.....	0082 00
GROUP 03 Folding Steps.....	0083 00
GROUP 04 Connector Kit.....	0084 00
GROUP 0401 Load Rail Connector Assembly.....	0085 00
GROUP 05 Fork Pocket Plug Assembly.....	0086 00
GROUP 0601 Distribution Boxes.....	0087 00
GROUP 0602 Transformer.....	0088 00
GROUP 060301 Cable A/C 150'.....	0089 00
GROUP 060302 Cable A/C 9'.....	0090 00
GROUP 060303 Receptacle GFCI.....	0091 00
GROUP 060401 Cable D/C.....	0092 00
GROUP 060402 12 Volt Light Assembly.....	0093 00
GROUP 060403 Light Pole Assembly.....	0094 00
GROUP 07 Vent System.....	0095 00
GROUP 0701 Vent Filter.....	0096 00
GROUP 08 EPC Assembly.....	0097 00
GROUP 09 EPC Poles.....	0098 00
GROUP 0901 Pin w/ Lanyard.....	0099 00
Special Tools List.....	0100 00
National Stock Number (NSN) Index.....	0101 00
Part Number (P/N) Index.....	0102 00
Components of End Item (COEI) and Basic Issue Items (BII) Lists.....	0103 00
Additional Authorized List (AAL).....	0104 00
Expendable and Durable Items List.....	0105 00

REAR MATTER

DA Form 2028-2: Recommended Changes to Equipment Technical Publications
Authentication Page
Metric Conversion Chart

HOW TO USE THIS MANUAL

This manual contains General Information, Operating Instructions, Preventive Maintenance Checks and Services (PMCS), and Maintenance/Repair Instructions for the Authorized Stockage List Mobility System (ASLMS).

Front matter consists of front cover, warning summary, title block, table of contents, "how to use this manual" pages, and provides introductory information on the ASLMS and its associated equipment. Chapter 1 provides equipment description and data as well as the theory of operation. Chapter 2 provides instructions for operating under usual and unusual conditions. Chapter 3 contains troubleshooting procedures authorized at the Operator and Unit level. Chapter 4 contains Preventive Maintenance Checks and Services (PMCS) and Operator Maintenance Instructions. Chapter 5 contains Unit Maintenance Instructions. Chapter 6 contains Direct Support Maintenance instructions. Chapter 7 contains the Maintenance Allocation Chart (MAC); it also includes the Repair Parts & Special Tools List (RPSTL) that identifies parts or tools unique to the operation and maintenance of the ASLMS. Rear matter consists of the DA Form 2028, an authentication page, and back cover.

Manual Organization and Page Numbering

This manual is divided into seven major chapters that detail the topics mentioned above. Within each chapter are work packages covering a wide range of topics. Each work package is numbered sequentially at page 1, and has its own page numbering scheme that is independent of the page numbering used by other work packages. Each page of a work package has a page number of the form "XXX YY-ZZ", where "XXXX YY" is the work package number (e.g. 0010 00 is work package 10) and "ZZ" represents the number of the page within that work package. A page number such as "0010 00-1/2 Blank" means that page 1 of that work package contains information but page 2 has been intentionally left blank.

Finding Information

The Table of Contents permits the reader to quickly find information in the manual. The reader should start here first when looking for a specific topic. The Table of Contents lists the topics contained within each chapter and the work package sequence number where it can be found.

Types of Notations

Warnings - Warnings are posted immediately prior to text covering any area that would present a situation that may result in injury or death. Compliance is mandatory.

Cautions - Cautions will be found on the same page and preceding the text covering any area that would present a situation that may result in damage to equipment.

Notes - Notes will precede text covering an area with the intent to alter normal procedures for unique situations or equipment, or point out areas of special concern.

CHAPTER 1
DESCRIPTION AND THEORY OF OPERATION

OPERATOR'S, UNIT AND DIRECT SUPPORT MAINTENANCE**AUTHORIZED STOCKAGE LIST MOBILITY SYSTEM (ASLMS)**

**MODEL NUMBER FPU-8/12 PARTS (OD) P/N 15005002-001
NSN 5411-01-523-2071**

**MODEL NUMBER FPU-8/12 PARTS (DS) P/N 15005002-002
NSN 5411-01-523-2072**

**MODEL NUMBER FPU-8/12 BULK (OD) P/N 15005001-001
NSN 5411-01-523-2073**

**MODEL NUMBER FPU-8/12 BULK (DS) P/N 15005001-002
NSN 5411-01-523-2074**

GENERAL INFORMATION

SCOPE**Equipment Covered**

This technical manual contains instructions for the operation, preventive maintenance, Unit and Direct Support corrective maintenance for the Authorized Stockage List Mobility System (ASLMS) and its associated equipment.

Type of Manual

This is an Operator's, Unit and Direct Support, Operation and Maintenance Manual, including Repair Parts & Special Tools List.

Equipment Name and Model Number

Authorized Stockage List Mobility System (ASLMS)

**MODEL NUMBER FPU-8/12 PARTS (OD) P/N 15005002-001
NSN 5411-01-523-2071**

**MODEL NUMBER FPU-8/12 PARTS (DS) P/N 15005002-002
NSN 5411-01-523-2072**

**MODEL NUMBER FPU-8/12 BULK (OD) P/N 15005001-001
NSN 5411-01-523-2073**

**MODEL NUMBER FPU-8/12 BULK (DS) P/N 15005001-002
NSN 5411-01-523-2074**

Purpose of Equipment

The ASLMS consists of modular containers with bin, pallet, security basket, and bulk storage configurations tailored to meet individual Supply/Maintenance/ Logistical Support needs. The system has the ability to operate in fixed facilities or field environments in either its uploaded or downloaded configuration. Containers are air-deployable and linkable into variable length sections. The ASLMS provides containerized Class IX ASL storage with full strategic/tactical intermodal transportability for supply support activities.

MAINTENANCE FORMS, RECORDS, AND REPORTS

Department of the Army forms and procedures used for equipment maintenance will be those prescribed by (as applicable) DA PAM 738-750, Functional Users Manual for the Army Maintenance Management System (TAMMS); DA PAM 738-751, Functional Users Manual for the Army Maintenance Management Systems - Aviation (TAMMS-A); or AR 700-138, Army Logistics Readiness and Sustainability.

REPORTING EQUIPMENT IMPROVEMENT RECOMMENDATIONS (EIR)

If your ASLMS needs improvement, let us know. Send us an EIR. You, the user, are the only one who can tell us what you don't like about your equipment. Let us know why you don't like the design or performance. Put it on an SF 368 (Product Quality Deficiency Report). Mail it to Commander, U.S. Army Tank-automotive and Armament Command, ATTN: AMSTA-LC-R, Kansas Street, Natick, MA 1760-5052. We will send you a reply.

CORROSION PREVENTION AND CONTROL (CPC)

Corrosion Prevention and Control (CPC) of Army materiel is a continuing concern. It is important that any corrosion problem with the ASLMS be reported so that the problem can be corrected and improvements can be made to prevent the problem in the future items.

While corrosion is typically associated with rusting of metals, it can also include deterioration of other materiel, such as rubber and plastic. Unusual cracking, softening, swelling, or breaking of this materiel may be a corrosion problem.

If a corrosion problem is identified, it can be reported using Standard Form 368, Product Quality Deficiency Report. Use of key words such as "corrosion," "rust," "deterioration," or "cracking" will ensure that the information is identified as a CPC problem.

The form should be submitted to the address specified in DA PAM 738-750, Functional Users Manual for the Army Maintenance Management System (TAMMS).

OZONE DEPLETING SUBSTANCES (ODS)

The continued use of ODS has been prohibited by Executive Order 12856 of 3 August 1993. The use of ODS in Army IETM is prohibited. A listing of these substances will be provided by the acquiring activity.

DESTRUCTION OF ARMY MATERIEL TO PREVENT ENEMY USE

Procedures for destruction of Army materiel to prevent enemy use can be found in TM 750-244-6.

PREPARATION FOR STORAGE OR SHIPMENT

All preventive maintenance checks and services should be performed on the ASLMS and its components prior to any storage or shipment.

RECEIVING THE ASLMS INVENTORY**Unpacking and Inventory of ASLMS Components upon Initial Receipt**

With the ASLMS containers downloaded, check the equipment against the Components of End Item List and Basic Issue List. Report any discrepancy to your supervisor.

END OF WORK PACKAGE

FPU-8/12 Container Configurations

When configured for parts, the container has an FPU-8 container with four short/modules. Each module consists of one 8-inch drawer, three 6-inch drawers, one 4-inch drawer and a basket mounted on top. It is linked with an FPU-12 container that is configured with sixteen 12-inch medium drawers, four 2-inch medium drawers, two 8-inch small drawers, and two 2-inch small drawers. The 12-inch drawers have adjustable dividers. The 8-inch and 2-inch drawers are provided with cargo nets to secure material.

When the FPU 8/12 is configured for bulk, the FPU-8 container has four large pallets with two 60-inch ratchet straps to secure material. Additionally, it is linked with an FPU-12 that is configured with six medium pallets, two medium HAZMAT pallets, three small pallets and one small HAZMAT pallet. Each HAZMAT pallet is equipped with a cargo net to secure material. The HAZMAT pallets are eight inches deep and lined with a corrosion resistant material to act as secondary containment for stored materials.

LOCATION AND DESCRIPTION OF MAJOR COMPONENTS**FPU-8/12 Container**

The Field Pack-Up Unit (FPU) when joined in a twenty-foot configuration is capable of transport via the HEMTT utilizing the built in bail bar and attachable rear rollers. Each 20-foot container consists of an eight and twelve foot container in either a parts or bulk configuration.

FPU-8 Container

The FPU-8 series container is available in both parts and bulk configurations: The parts configuration utilizes two floor adapter plates (FAP) to lock down four modules; the bulk configuration utilizes stowage racks to hold four pallets. The FPU-8 series containers are designed to be transported by standard material handling equipment (MHE), palletized loading systems, various load handling systems, standard transportation systems, and dolly set-mobilizer systems. The tubular steel construction with ISO corner blocks enables them to be stacked or sling-loaded. FPU-8 series containers accommodate a full range of storage / shipping modules and bulk pallets.

FPU-12 Container

The FPU-12 has four bi-fold doors each side and a 12-pallet rack system. This system offers a wide range of use from large and bulky material to small and medium items. The FPU-12 and FPU-8 series combine to form a 20-foot system using the horizontal interconnectors.

Adjustable Pallets and Drawers

The ASLMS is designed to store and ship bulk material as well as small parts. Pallets come in small, medium and large sizes. All pallets come with two-inch ratchet straps or cargo netting. Drawers consist of 2-inch, 8-inch and 12-inch deep varieties in small or medium widths. The HAZMAT pallets are eight inches deep and lined with a corrosion resistant material to act as secondary containment for stored material. Each pallet or drawer height is user adjustable in 4-inch increments; appropriate MHE should be used for making any adjustments.

Short/Module

Features a five-drawer lower half consisting of one 4-inch, three 6-inch and one 8-inch drawer with an upper half removable stand-alone basket. The basket includes split adjustable shelves and a two-stage, opening door. The module is designed for "3G" force conditions.

Electrical System

The electrical system is provided power through two 150-foot cables with Power Distribution and Illumination System, Electrical (PDISE) compatible connections. When connected to a PDISE this system provides three 120 VAC single-phase, 20 amp rated Ground Fault Circuit Interrupter (GFCI) outlets and a step down transformer for converting 120 VAC to 12 VDC for four low voltage overhead lighting fixtures, for personnel safety. The red/white interior lights provide light discipline capability. These lights allow operators access to storage locations during limited visibility with a minimum illumination of five-foot candlepower. Lighting fixtures are stowed inside overhead compartments and accessed as discussed in WP 0008 00.

Ventilation Devices

A closeable, solid-matter-filtered, free-air-exchange ventilation device provides fresh air and ensures pressure equalization when the container is moved via aircraft. A user-activated ventilation device door and drainage holes secures the container's interior in the event of exterior contamination. Inside the right door (far right in FPU-12 and FPU-8) near the upper hinges are two pull handles. One handle is to raise the ventilation device door and the other to release it. The ventilation device door should be in the raised position during normal operations.

The ventilation device should be in the closed position when advised of an imminent biological/chemical attack or during adverse weather conditions. This will protect the inside material from becoming contaminated.

ASLMS ACCESSORIES**Element Protective Cover (EPC)**

The EPC is designed to protect personnel and repair parts stored within parts and bulk storage containers from environmental conditions. It also serves as a barrier for light during blackout operations (refer to WP 0009 00 for additional information).

Floor Adapter Plate (FAP)

FPU-8 Parts containers are equipped with two module floor adapter plates. Each module adapter plate holds two short modules.

Fork Pocket Adapter Plug

Designed to fit into the opening of the FPU-8 forklift pocket, the fork pocket adapter plug allows the container to be locked down onto the M1076 PLS trailer during rail transport. The connectors are stowed inside the ASLMS and inserted only when the ASLMS container is loaded on the M1076 PLS trailer and is being transported by train (refer to WP 0005 00 for additional information).

Rear Rollers

The rear rollers are detachable dual seven inch rollers mounted at the rear under the FPU-8 container using two 3/4-inch pins. Once connected to the FPU-8/12, it allows the 20-foot configuration to be loaded/unloaded on the HEMTT truck and M1076 PLS trailer using the bail bar and integrated loading rails. The rear rollers are stored in the ASLMS FPU-12 when not in use. For storage, removal, and installation of the rear rollers, refer to WP 0005 00.

Horizontal Interconnectors and Bridge Locks

Four horizontal interconnectors are used to connect the FPU-8 and FPU-12 for use when operating the system as a linked 20-foot container. The container connecting devices allows the containers to be stacked or transported using ISO container transportation devices. These connectors must be installed in accordance with procedures described in WP 0005 00. Additionally, for added strength and system integrity, two bridge locks are stored in each FPU and must be installed on the rooftop ISO Blocks. These bridge locks will not be used during maritime shipment of ASLMS.

Loading Rail Connector Assembly

A loading rail connector assembly is also provided for connecting FPU-8 and FPU-12 containers. This assembly is stored with other connector kit items in the FPU-12 container (refer to WP 0005 00 for additional information).

EQUIPMENT DATA

Length: 20-foot (6.1m)
 Width: 8-foot (2.44m)
 Height: 8-foot (2.44m)
 Weight Parts: See following chart
 Weight Bulk: See following chart

For Operations with HEMTT-LHS				
Container Type	Tare Weight	Max Gross Weight	Net (Cargo) Weight	MHE Recommended
ASLMS 20-Foot Bulk	14,300	26,000 (note)	11,700	HEMTT/RTCH
ASLMS 20-Foot Parts	19,160	26,000 (note)	6,840	HEMTT/RTCH
FPU-8 Bulk	4,820	18,000	13,180	20K Forklift
FPU-12 Bulk	9,480	19,000	9,520	20K Forklift
FPU-8 Parts	7,780	18,000	10,220	20K Forklift
FPU-12 Parts	11,380	19,000	7,620	20K Forklift
NOTE				
When operating ASLMS on a HEMTT, max gross weight loaded into FPUs must be calculated to comply with 26,000lb restriction.				

OPERATOR'S, UNIT AND DIRECT SUPPORT MAINTENANCE

AUTHORIZED STOCKAGE LIST MOBILITY SYSTEM (ASLMS)

**MODEL NUMBER FPU-8/12 PARTS (OD) P/N 15005002-001
NSN 5411-01-523-2071**

**MODEL NUMBER FPU-8/12 PARTS (DS) P/N 15005002-002
NSN 5411-01-523-2072**

**MODEL NUMBER FPU-8/12 BULK (OD) P/N 15005001-001
NSN 5411-01-523-2073**

**MODEL NUMBER FPU-8/12 BULK (DS) P/N 15005001-002
NSN 5411-01-523-2074**

EQUIPMENT DATA LABELS, IDENTIFICATIONS, MARKINGS AND AIRLIFT CERTIFICATION

ASLMS and CSC Data Plates

The ASLMS container data plates are affixed to the right-hand doors of each container, below the door handles. This plate identifies information required for transport aboard ship. The ABS data plate is located adjacent the ASLMS data plate. This plate identifies special requirements information for use during transport aboard ship.

APPROVED FOR TRANSPORT UNDER CUSTOMS SEAL		
USA/174-AB/03-01		
TYPE: FPU12-2	MFG No. OF CONTAINER AC001202-	
MANUFACTURER: ADVANCED CONTAINMENT SYSTEMS INC. 8720 LAMBRIGHT HEIKSTEN, TX 77075 TEL(713) 987-0336 FAX(713) 987-0355	APPROVED BY AMERICAN BUREAU OF SHIPPING AB/174/03	PATENT HOLDER/ DISTRIBUTOR: BOH INTERNATIONAL, INC. 730 SOUTH TONKI ST. NEW ORLEANS, LA. 70119 TEL(504) 621-2400
CSC SAFETY APPROVAL USA/AB-174/03-01		
DATE MANUFACTURED	IDENTIFICATION NUMBER USAU	REINSPECTION SHALL BE BEFORE
MAXIMUM GROSS WEIGHT	00000 KG 00000 LB	
ALLOWABLE STACK WT. FOR LBS	00000 KG 00000 LB	
RACKING TEST LOAD VALUE	00000 KG 00000 LB	

ASLMS DATA PLATE

THIS CSC APPROVAL IS VALID FOR ONE FPU 12-2 AND ONE FPU 8-3 COUPLED TOGETHER TO FORM A 20' X 8' X 8' CONTAINER USING TANDEMLOCK HORIZONTAL CONNECTORS (PART NO. 12900BA-1PZ) ONLY
--

**ABS SPECIAL REQUIREMENTS PLATE
CSC APPROVAL PLATE**



OPERATOR'S, UNIT AND DIRECT SUPPORT MAINTENANCE

AUTHORIZED STOCKAGE LIST MOBILITY SYSTEM (ASLMS)

**MODEL NUMBER FPU-8/12 PARTS (OD) P/N 15005002-001
NSN 5411-01-523-2071**

**MODEL NUMBER FPU-8/12 PARTS (DS) P/N 15005002-002
NSN 5411-01-523-2072**

**MODEL NUMBER FPU-8/12 BULK (OD) P/N 15005001-001
NSN 5411-01-523-2073**

**MODEL NUMBER FPU-8/12 BULK (DS) P/N 15005001-002
NSN 5411-01-523-2074**

EQUIPMENT DATA LABELS, IDENTIFICATIONS, MARKINGS AND AIRLIFT CERTIFICATION

ASLMS and CSC Data Plates

The ASLMS container data plates are affixed to the right-hand doors of each container, below the door handles. This plate identifies information required for transport aboard ship. The ABS data plate is located adjacent the ASLMS data plate. This plate identifies special requirements information for use during transport aboard ship.

APPROVED FOR TRANSPORT UNDER CUSTOMS SEAL

USA/174-AB/03-01

TYPE: FPU12-2 MFG No. OF CONTAINER: AC001202-

MANUFACTURER: ADVANCED CONTAINMENT SYSTEMS INC. 8720 LAMBRIGHT HEIKSTEN, TX 77075 TEL(713): 987-0336 FAX(713): 987-0355	APPROVED BY AMERICAN BUREAU OF SHIPPING AB/174/03	PATENT HOLDER/DISTRIBUTOR: BOH INTERNATIONAL, INC. 730 SOUTH TONDI ST. NEW ORLEANS, LA. 70119 TEL.(504) 621-2400
---	---	---

CSC SAFETY APPROVAL
USA/AB-174/03-01

DATE MANUFACTURED	REINSPECTION SHALL BE BEFORE
IDENTIFICATION NUMBER: USAU	
MAXIMUM GROSS WEIGHT: 00000 KG 00000 LB	
ALLOWABLE STACK WT. FOR LBS: 00000 KG 00000 LB	
RACKING TEST LOAD VALUE: 00000 KG 00000 LB	

ASLMS DATA PLATE

THIS CSC APPROVAL IS VALID FOR ONE

FPU 12-2 AND ONE FPU 8-3

COUPLED TOGETHER TO FORM A 20' X 8' X 8' CONTAINER USING TANDEMLOCK HORIZONTAL CONNECTORS (PART NO. 12900BA-1PZ) ONLY

**ABS SPECIAL REQUIREMENTS PLATE
CSC APPROVAL PLATE**



ASLMS is approved for transport as a combined 20-foot ISO container and also an FPU-8 or FPU-12 container. For their approval to be valid, the following requirements must be met:

1. Certified/tagged FPUs must be matched only. See the CSC approval plate on a certified FPU USA/174-AB/03-01 series container.
2. Individual FPUs must have a current CSC certification (shown on the CSC approval plate).

These certifications do not supercede military policies by Surface Deployment and Distribution Command (SDDC) in the shipment of serialized containers of matched sets.

All ASLMS containers are marked with the following ISO marking. It's meaning is provided below:



Contact with Overhead power lines and obstructions can cause serious injury, death, or damage to property. Forklift operators and truck drivers must use ground guides and always maintain clear overhead when loading, unloading or moving the ASLMS containers.

FPU Manufacturers Data Plate

FPU data plates identify the manufacturer's part number, serialization, contract and delivery order number and National Stock Number (NSN). They are located visibly at the exterior ends of each container. Each container has an FPU unique data plate.

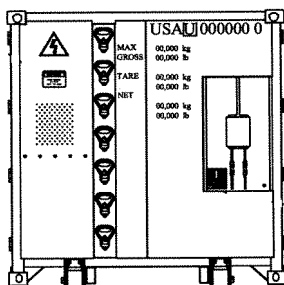

SIGNAGE FPU-8 END

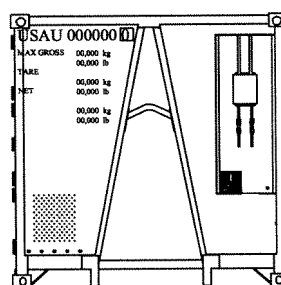

SIGNAGE FPU-12 END

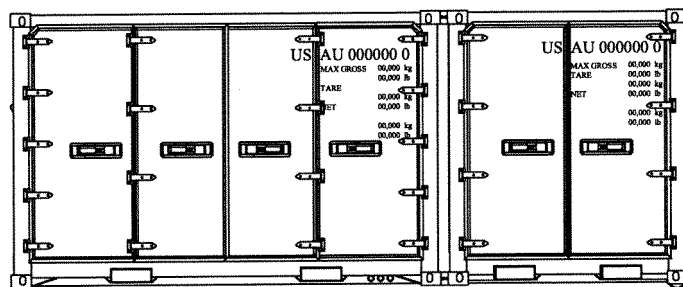

SIGNAGE FPU 8/12 FRONT AND BACK

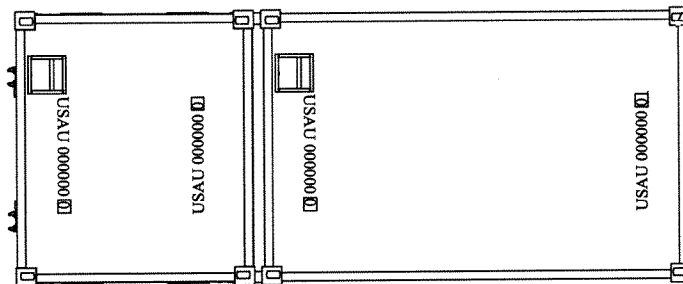

TOP VIEW OF SIGNAGE FPU 8/12

ASLMS containers have a series of markings that provide information and identification for shipping containers when transported aboard ships.

CAUTION

Do not remove, deface, or cover the information contained on labels, plates, and markings. Loss of this information will de-certify the container. It is recommended that ASLMS containers be maintained as sets by the CSC identification number (USAU number) found on the ends, sides and roof of each container.



AIRLIFT CERTIFICATION

The following letter describes the airlift certification relevant to the transportation of the ASLMS and its associated FPU containers.



DEPARTMENT OF THE AIR FORCE

HEADQUARTERS AERONAUTICAL SYSTEMS CENTER (AFMC)
WRIGHT-PATTERSON AIR FORCE BASE, OHIO

24 June 2004

MEMORANDUM FOR US ARMY MSDDC/TEA

MTTE-DPE (Jennifer Napiecek)
720 Thimble Shoals Blvd Suite 130
Newport News VA 23606-2574

FROM: ASC/ENFC (ATTLA)
2530 Loop Road West
Wright Patterson AFB, OH 45433-7101

SUBJECT: Air Transport Approval of the Authorized Stockage List Mobility System (ASLMS)

1. The ASLMS consists of two separate ISO containers that join together to form a standard military 8' x 8' x 20' unit. The smaller of the two containers is 8' x 8' x 8' and can be attached to the larger 8' x 8' x 12' unit with Tandem Lock interconnectors. The ASLMS is herein approved for airlift on USAF C-130, C-141, C-17, and C-5 aircraft with the following provisions:
 - a. The joined unit at 20' shall be palletized per standard procedures on a three-pallet train of HCU-6/E 463L pallets joined on the 108-inch sides. If separated, the smaller 8' container should be palletized on a single pallet and the larger 12' container should be palletized on a two-pallet train. For airlift on C-130 aircraft, the containers shall be offset to one side of the pallet base to provide an in-flight access aisle.
 - b. Alternatively, the separated ASLMS units may be loaded with an approved set of mobilizers, and lowered for flight onto shoring on the aircraft floor. The bottom of the ASLMS should not be placed in direct contact with the aircraft conveyor systems.
 - c. Shipping weight for the palletized 20' unit should not exceed 33,000 lbs. The individual units should not exceed 12,500 for the 8' container and 20,500 lbs for the 12' container.
 - d. Containers shall be secured to the pallet tie down rings or aircraft floor as necessary to achieve a minimum of 3 G forward & aft, 2 G up, and 1.5 G laterally using the ISO corner fittings and forklift pockets as hard points. When joined together with the Tandem Lock interconnectors, the 20' unit may be treated as one single item.
 - e. The shipper will certify that the contents of the containers as well as anything attached to the container structure will withstand the above forces in addition to a potential 4.5 G download
 - f. Any hazardous materials shall be prepared and packaged IAW AFMAN 24-204(I). This memo is not to be considered as approval to airlift hazardous materials, which must be granted separately through AFMC LSO/LOT. The servicing aerial port can assist in this regard.
2. POC is the undersigned at DSN 785-2330 or (937) 255-2330.

cc: HQ AMC/A37V
HQ AMC/A32
ASC/GRB

JAMES E. LEGER
Aerial Delivery Group

END OF WORK PACKAGE

OPERATOR'S, UNIT AND DIRECT SUPPORT MAINTENANCE**AUTHORIZED STOCKAGE LIST MOBILITY SYSTEM (ASLMS)**

**MODEL NUMBER FPU-8/12 PARTS (OD) P/N 15005002-001
NSN 5411-01-523-2071**

**MODEL NUMBER FPU-8/12 PARTS (DS) P/N 15005002-002
NSN 5411-01-523-2072**

**MODEL NUMBER FPU-8/12 BULK (OD) P/N 15005001-001
NSN 5411-01-523-2073**

**MODEL NUMBER FPU-8/12 BULK (DS) P/N 15005001-002
NSN 5411-01-523-2074**

THEORY OF OPERATION**THEORY OF OPERATION****ASLMS Containers - FPU 8/12, FPU-8 and FPU-12**

The ASLMS containers can operate independently when disconnected. They are designed to operate together as a mobile 20 ft. storage container system. The ASLMS system consists of two 20-foot long, 8-foot wide and 8-foot high storage containers (1 parts configuration and 1 bulk configuration), and is designed to make storing material easier and retrieving material quicker, while maintaining mobility. The containers are provided with storage aids, allowing the addition of pallets and/or drawers, depending on the configuration desired or individual parts. These storage/shipping modules have various size drawers with adjustable dividers. The electrical system is powered through two 150-foot cables connected to an M40 PDISE from the FPU-12. It provides three 120 VAC GFCI outlets and a step down transformer for converting 120 VAC to 12 VDC for four low voltage overhead lighting fixtures. Additional accessories such as rear rollers, EPC, floor adapter plate and a ventilation system allow the ASLMS containers to be transported using the HEMTT truck and to be operated during blackout conditions. The FPU-8/12 series containers also provide protection for stored material during biological and chemical attack as well as adverse weather conditions.

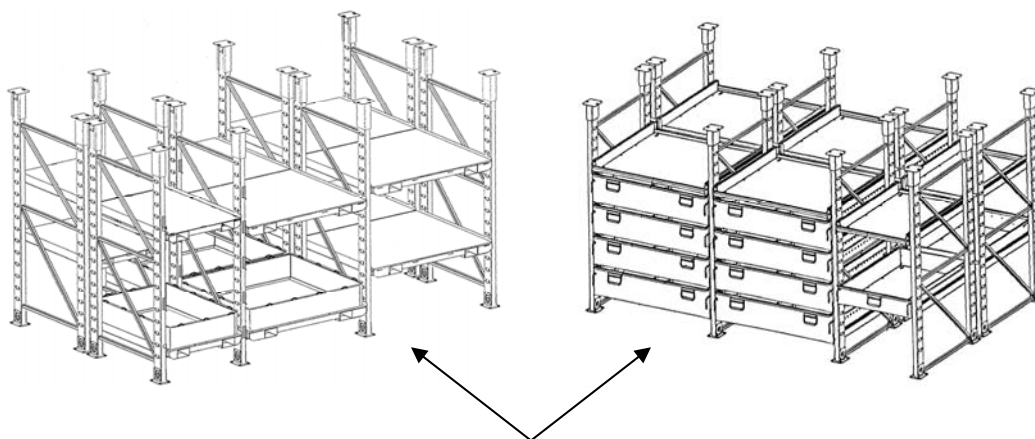
STORAGE AID RACK FRAMES FOR ADJUSTABLE PALLETS AND DRAWERS**STORAGE AID RACK FRAMES**

Storage aid rack frames support both bulk pallet and parts drawer ledges. Although the FPU 8/12-P and FPU 8/12-B are established as a parts or bulk container, they provide flexibility to mix an array of bulk pallets and parts drawers to tailor the needs for storage and shipment. The pallet ledges hold small, medium and large storage pallets with maximum capacity rating of 1000 lbs each and are equipped with 2-inch ratchet straps or nylon cargo netting to secure material.



WARNING

Some HAZMATs may react negatively with other HAZMATs. The MSDS for each type of hazardous material to be shipped must be referenced prior to shipment. All recommend chemical compatibility and safety procedures must be followed. Be sure to use the appropriate absorbent material inside the containers to absorb spills. All HAZMATs must be double wrapped prior to shipment in lined HAZMAT storage pallets. Failure to do so may result in a violent chemical reaction that could cause damage to pallets, ASLMS cargo, hardware and injury or death to personnel.

There are two 8-inch deep HAZMAT secondary containment pallets with a corrosion resistant liner and cargo net. There are sixteen 12-inch deep drawers, with adjustable dividers (adjustable in 2-inch increments from front to back), six 2-inch and two 8-inch drawers with nylon cargo netting to secure material. All drawers have a maximum capacity of 150 lbs.

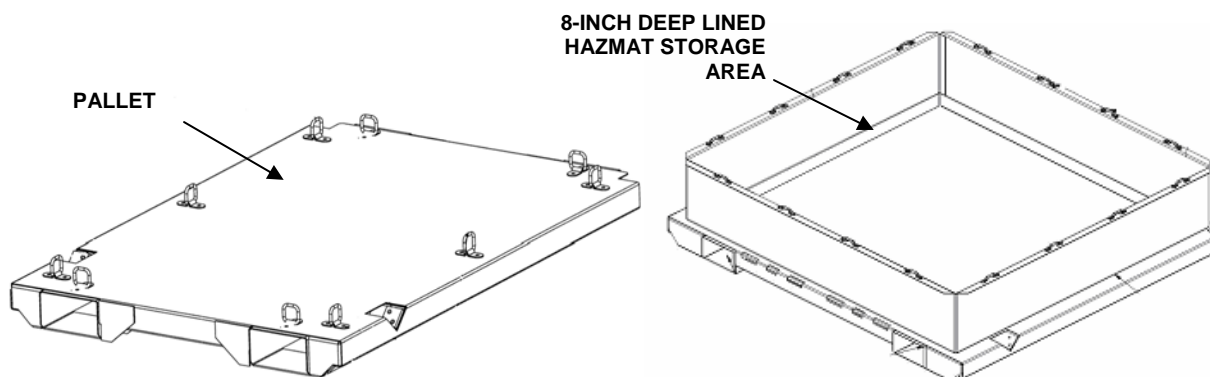

ASLMS Storage/Shipping Modules

The FPU-8 Parts unit is equipped with four storage/shipping modules. Each module consists of one 4-inch, three 6-inch, and one 8-inch deep drawer. The drawer compartments are provided with adjustable dividers (adjustable in 2-inch increments from front to back). Maximum drawer capacity is 150 lbs. Top basket has a bi-fold door and split adjustable shelves. All modules are designed to be interchangeable and therefore may be inserted into any of the ASLMS containers equipped with the floor adapter plate.

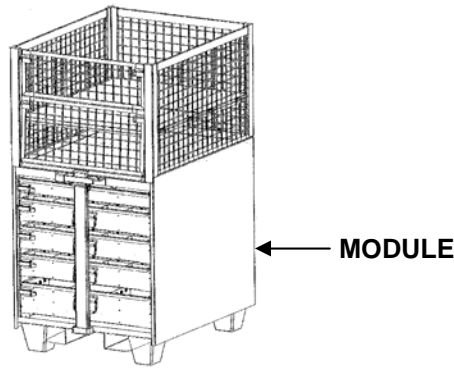

Electrical System

Two 150-foot power cables, each capable of supplying 20 AMP power from the PDISE to the first container connected in series. The quantity of containers in series is limited by current usage and voltage drop from container to container; therefore, it is not recommended that more than two ASLMS systems be connected in a series.

Each container has a power cable connection and a pass-through circuit to supply power to the next container connected in the series. The FPU-12 has a step down transformer to convert 120VAC to 12VDC, and self-coiling cables to supply power to the lighting in both the FPU-12 and the FPU-8 containers. Each cable and container panel has military-type, weather-tight pin-and-sleeve devices located at each end of each container to provide safe connections from container to container in the series. This prevents against disconnect interruptions and safeguards against mismatching connections of different amperages and voltage ratings. The inlet (male) and outlet (female) receptacles are compatible with plug ends on power cables so that a power cable can be used interchangeably with any container throughout the system. Plug-in connectors are located in recessed areas located at the ends of each container.

Cables must be manually connected and disconnected each time containers are relocated.

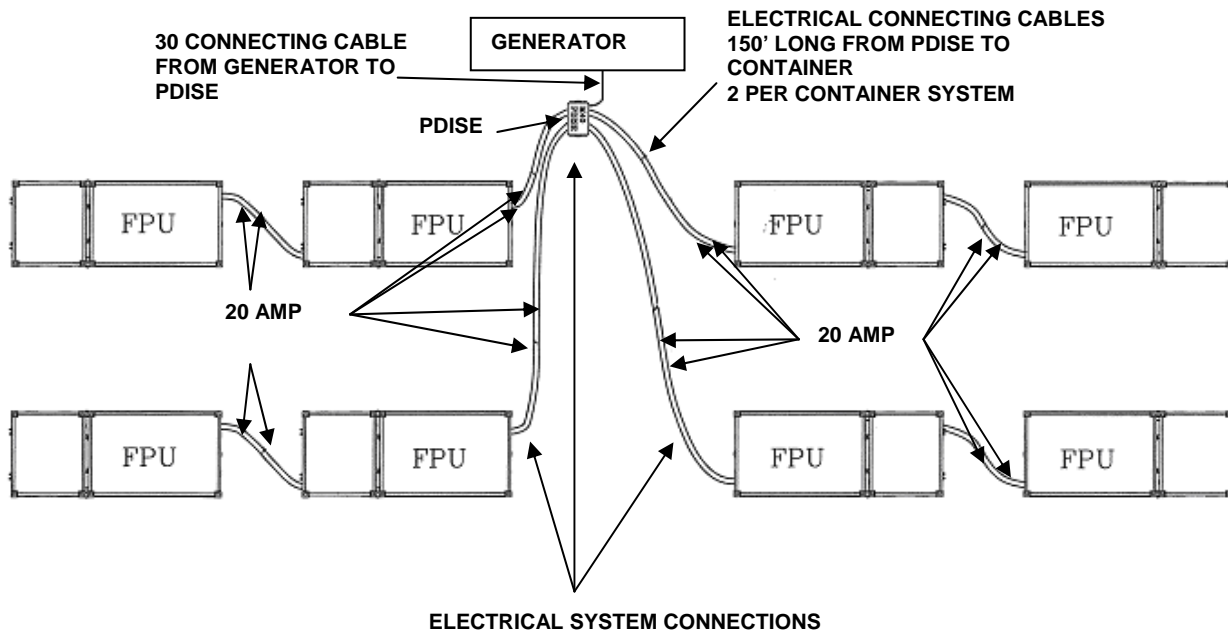

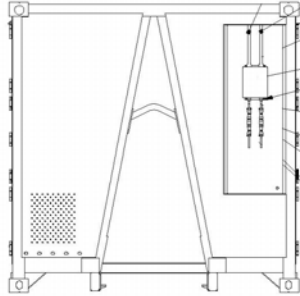

**FRONT FPU-12 ELECTRICAL A/C
ENTRANCE PANEL**

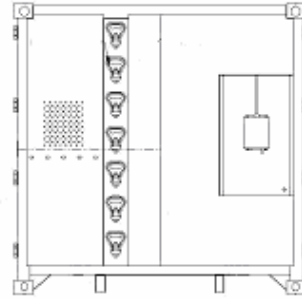

**REAR FPU-12 ELECTRICAL A/C AND D/C
EXIT PANEL**

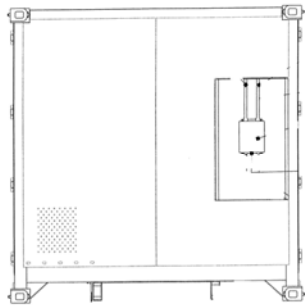

**FRONT FPU-8 ELECTRICAL A/C D/C
ENTRANCE PANEL**

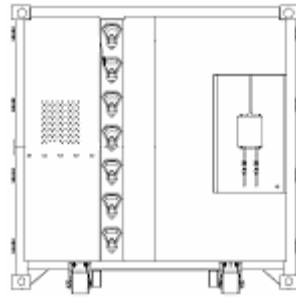

**REAR FPU-8 ELECTRICAL A/C
EXIT PANEL**



WARNING

Electrical power must be disconnected before any electrical system work is performed to prevent electric shock injury or death (electrocution). Only trained and qualified personnel (MOS 51R, 52C, 52D, OR 52G) may perform maintenance or attempt to correct electrical discrepancies on the electrical system.

Circuit breaker protection is provided in the circuit breaker panel of the M40 PDISE to serve as protection for receptacles and all other electrical devices connected to each individual container. Circuit grounding is provided through the three-conductor cable system back through the M40 PDISE. It is recommended that the ASLMS container be grounded to earth via an external grounding rod and strap (not furnished) connected to a grounding lug located at the power entrance of the FPU-12 and the exit panel of the FPU-8.

END OF WORK PACKAGE

CHAPTER 2
OPERATOR INSTRUCTIONS

OPERATOR'S, UNIT, AND DIRECT SUPPORT MAINTENANCE

AUTHORIZED STOCKAGE LIST MOBILITY SYSTEM (ASLMS)

**MODEL NUMBER FPU-8/12 PARTS (OD) P/N 15005002-001
NSN 5411-01-523-2071**

**MODEL NUMBER FPU-8/12 PARTS (DS) P/N 15005002-002
NSN 5411-01-523-2072**

**MODEL NUMBER FPU-8/12 BULK (OD) P/N 15005001-001
NSN 5411-01-523-2073**

**MODEL NUMBER FPU-8/12 BULK (DS) P/N 15005001-002
NSN 5411-01-523-2074**

PREPARATION FOR MOVEMENT

INITIAL SETUP:

Equipment Condition
ASLMS packed out.

Maintenance Level
Operator/Crew

Personnel Required
Four (plus one HEMTT or MHE driver).

PREPARATION FOR MOVEMENT



WARNING

During transit movement of any kind or if the container is dropped, contents may have shifted and extreme care should be taken when opening the doors to preclude material from falling on and injuring personnel.

When the ASLMS is received, all equipment necessary for setup and operation is packed inside the container. This work package provides step-by-step instructions for the download, set-up and moving of the ASLMS containers.

Site Requirements



WARNING

Container must be operated on level ground be periodically checked for shifting from a level position. Use care when opening doors or drawers, as physical injury may occur. To maintain control, consider ground surface conditions that may not provide adequate traction, such as mud, snow, ice, sand.

1. If the container is transported on the HEMTT-LHS truck or M1076 PLS trailer, the selected site must have a minimum of 50 ft x 30 ft of flat, level, open space to provide setup space for the container. This site must also allow space for the overhead cover that provides protection from the elements

2. while using the ASLMS. Care should be taken to ensure that no overhead obstructions interfere with the offload of the container from the HEMTT.

CAUTION

Flood plain conditions should be considered since the containers have vent holes for the ventilation system that are not designed to withstand flooding. If in doubt, consult the operations supervisor or commander.

CAUTION

When external electrical power is used, the ASLMS must be positioned within 150 feet of the PDISE. Never attempt to connect any power source directly to the containers without going through the PDISE panel. The connecting power cables should be routed away from personnel and vehicular traffic paths. Cables routed toward areas of personnel movement or across a road or other potential vehicle path, must be protected from damage.

PREPARING ASLMS FOR USE

The ASLMS is designed for a ground-based operation. Never attempt to access the containers when the containers are on any transporting equipment, or not downloaded and established in an operational site. Once downloaded from the HEMTT truck or M1076 PLS trailer, the ASLMS is ready for immediate use in most circumstances. Opening the doors allows users to access stored material and all equipment required to assemble the EPC. The EPC provides the users with protection from the elements. Power cables allow connection to an electrical power source for operation of organizational equipment, and red lights are required for operations during blackout conditions. If FPU-8 and FPU-12 containers are delivered separately, the containers must be connected before loading on the HEMTT vehicle.

OPERATION OF ROOF ACCESS SYSTEM



WARNING

Fall hazards that may cause injury or death exist when climbing onto, returning from or working from the top of the container. Always maintain three points of contact (two feet and one hand, or one hand and two feet) with the folding steps and roof access handle when climbing onto the ASLMS container. All movement should be in the forward direction. Never move, step, or walk backward when working on top of the system. A fall can occur if a worker loses concentration and steps backward off the edge. Stand erect only if necessary, and only away from the edge. Working from a kneeling position helps reduce the threat of a fall. Access to roof by forklift or other MHE is forbidden.

The roof access system consists of seven retractable fold-down steps, on the ends of the FPU-12 and the FPU-8, with handles recessed in the roof for three point control while climbing. Access to the roof is required during EPC deployment, and while striking or disconnecting and connecting the containers.

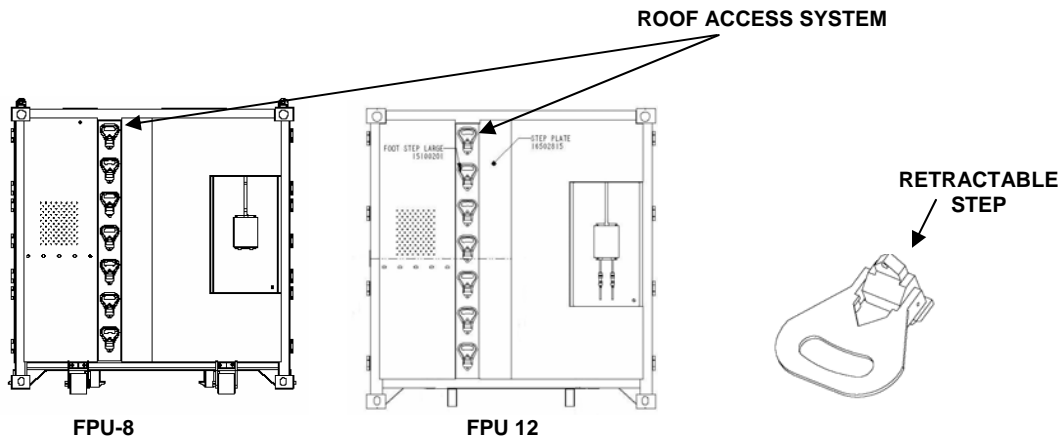
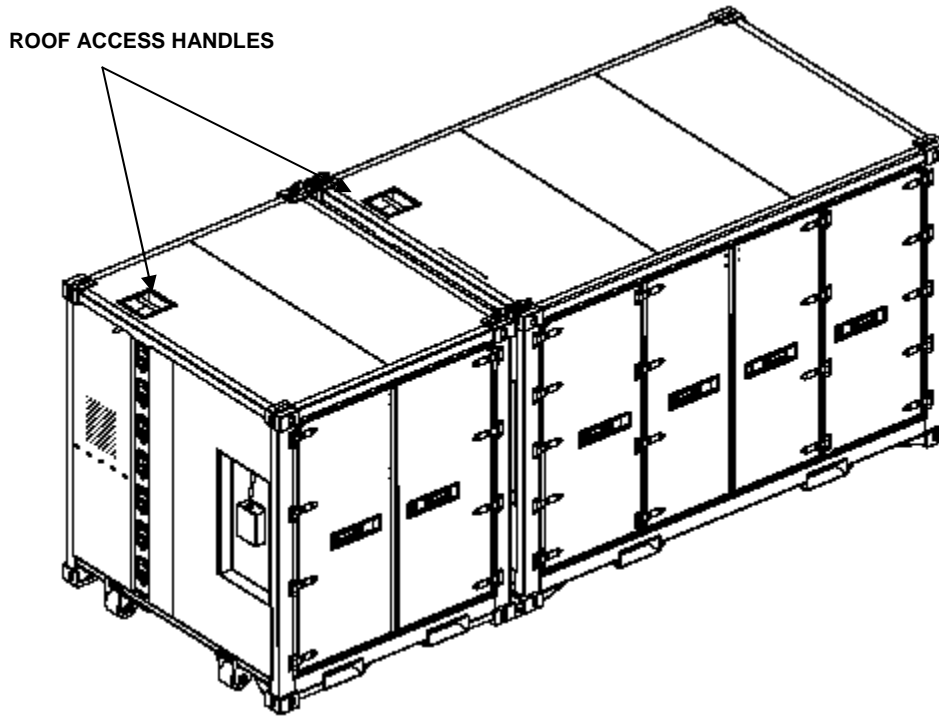

DISCONNECTING FPU-8 AND FPU-12 CONTAINERS

NOTE

Four people, plus the MHE or HEMTT driver, are required to perform this task. All tools identified in the following processes are Basic Issue Items (BII) and are listed in Chapter 7 of this manual or are in the GMTK.

1. Select a firm, level road surface to disconnect the containers.

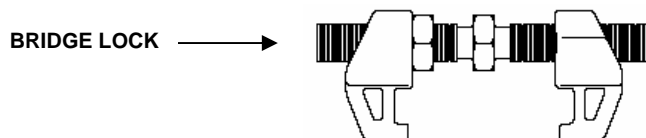

2. Return to the roof via the roof access system located on the roller end of the FPU-8 to remove the bridge lock connectors as follows.
 - a. In kneeling position, turn bridge lock jam nut away from closest jaw to loosen.
 - b. Loosen jaws using the 2 1/8-inch structural wrench by turning the adjuster nut away from the operator.

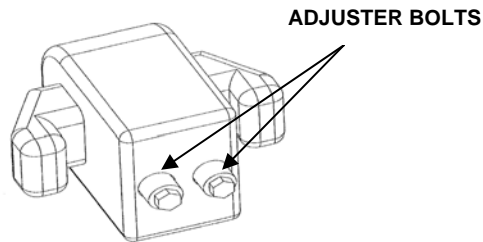

3. Retract fully the adjuster nuts on the two top horizontal interconnectors (FPU-8 side).
4. Return to ground via roof access system at the end of the FPU-8.
5. Using 1½-inch open-end wrench loosen jam nut on the transverse stabilizer tensioning blocks.

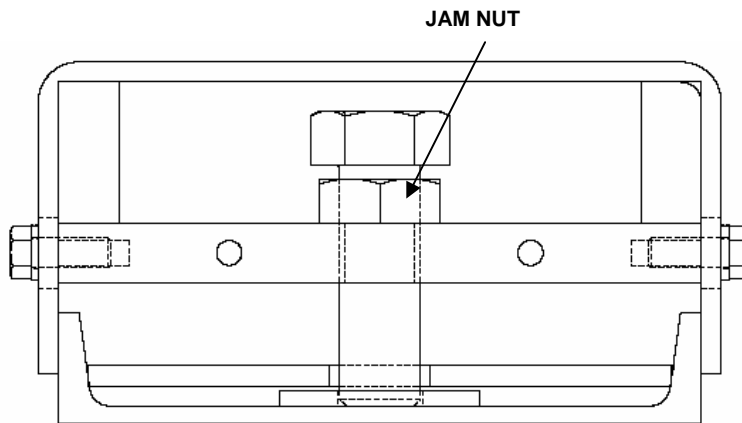

6. Fully retract adjuster bolt on transverse stabilizer block.
7. Fully retract adjuster nuts on the two lower horizontal interconnectors (FPU-8 side).
8. If using a HEMTT, attach the loading hook to the bail bar on FPU-12. Ensure the HEMTT is in a straight line with the container to prevent cocking.

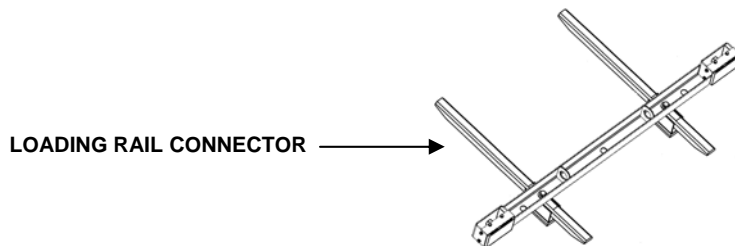

9. Lift slightly until front end is approximately 1-inch off the ground, and pull forward until the loading rail connector is completely clear of the loading rails of both containers. Containers are at least 4-feet apart.
10. Lower and disconnect from HEMTT.

NOTE

The transverse stabilizer may bind at this point and could prevent the containers from coming apart. If this happens the operator will have to push the containers back together and retry pulling them apart until successful. Hint: You can assist this operation by using a 2 X 4 board, or equivalent, to pry open the sticking side of the transverse stabilizer.

11. If using a forklift or other vehicle as listed in the table in this work package to disconnect the FPU-8 from the FPU-12, attach a properly-rated chain from the towing vehicle to both bottom ISO blocks on the FPU-8.
12. Ensure the towing vehicle is in a straight line with the container and that chain spacing is equal on both sides, to prevent cocking.
13. Slowly pull forward until containers are separated and the loading rail adapters are completely clear of the loading rails of both containers (containers are at least 4-feet apart).
14. Using the 1 1/8-inch socket, 1/2-inch drive flex head wrench and 2 1/2-inch long extension, disconnect the transversal stabilizer cross bar from the loading rail connectors.
15. Return to the roof via the roof access system located on the roller end of the FPU-12 to remove the upper horizontal interconnectors.
16. While supporting the horizontal interconnectors, completely retract adjuster nuts on the two upper horizontal interconnectors (FPU-12 side) and remove. Store in a secure place.
17. Return to ground via roof access system at the end of the FPU-12.
18. Completely retract adjuster nuts on the two lower horizontal interconnectors (FPU-12 side) and remove and store in a secure place.
19. Disconnect the AC and DC power cables from between both containers and store in a secure place.
20. Using suitable MHE, raise end of the container, while retaining loading rail connectors slightly off the ground (approximately 1-inch).
21. Slide both of the loading rail connectors from the loading rails. Store in a secure place.

CONNECTING ASLMS CONTAINERS

CAUTION

Bridge lock connectors are used in conjunction with ISO horizontal interconnectors for loading and transportation, but must be removed when stacking, or for maritime shipping, to meet ISO certification standards.

ASLMS FPU-8 and FPU-12 containers are connected using four horizontal interconnectors on the ISO corner blocks of each container, two bridge lock connectors at the top of the ISO blocks, and the one loading rail connector between the containers.

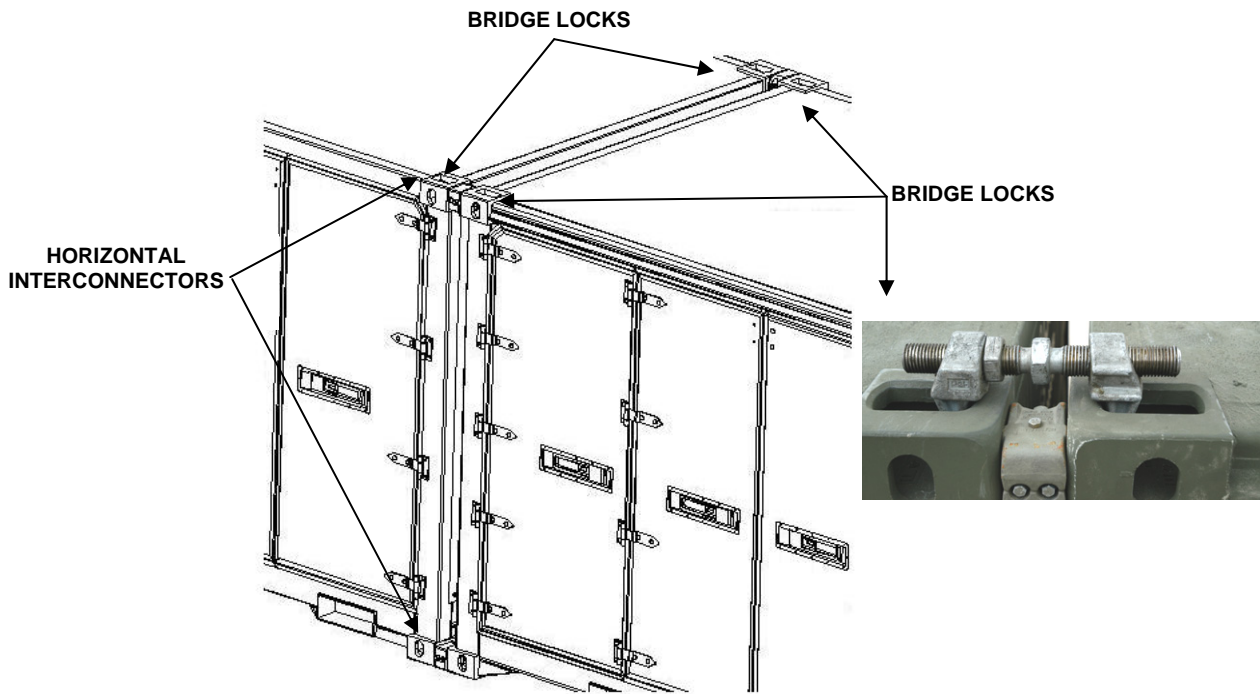
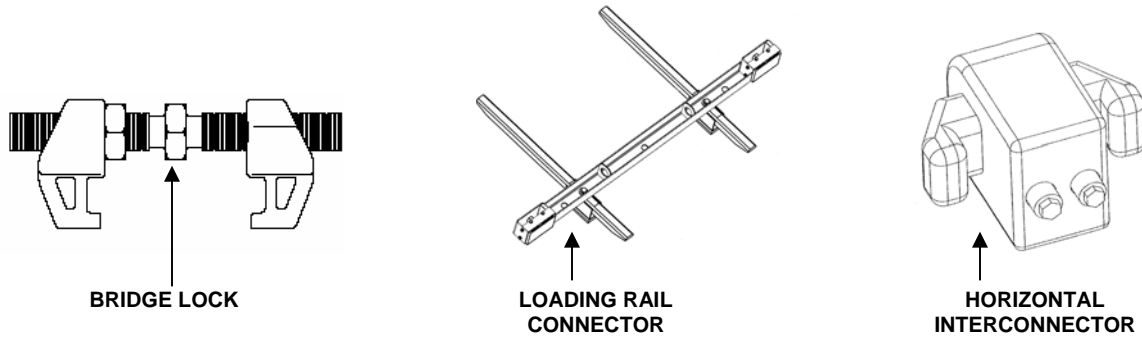

MOVING THE ASLMS USING MHE (FORKLIFT)

The FPU-8 and FPU-12 containers are designed with forklift pockets located on their sides. When the two containers are connected together the two inside forklift pockets are used.

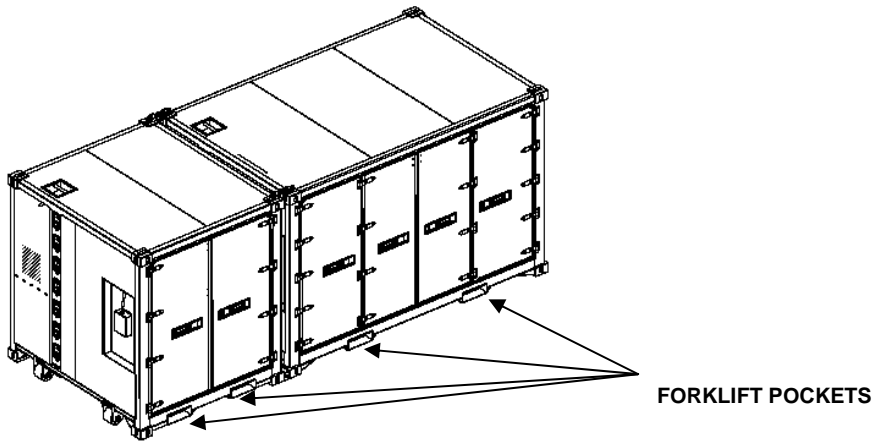
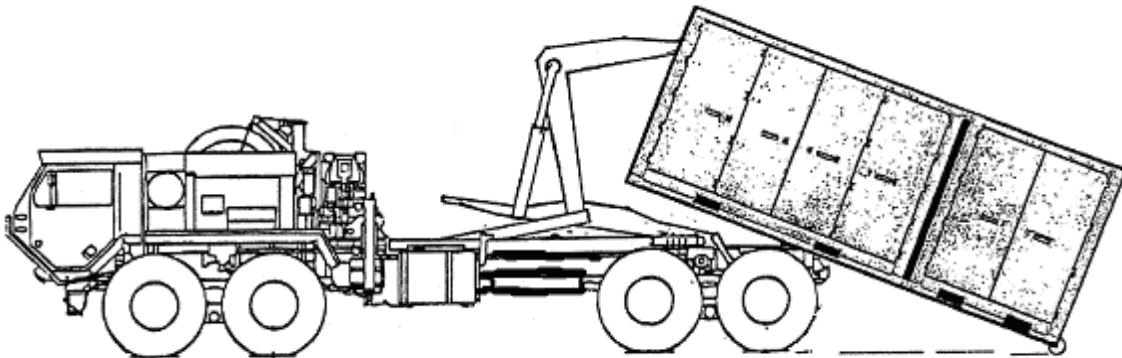
**LOADING THE ASLMS USING A HEMTT**

Loading and unloading via the HEMTT-LHS must be accomplished as indicated in HEMTT-LHS technical manual. Loading and unloading onto and off of a M1076 Palletized Load-handling System Trailer (PLST) must be accomplished as indicated in the PLS technical manual (TM 9-2320-364-10).

CAUTION

Do not exceed 26,000 lbs. Maximum gross weight (MGW) for loading ASLMS aboard HEMTT transport. Refer to the weight chart below.

For Operations with HEMTT-LHS				
Container Type	Tare Weight	Max Gross Weight	Net (Cargo) Weight	MHE Recommended
ASLMS 20-Foot Bulk	14,300	26,000 (note)	11,700	HEMTT/RTCH
ASLMS 20-Foot Parts	19,160	26,000 (note)	6,840	HEMTT/RTCH
FPU-8 Bulk	4,820	18,000	13,180	20K Forklift
FPU-12 Bulk	9,480	19,000	9,520	20K Forklift
FPU-8 Parts	7,780	18,000	10,220	20K Forklift
FPU-12 Parts	11,380	19,000	7,620	20K Forklift
NOTE				
When operating ASLMS on a HEMTT, Max Gross Weight loaded into FPUs must be calculated to comply with 26,000 lb restriction.				

CAUTION

Caution must be exercised when transporting the ASLMS on the M1076 PLS trailer on cross-country terrain that can produce excessive vibration and shock. When conditions simulate the 6-inch washboard effect, damage may result to the ASLMS container and the material stored within, when driving at excessive speed for this condition. Operators should always adjust driving speed to local conditions for safe operation. If a 6-inch washboard effect is encountered, it may be necessary to reduce speed to as low as 3 miles per hour to avoid damaging the ASLMS and its contents.

INSTALLING THE LOADING RAIL CONNECTOR ASSEMBLY & HORIZONTAL INTERCONNECTORS BETWEEN FPU-8 AND FPU-12 CONTAINERS

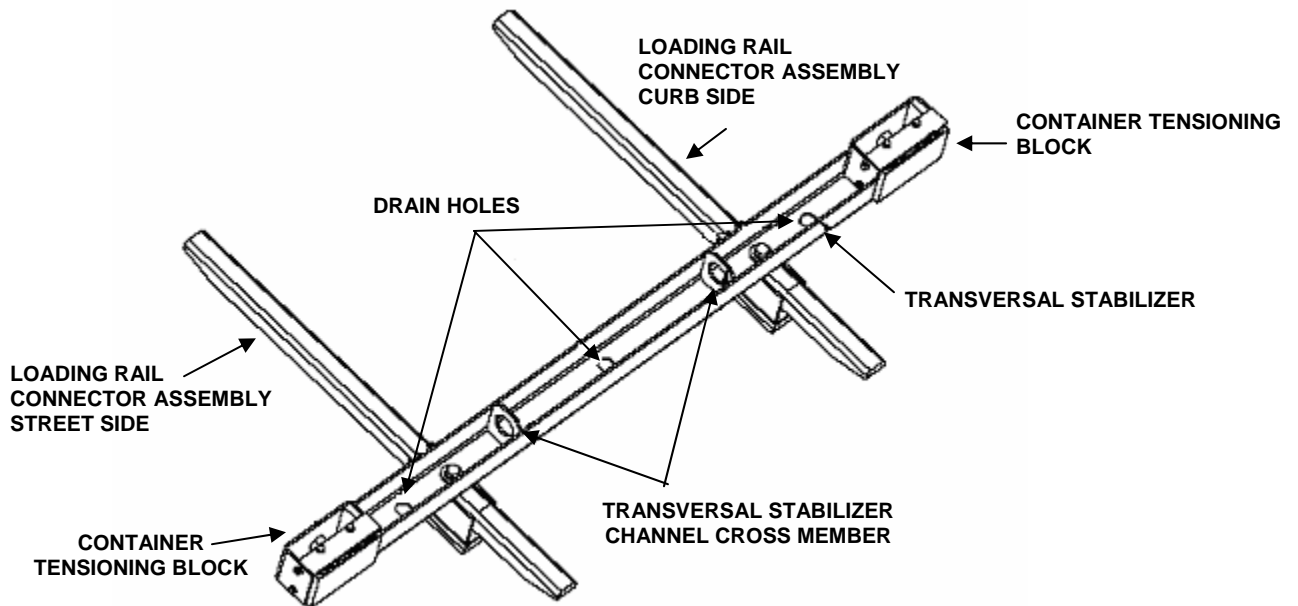

WARNING

Work with two ground guides when connecting individual containers in a combination system. Never move the FPU container while the ground guide is between the MHE fork and the FPU container. Forklift operators must maintain visual contact with their ground guides at all time. Serious injury or death could occur if the ground guide is pinned between the MHE and the FPU container.

NOTE

All tools identified in the following processes are Basic Issue Items (BI).

1. Select only a firm level road surface to connect the containers. Align the container ends to be connected. Leave about four feet between the containers to allow working space for attaching the container connectors.
2. Horizontal interconnectors should have both arms extended in the open position and the adjuster screws positioned inboard toward each other to prevent their damage.

**WARNING**

Fall hazards that may cause injury or death exist when climbing onto, returning from or working from the top of the container. Always maintain three points of contact (two feet and one hand, or one hand and two feet) with the folding steps and roof access handle when climbing onto the ASLMS container. All movement should be in the forward direction. Never move, step, or walk backward when working on top of the system. A fall can occur if a worker loses concentration and steps backward off the edge. Stand erect only if necessary, and only away from the edge. Working from a kneeling position helps reduce the threat of a fall. Access to roof by forklift or other MHE is forbidden.

3. To install the upper horizontal interconnectors, access the roof via the roof access system in the end of the FPU-12.
4. Insert horizontal interconnectors in the two top ISO corner block openings of the FPU-12 container.
5. While holding the horizontal interconnector in place, tighten the bolt in the interconnector body closest to the FPU-12 until seated firmly using a 9/16-inch hex socket, 2 ½-inch long extension and ½-inch square drive flex head wrench. The bolt will be recessed and flush with the connector housing when complete.

**WARNING**

Make sure all container connectors are properly seated and secured. Failure to comply could cause serious injury, death, or property damage.

6. After the two upper horizontal interconnectors are secured in place climb from the roof via roof access system.
7. Insert horizontal interconnectors into the two lower ISO corner block openings in the FPU-12 container.
8. While holding the horizontal interconnector in place, tighten the bolt in the interconnector body closest to the FPU-12 until seated firmly using a 9/16-inch hex socket, 2½-inch long extension and ½-inch square drive flex head wrench. The bolt will be recessed and flush with the connector housing when complete.



WARNING

Make sure all container connectors are properly seated and secured. Failure to comply could cause serious injury, death, or property damage.

9. Insert the long end of the loading rail connectors into the open ends of the loading rails on the FPU-12. Fully insert until they are firmly seated with the load rail blocks contacting the ends of the loading rails and just under the edge of the FPU-12 container.

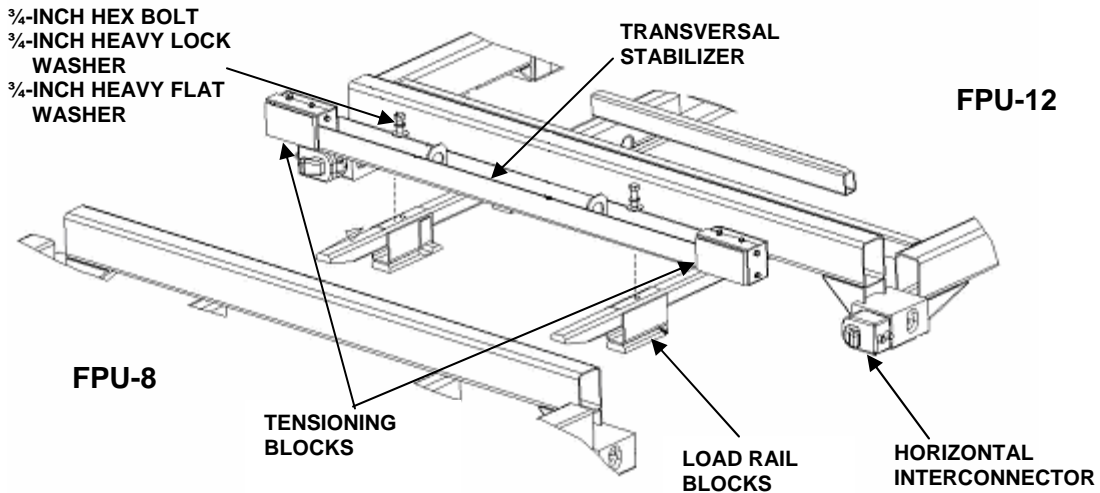

CAUTION

Check loading rail assembly connection areas to be sure they are free of debris before mating assembly pieces.

10. Install the transversal stabilizer crossbar onto the load rail connectors. Using the 1 1/8-inch socket, 1/2-inch drive flex head wrench and 2 1/2-inch long extension tighten the 3/4-inch bolts (with flat washer closest to stabilizer and lock washer above insert the 3/4-inch bolts and tighten firmly).
11. Ensure the two expandable end-tensioning blocks are fully retracted by adjusting tensioning block bolts and jam nuts.

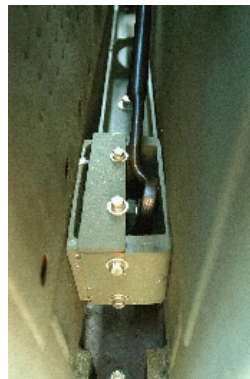

12. Attach two A/C and single D/C 9-foot long electrical power cables using procedures described in WP 0008 00.
13. Ensure that all the climbing steps on the end of the FPU-12 are collapsed and in their upright stowed position prior to performing next step.



WARNING

To prevent personnel injury or death due to falling, there should be no personnel on the roof before proceeding to next step.

14. With two ground guides directing the MHE operator, align the containers to accept the loading rail connectors into the open ends of the load rails on the FPU-8.

CAUTION

Use lumber between the lift carriage and container to protect the end of the container from damage when pushing the container.



15. Slowly move the FPU-8 forward as loading rail connectors penetrate the loading rails. As the FPU-8 approaches the horizontal interconnectors, be sure the jaws on these connectors engage into the opening of the ISO corner blocks on the FPU-8.

CAUTION

Ensure that the power cables do not get pinched between the transverse stabilizer and the container while performing the next task.

16. Continue moving forward until connectors are firmly seated and the loading rail blocks are under the edge of the FPU-8 container.

- Return to the roof via the roof access system located on the roller end of the FPU-8 to tighten the upper horizontal interconnectors.



WARNING

Fall hazards that may cause injury or death exist when climbing onto, returning from or working from the top of the container. Always maintain three points of contact (two feet and one hand, or one hand and two feet) with the folding steps and roof access handle when climbing onto the ASLMS container. All movement should be in the forward direction. Never move, step, or walk backward when working on top of the system. A fall can occur if a worker loses concentration and steps backward off the edge. Stand erect only if necessary, and only away from the edge. Working from a kneeling position helps reduce the threat of a fall. Access to roof by forklift or other MHE is forbidden.

- When the FPU-8/12 containers are mated and the horizontal interconnectors are seated, using a 9/16-inch hex socket, 2½-inch long extension and ½-inch square drive flex head wrench, tighten the locking bolts opposite each other, in a balanced sequential pattern. Tighten until all four horizontal interconnectors are tight and seated. Tightening sequence example:

- Top Right
- Bottom Left
- Top Left
- Bottom Right



- Repeat tightening sequence several times until there is no more bolt movement. Ensure that all four horizontal interconnectors are sufficiently tightened prior to the next steps.

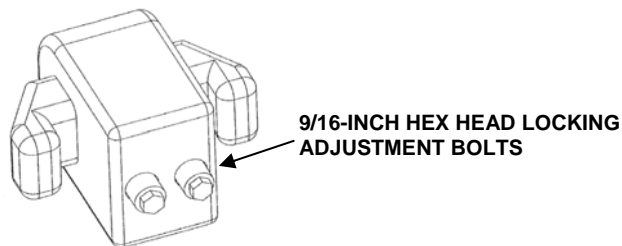

20. The locking adjustment bolts will be recessed and flush with the connector housing when completed.
21. Return to the ground via the roof access system on the end of the FPU-8.
22. After all the connector blocks have been tightened, and using the 1½-inch open end wrench, adjust the transversal stabilizer tensioning blocks between the containers to a very tight condition.
23. Lock down the jam nut after tightening the stabilizer.



WARNING

Make sure all container connectors are properly seated and secured. Failure to comply could cause serious injury, death, or property damage.

OPERATION/INSTALLATION OF BRIDGE LOCKS

Bridge locks are connecting devices that utilize the top openings in the ISO corner blocks. These are an enhancement to the connection of the two containers and are designed to be used strictly during ground transportation. Bridge Locks should be installed whenever the ASLMS is to be transported on the HEMTT, M1076 PLS trailer, container transport trailer, flat bed trailer, etc. Bridge Locks must be removed and stored in the container before hand-off for maritime transportation, aerial port C-130 transport or stacking.

CAUTION

Bridge lock connectors are used in conjunction with horizontal interconnectors for loading and ground transportation, and must be removed for aerial port C-130 transport, stacking, or for maritime shipping, to meet container width and height requirements of ISO certification standards.

The bridge lock has two 2 1/8-inch nuts. The nut in the center is the adjuster nut and opens/closes the locks. The other is the jam nut and secures the locks in position after the adjuster nut has been tightened.

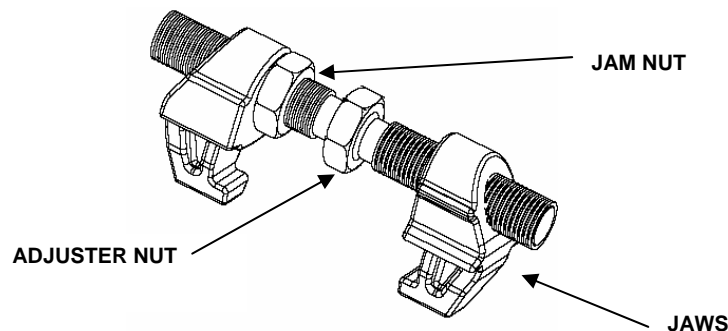

**WARNING**

Fall hazards that may cause injury or death exist when climbing onto, returning from or working from the top of the container. Always maintain three points of contact (two feet and one hand, or one hand and two feet) with the folding steps and roof access handle when climbing onto the ASLMS container. All movement should be in the forward direction. Never move, step, or walk backward when working on top of the system. A fall can occur if a worker loses concentration and steps backward off the edge. Stand erect only if necessary, and only away from the edge. Working from a kneeling position helps reduce the threat of a fall. Access to roof by forklift or other MHE is forbidden.

1. Return to the roof via the roof access system located on the roller end of the FPU-8 to tighten the upper horizontal interconnectors.
2. In a kneeling position, orient Bridge Lock so that jaws are turned towards the installer and jam nut is to the installer's right. Positioning the jam nut to the installer's right will ensure that the installer is pulling when tightening the adjuster and jam nuts.

**WARNING**

Always orient the jam nut to the installer's right to ensure that installer is always pulling toward himself or herself in a safe manner. Improper orientation may result in installer falling from the container roof, causing serious injury or death.

3. Turn the jam nut counterclockwise so that it is positioned close to the adjuster nut.

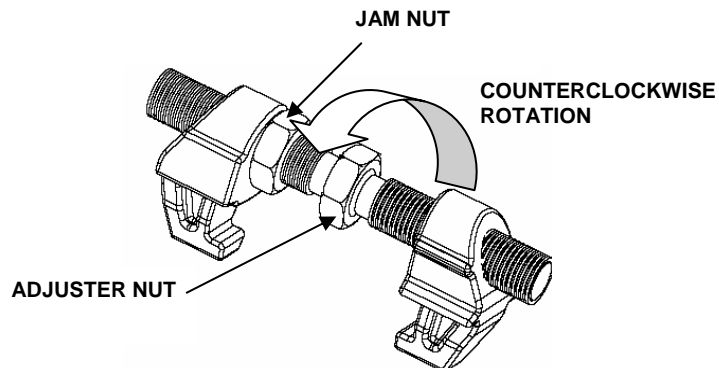

4. Expand/retract adjuster nut until jaws fit into opening at the top of the ISO connector.

5. Place jaws into corner block openings.
6. Tighten jaws using the 2 1/8-inch structural wrench by turning the adjuster nut as tight as possible towards the installer.
7. Turn jam nut towards the closest jaw and tighten counterclockwise firmly.
8. Repeat procedure for opposite side of containers.
9. Return to the ground via the roof access system on the end of the FPU-8.

INSTALLING/REMOVING REAR ROLLER ASSEMBLY

Detachable dual 7-inch rollers are mounted under the rear end of the FPU-8 container and attached to the underside of the lower end rail with two 3/4-inch attaching pins and secured by four linchpins. When attached to the FPU-8 and combined with the FPU-12, the rear rollers enable the container to be loaded on the HEMTT-LHS, and M1076 PLS trailer. The rear rollers are off center in the roller frame so the roller extends past the rear of the FPU-8 frame when installed. When detached and stored within the FPU-12 section, they permit the container to be stacked or transported via standard ISO container transportation methods and devices.

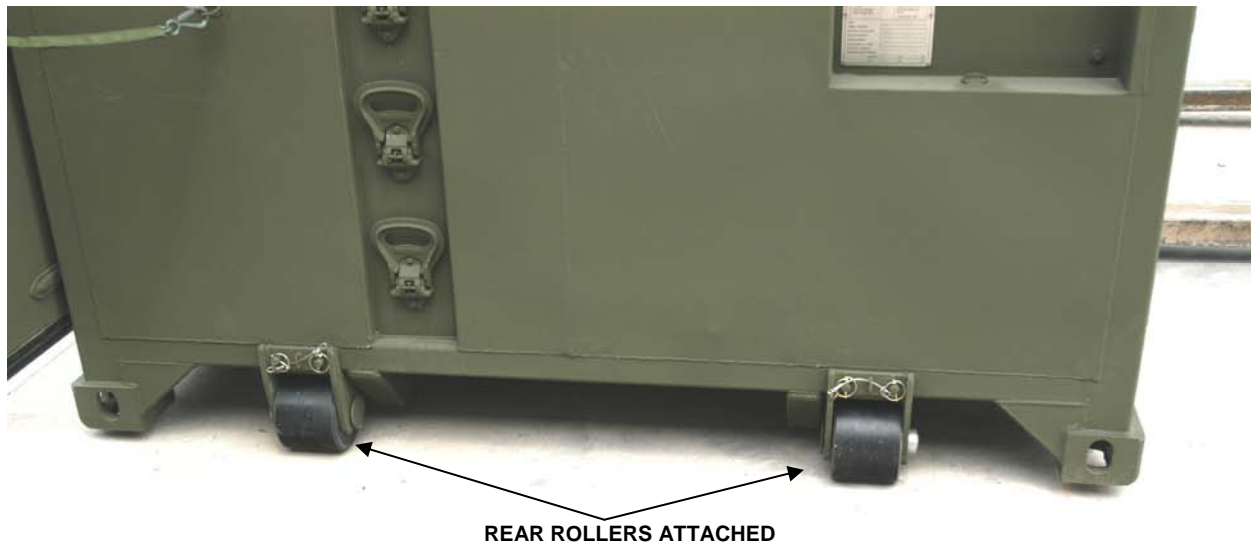

ROLLER INSTALLATION/REMOVAL

After all container connection actions have been successfully completed, the roller assemblies can be installed. This installation will require two people.



WARNING

Do not allow the system to swing if using overhead lift. Always ensure an appropriate sling is used in the lift. Always use properly sized forklift, crane-lifting device. Always use appropriate blocking/bracing in conjunction with proper MHE when working under the container. Failure to comply with these safety measures could cause serious injury or damage to equipment.

Installation

1. Using proper MHE (properly rated forklift or crane), lift the ASLMS container approximately 12-inches off the ground at the FPU-8 end to allow access to the rear frame assembly of the container.
2. Safely block/brace both sides of container with suitable safety support material near rear before proceeding.
3. Position roller assembly, which includes pins, so that the roller extends outside the container frame (lanyard retaining ring with lanyards and linchpins facing away from the container).
4. Person number one fits the roller saddle to the underside of the container frame and aligns the two pinning holes.
5. Second person inserts the two pins through the aligned holes to attach roller assembly to container frame.
6. Secure the two pins in place using the four linchpins attached to the exterior side of the roller assembly.
7. Repeat process for other roller.

Removal

1. Using proper MHE (properly rated forklift or crane), lift the ASLMS container approximately 12-inches off the ground at the FPU-8 end to allow access to the rear frame assembly of the container.
2. Safely block/brace both sides of container with suitable safety support material near rear before proceeding.
3. Remove the four linchpins from the exterior side of the roller assembly.
4. Remove the two pins holding the roller assembly to the container frame.
5. Remove roller assembly from container frame.

INSTALLING THE FORK POCKET ADAPTER PLUG



WARNING

Ensure all container connectors are properly seated and locked. Additionally, ensure all internal material is secured through the use of drawer locking mechanisms, load constraint bars, cargo strap/netting, pallet lock rods, module locking devices (WP 0006 00 and 0007 00). Failure to comply could cause serious injury, death or property damage.



WARNING

To prevent serious personal injury, the HEMTT truck should be turned off, have the brakes set, and wheels chocked prior to performing this task.

The installation of the fork pocket adapter plug is accomplished after the ASLMS has been loaded onto the M1076 PLS trailer. With ASLMS securely positioned on the M1076 PLS trailer, fork pocket adapter plugs can be inserted into forward fork pocket openings of the FPU-8 container. This fork pocket adapter plug is installed when it is to be loaded onto an M1076 PLS trailer and is to be transported by rail.

NOTE

Fork Pocket Adapter plugs are hand oriented. With the yoke-attaching bracket facing outward, the 1½-inch pinning hole will always be closest to the front of the container.

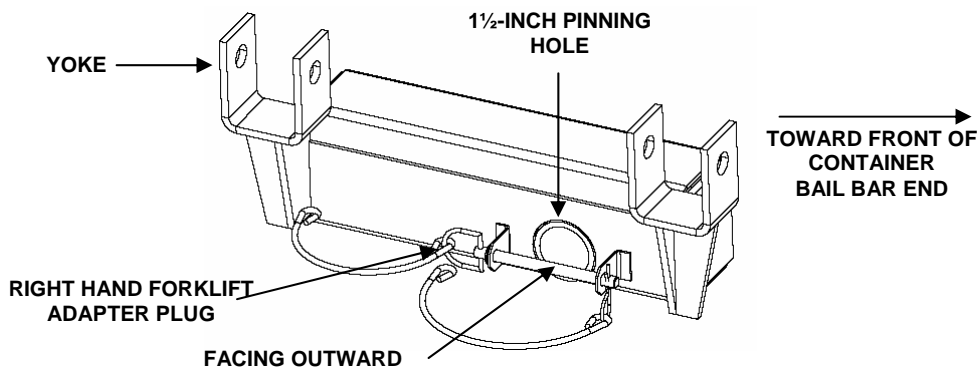

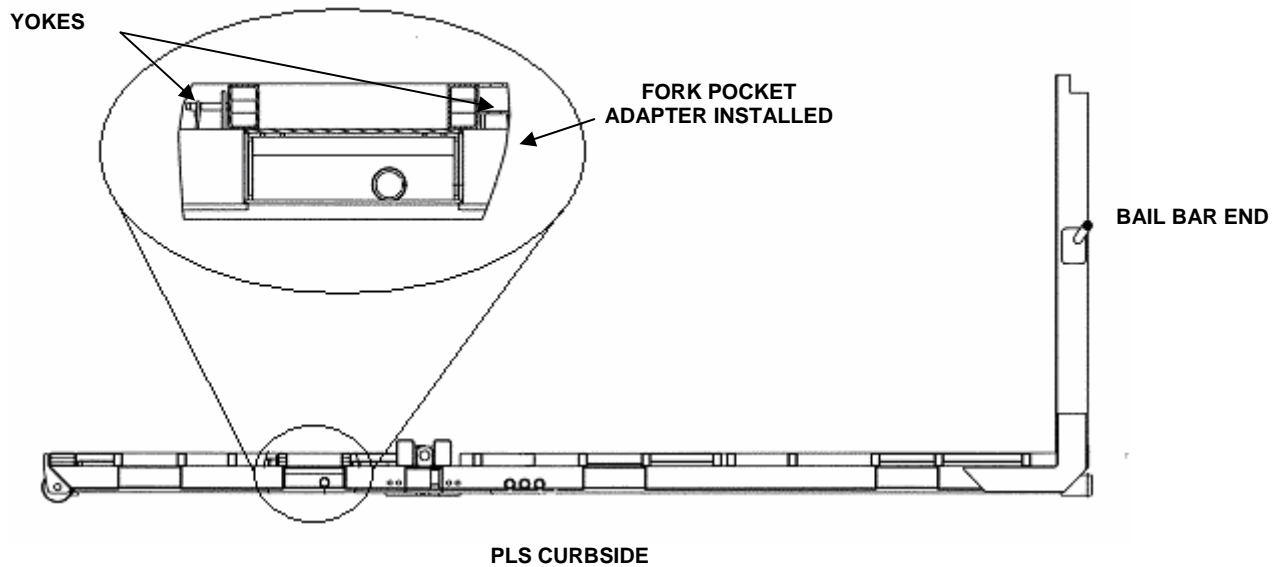

INSTALL/REMOVE

1. Select the proper forklift adapter plug to be installed, depending on the side being installed. An improper plug will not align properly.
2. Position yoke to saddle under container cross-members at proper fork pocket opening.
3. Slide fork pocket adapter plug into fork pocket opening until yoke retainer holes align with mating holes in cross-members.
4. Insert the two ½-inch connector pins and secure with spring wire retainers.
5. Repeat steps 1 through 4 for the roadside.

SECURING ASLMS TO PLS TRAILER

CAUTION

Caution must be exercised when transporting the ASLMS on the M1076 PLS trailer on cross-country terrain that can produce excessive vibration and shock. When conditions simulate the 6-inch washboard effect, damage may result to the ASLMS container and the material stored within, when driving at excessive speed for this condition. Operators should always adjust driving speed to local conditions for safe operation. If a 6-inch washboard effect is encountered, it may be necessary to reduce speed to as low as 3 miles per hour to avoid damaging the ASLMS and its contents.

1. After loading the ASLMS on to the M1076 PLS trailer, pinning holes must align with mating holes in M1076 PLS trailer frame. If these do not align, recheck orientation of rear roller assembly and fork pocket adapter plugs. Ensure rollers on rear roller assemblies contact the roller stops on the M1076 PLS trailer. Correct as necessary.

NOTE

Refer to the M1076 PLS trailer TM to determine when the PLS trailer load securing pin is to be used.

2. Remove the 1½-inch diameter PLS trailer load securing pins and insert into fork pocket adapter plug pinning holes.
3. Secure PLS load securing pins in place by inserting the 3/8-inch by 4-inch long hitch pins through pin retainer brackets.
4. Secure hitch pins by inserting hairpin into hitch pin safety hole.

END OF WORK PACKAGE

OPERATOR'S, UNIT, AND DIRECT SUPPORT MAINTENANCE**AUTHORIZED STOCKAGE LIST MOBILITY SYSTEM (ASLMS)**

MODEL NUMBER FPU-8/12 PARTS (OD) P/N 15005002-001
NSN 5411-01-523-2071

MODEL NUMBER FPU-8/12 PARTS (DS) P/N 15005002-002
NSN 5411-01-523-2072

MODEL NUMBER FPU-8/12 BULK (OD) P/N 15005001-001
NSN 5411-01-523-2073

MODEL NUMBER FPU-8/12 BULK (DS) P/N 15005001-002
NSN 5411-01-523-2074

OPERATION OF ASLMS CONTAINERS

OPERATION OF ASLMS CONTAINERS

This work package provides procedures associated with safe and efficient operation of the ASLMS/FPU components. Familiarity with these procedures will allow military units to derive maximum benefit from ASLMS modularity and the options for FPU configuration.

FPU-8 CONNECTED TO FPU-12

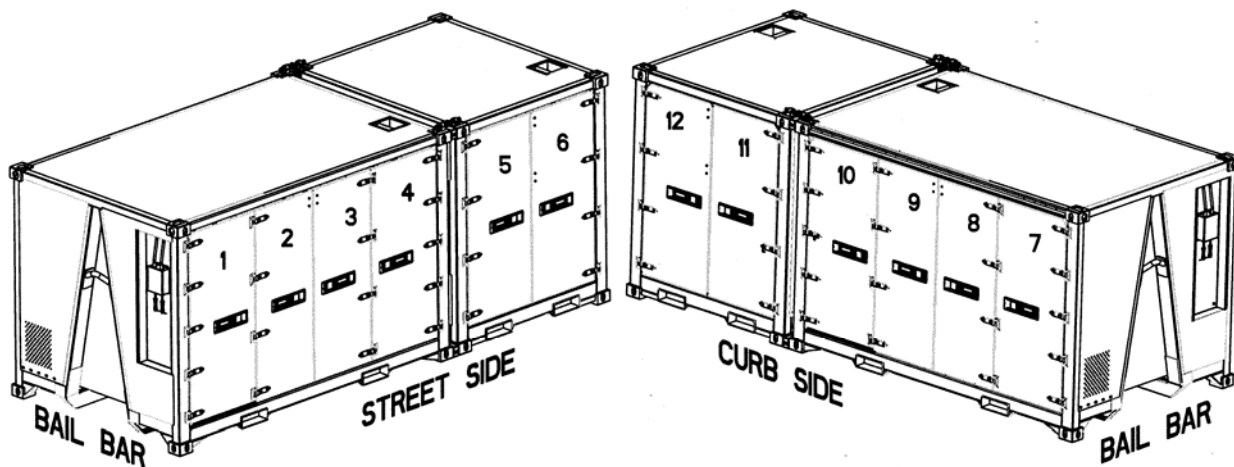

OPERATION OF ASLMS DOORS

Opening the Doors

WARNING



Container should be operated on level ground and periodically checked for shifting from a level position. Use care when opening doors, as physical injury may occur. To maintain control, consider ground surface conditions that may not provide adequate traction, such as mud, snow, ice, sand. Seek assistance from fellow soldiers to prevent impact or strain injury.

Doors on the FPU-8 should be opened simultaneously. When opening the FPU-12, open the left and right center bi-fold doors street side (2 and 3), or the curbside bi-fold doors (9 and 8) simultaneously, then open both left and right street side doors (1 and 4) or the curbside doors (10 and 7).

CAUTION

When closing the FPU-12 center doors or the FPU-8 doors always allow the right hand door to lead slightly to mate with the door seal edges and prevent damage to the seals.

CAUTION

The ASLMS containers will exceed the ISO width requirement if a heavy security padlock is used to secure the exterior doors. Padlocks not exceeding one-inch thickness will allow the width requirements to be met. Padlocks may be taped to the exterior doors to further ensure measurements stay within the ISO envelope.

FPU-8 Container

1. Using your right palm for left-hand doors and left palm for right hand doors, depress locking latch while using your free hand to prevent handle from springing outwards.

WARNING



The container door release grip has limited room for hand space. This creates a pinch point at the handles when closing the door. Place the door handles in the closed position after opening the doors so the doors will fold against each other.

2. Rotate both handles to their full open position.
3. Pull both handles simultaneously. Because containers are constructed with tubular steel and are subject to flexing when containers are sitting on a non-level surface, doors may be difficult to open. In this event you may require the assistance of other personnel to open the doors.

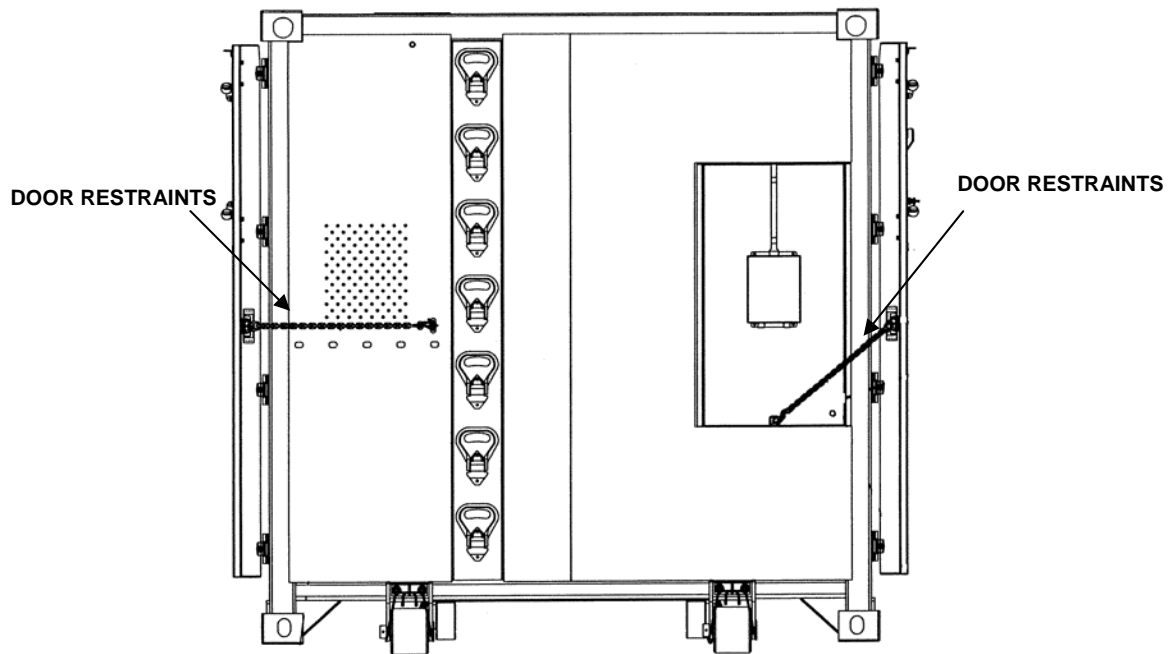

CAUTION

After doors are open, door handles must be re-latched in their closed position to prevent equipment damage to handles as doors are folded back into the open position.

4. The FPU-8 end container doors are retained by fabric-covered chains shackled to welded rings on the end and interior of the door. Secure doors using door restraints.



WARNING

To prevent injury to personnel, after opening each door install door restraints to prevent accidental closing due to wind, or when container is resting on a non-level surface.

FPU-12 Container

**WARNING**

The container door release grip has limited room for hand space. This creates a pinch point at the handles when closing the door. Place the door handles in the closed position after opening the doors so the doors will fold against each other.

1. Using your right palm for left-hand doors and left palm for right-hand doors, depress locking latch while using your free hand to prevent handle from springing outwards.

NOTE

Unlatch all four doors prior to attempting to open doors. Unlatching all door handles will assist in unseating doors.

2. Rotate handles to their full open position.

CAUTION

When doors are open, door handles must be latched in closed position to prevent equipment damage to handles as doors are folded back in the open position.

3. Grasp both the center door handles and pull bi-fold doors simultaneously. Because containers are constructed with tubular steel and are subject to flexing when containers are sitting on a non-level surface, doors may be difficult to open. In this event you may require the assistance of other personnel to open the doors. While pulling on center doors simultaneously, have additional personnel pull handles on doors.
4. Fold doors and retract away from the container.
5. The FPU-12 end container doors are retained by chains or straps shackled to welded rings on the end and interior of the door. Secure doors using door restraints.

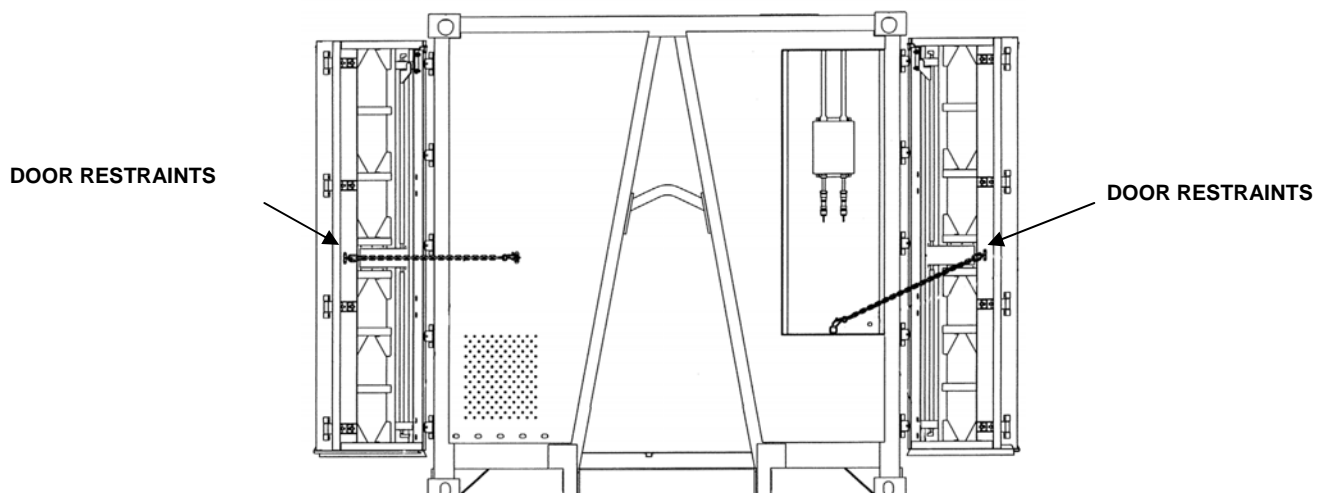



WARNING

To prevent injury to personnel, after opening each door install door restraints to prevent accidental closing due to wind, or when container is resting on a non-level surface.

FPU-8 and FPU-12

The center set of FPU-12 and FPU-8 doors are retained by a strap that goes across the door edges and are shackled to a ring welded to the interior of the door.

NOTE

When the FPU-8 and FPU-12 containers are separated they each have additional rings that are welded on the end of each container to accept the strap shackles.

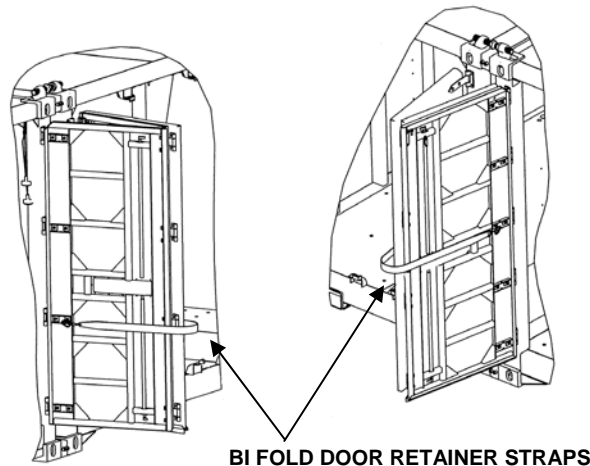

1. Disconnect door restraint devices from doors. Doors should be in perpendicular position for ease of restraint removal.
2. Hook restraints to the doors.

WARNING



To prevent injury to personnel, caution should be exercised when releasing more than one door at a time from door restraints during the closing procedure.

3. Unlatch door handles by depressing the locking latch, and rotate handles to their full open position.
4. For the FPU-12 only, first close and latch both outer doors (1 and 4) street side, or 10 and 7 curbside, then close both bi-fold doors (2 and 3) curbside, or 9 and 8 street side, simultaneously aligning the

- single seal lip of the right door (3) street side or 8 curbside, to be slightly ahead of the double seal lip left door (2) street side or door 9 curbside.

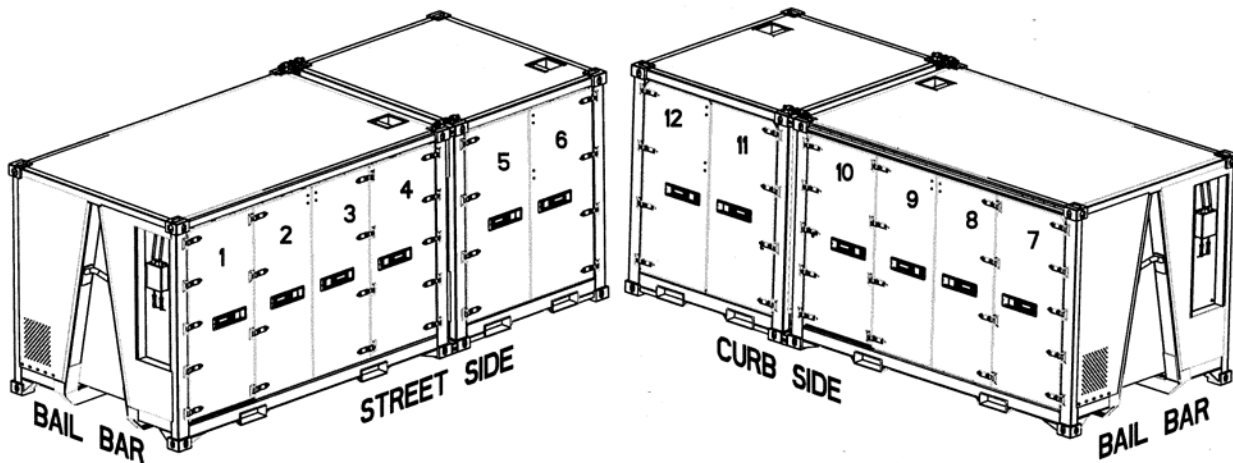

CAUTION

During the closing process, as the overlapping doors begin to mate, be sure that the door with no outer seal lip (right side) is ahead of the double seal lip door (left side) to ensure proper closing and to prevent damage to seal.

- Push firmly until the door cams engage the door cam keepers inside the container.
- Rotate door handles to the full closed position. Ensure that the locking latch has fully engaged the handle.

NOTE

If the top or bottom of the door does not seat inside the doorframe, the doors have not made proper contact with the door cam keeper.

CAUTION

When doors are open, door handles must be latched in closed position to prevent equipment damage to handles as doors are folded back in the open position.

Closing the Doors

ASLMS door seals consist of a double lip design in which the inner lip forms a tight seal against a fixed surface around the door opening while the outer seal overlaps the door facing to provide a double sealing protection against the environment. Overlapping doors require one door (left side) to have double seal lips while the adjacent door (right side) has a single seal lip (no outer seal lip). During the closing process, as the overlapping doors begin to mate, be sure that the door with no outer seal lip (right side) is ahead of the double seal lip door (left side).

CAUTION

Prior to beginning the door closing procedure, ensure that the container threshold is completely free of debris (dirt, sand, gravel, etc.). This will provide for proper sealing of the doors and prevent leaks.

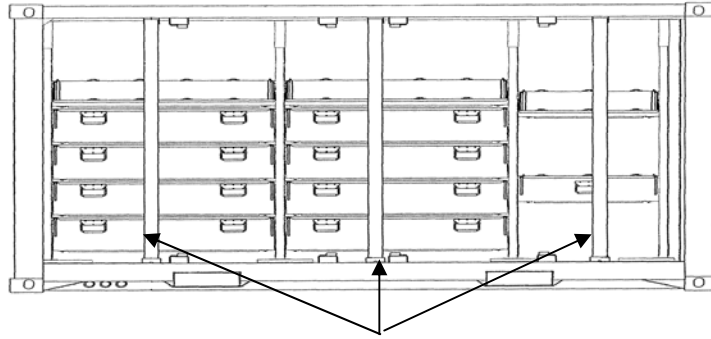
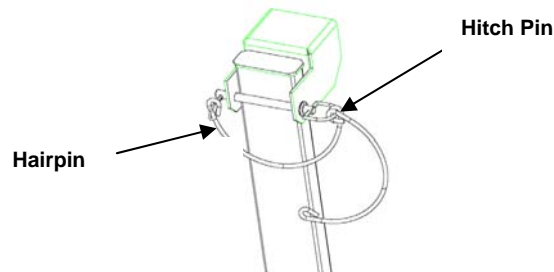
REMOVING/INSTALLING ASLMS LOAD CONSTRAINT BARS (FPU-12P ONLY)**LOAD CONSTRAINT BARS****NOTE**

Constraint bars are not provided nor required for ASLMS bulk pallet containers.

Load constraint bars are designed to keep drawers from sliding out during transport. The load constraint bars are located in the center of each row of drawers. Load constraint bars are full height vertical bars fitting into a lower receptacle and retained in place using a pin system located at the top of the bars.

1. Open doors IAW WP 0006 00.
2. Remove the hairpin.
3. With one hand, retain constraint bar into position.
4. Grasp the hitch pin with free hand and remove. Hitch pin is secured to the restraint bar by a security lanyard, and so may be released after removing.
5. With both hands, remove the load constraint bar from its receptacle.

**WARNING**

Fall or tripping hazard may exist when the load constraint bars are not properly stowed during operation. Ensure that load constraint bars do not protrude when stowed.

6. Load constraint bars should be stowed on the floor under 12-inch parts drawers of the FPU-12P container.

NOTE

Ensure lower receptacle is clean of debris before beginning this process.

OPERATING ADJUSTABLE DRAWERS (FPU-12 PARTS ONLY)

Adjustable drawer slide ledges have been installed in the FPU-12 parts container. These slide ledge assemblies are attached to the vertical rack frame at two locations by four 5/16-inch Allen bolts at each point of attachment. Drawers are mounted to these ledges by four bolts on each ledge.

All drawers are full extension and are operationally secured by locking rod handles to prevent opening during transport or accidental closing during use. Drawers consist of fixed longitudinal dividers and moveable transversal dividers that allow adjustment on two-inch centers. Drawers are rated with a maximum capacity weight limit of 150 lbs per drawer.

CAUTION

Do not exceed maximum weight limit of 150 lbs per drawer. Exceeding load limits may damage slide and drawer systems.

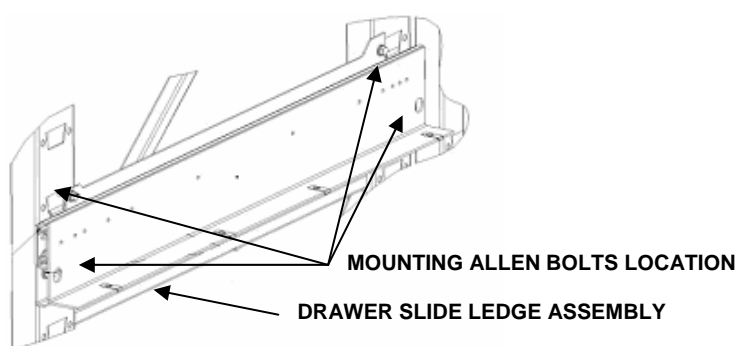

Opening and Closing Drawers (FPU-12 only)



WARNING

Container must be operated on level ground and periodically checked for shifting from a level position. Use care when opening drawers, as physical injury may occur. To maintain control, consider ground surface conditions that may not provide adequate traction, such as mud, snow, ice, sand. Seek assistance from fellow soldiers to prevent impact or strain injury.



WARNING

Fall hazard. Do not use bottom drawers or pallets as step substitutes when trying to access material located in upper drawers and pallets. It is recommended that an optional stepladder with hand rail be used to access upper drawer and pallet material.

**WARNING**

The drawer release/locking mechanism grip has limited room for hand space. This creates a pinch point at the handles when releasing or locking drawers.

CAUTION

Never allow material to exceed the height of the drawer sides. Material exceeding drawer height will interfere with travel of that drawer and the drawer above.

Opening

Rotate the two locking mechanism handles upward toward the center of the drawer and hold in the open position. Pull out until the locking handles can be released to lock the drawer in the open position.

NOTE

Drawers will lock in both the closed and fully extended position.

Closing

Rotate the two drawer locking handles upward toward the center of the drawer and hold in the open position. Push the drawer in until the locking handles can be released to lock the drawer in the closed position. Use drawer handles, not locking mechanism handles, to open and close doors.



Moving/Adjusting Drawer Dividers

Drawers consist of fixed longitudinal dividers and moveable transversal dividers that allow adjustment on 2-inch centers from front to rear. To move a divider, grasp each side of the divider at the top and pull upward until free. Select the desired position and insert divider into slots on drawer. Be sure divider is inserted into slots directly across from each other. Twelve-inch drawers consist of multiple slots for maximum retention of divider. Ensure divider is engaged in all the slots at the chosen location and is seated completely on the drawer bottom surface.

Repositioning Drawers (FPU-12 Parts only)

1. Fully extend and lock the drawer in open position (If drawer will not stay in the open position this task will require two people. One person will hold the drawer in the extended position, and the other will perform the drawer removal task).
2. Remove all stored material from drawer.
3. Remove eight 1/4-inch screws located in the bottom of the drawer at either side.

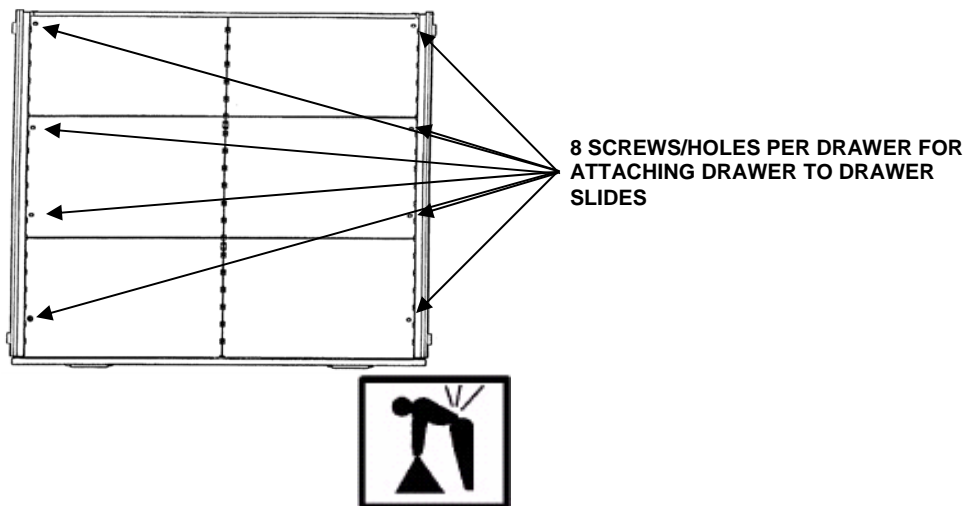

WARNING

The drawers are heavy and awkward to handle by a single person. The adjustment of these items requires two or more persons to move or install. To further lessen risk of injury, lift with the legs, not the back.

4. Lift drawer from slide ledges.

CAUTION

If a screw is lost or damaged beyond use, obtain a replacement. Do not install with less than the proper number of screws or equipment damage may occur.

5. Remove four 5/16-inch diameter Allen head bolts, using 3/16-inch Allen socket and 3/8-inch ratchet with extension, from the slide ledge and vertical rack frame at each point.
6. Slide ledges are retained on the vertical rack frame by four bayonet tabs protruding into the windows of the vertical rack frame. This requires the ledge to be loosened from the vertical rack frame. While

7. one person securely holds the slide ledge, the second person applies an upward force by tapping the underside of the ledge at the attached point with a 2 X 4 soft wooden block or similar material.
8. Place the drawer slide ledges in their desired positions by inserting the tabs into the vertical rack frame windows and tapping them downward with a 2 X 4 soft wooden block or similar material. Be careful to align boltholes, with appropriate threaded holes, in the vertical rack frame.

NOTE

Drawers may be adjusted in 4-inch increments.

9. Reattach drawer slide ledge to rack frame using four 5/16-inch diameter Allen bolts using 3/16-inch hex driver socket and 3/8-inch ratchet with extension.
9. Extend drawer slides to their fully extended position.
10. Reposition the drawer onto the slide ledge, being careful to align mounting holes.
11. Install all eight screws and hand-tighten only.
12. After hand tightening and prior to full tightening of the eight ¼-inch mounting screws, push drawer completely closed and pull back to its fully extended position to allow the drawer to seat into its proper location on the drawer slide ledge.
13. Being careful not to over-tighten, secure the eight ¼ -inch mounting screws.

OPERATING ASLMS PALLETS (FPU-12/8 BULK ONLY)

Each pallet position in the pallet rack system consists of a pallet and left and right load-centering adjustable pallet mounting ledges. Ledge assemblies are attached to the vertical rack frame at two locations by eight 5/16-inch Allen bolts. When pallets are inserted on pallet ledges, they are secured by rear cam locks and held in front by two adjustable lock rods that seat the pallet into position when tightened. All pallets are provided with nets or ratchet straps to secure material. Pallets are rated with a maximum capacity weight limit of 1,000 lbs.



WARNING

Never work underneath loaded pallets. Failure to comply could cause serious injury or death.

CAUTION

Do not exceed maximum weight limit of 1,000 lbs per pallet. Exceeding load limits may damage pallets and pallet ledges.

CAUTION

Ensure the lock rods have been completely retracted prior to removing or inserting the pallets.

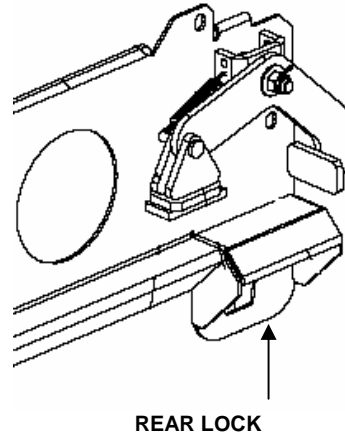
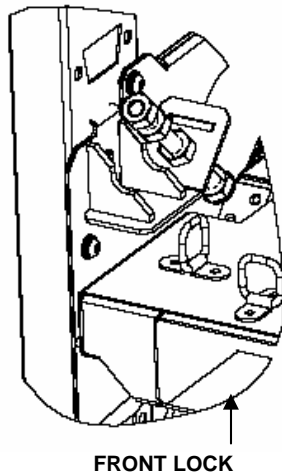

WARNING

Standard forklift principles apply when working with or on the FPU containers. Work with ground guides during the loading or unloading of the pallets. Never move the pallet into the FPU container while the ground guide is in between the forks or pallet of the FPU container. Forklift operators must maintain visual contact with the ground guide at all times. Serious injury or death could occur if the ground guide is pinned between the forklift and the pallet or FPU container.

Inserting Pallets

The following process will require a forklift operator and a ground guide.

1. Adjust forklift tines to match fork pockets of pallet to be installed.
2. Pick up pallet with forklift.

NOTE

Pallets are designed with a forklift tine stop to ensure proper distance is maintained between the forklift bridge and the ASLMS container. The stop also assists in inserting the pallet to the rear locked position.

3. Using the ground guide, align pallet to the pallet ledge opening.

CAUTION

Ensure the lock rods have been completely retracted prior to removing or inserting the pallets.

3. Once approximately 12-inches into the pallet ledge, lower the pallet and allow it to slide along the pallet ledge into the lock position.
4. Retract forklift.
5. Tighten the lock rods evenly using 7/8-inch deep well socket and ½-inch drive flex head wrench to secure the front of the pallets.

NOTE

Alternate tightening left to right to ensure proper alignment of pallet on pallet ledges.

6. Tighten jam nut using 7/8-inch combination wrench to hold lock rod in the closed position.

Removing Pallets

1. Loosen jam nuts using 7/8-inch combination wrench.

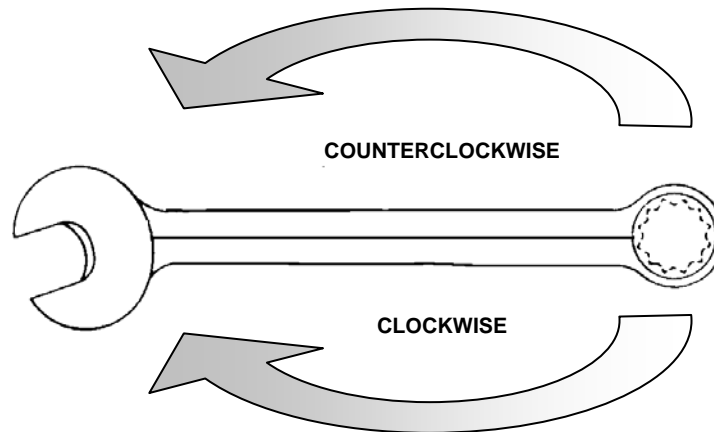

NOTE

All hardware, bolts, jam nuts, and screws are loosened with a counter clockwise rotation. All hardware, bolts, jam nuts, and screws are tightened with a clockwise rotation.

2. Completely retract lock rods using 7/8-inch deep well socket and 1/2-inch drive flex head wrench. Turn lock rods counterclockwise fully until retracted. The rod will bottom out when fully retracted.



WARNING

Standard forklift principles apply when working with or on the FPU containers. Work with ground guides during the loading or unloading of the pallets. Never move the pallet into the FPU container while the ground guide is in between the forks or pallet of the FPU container. Forklift operators must maintain visual contact with the ground guide at all times. Serious injury or death could occur if the ground guide is pinned between the forklift and the pallet or FPU container.

3. Adjust forklift tines to match fork pockets of pallet to be removed.
4. Using the Ground Guide, insert tines into pallet until contact with pallet stops is made.
5. Using one of the 2-inch ratchet straps provided, attach one hook to left front pallet D-ring.
6. Feed strap through the forklift bridge to opposite side and attach to right front pallet D-ring.
7. Raise the forks approximately 1-inch.
8. Back out slowly approximately 12-inches to allow pallet to clear rear cam lock.
9. Tilt forks back to obtain approximately 1-inch of clearance between the pallet and pallet ledge.

10. Continue backing out until clear. Once clear of container, position pallet to desired location and lower to the ground.
11. Disconnect ratchet straps from pallet D-rings and remove from forklift bridge.

Adjusting Pallet Position



WARNING

Never work underneath loaded pallets. Failure to comply could cause serious injury or death.

1. Unload and remove all pallets located above as well as the pallet to be relocated prior to beginning the following steps (refer to pallet inserting/removing procedures).
2. Remove front and rear pallet ledge stabilizer by turning attaching bolts counterclockwise on each side of the stabilizer using 3/16-inch hex driver socket and 3/8-inch ratchet with extension.

NOTE

The operator must crawl into the container to remove the rear Allen bolts.

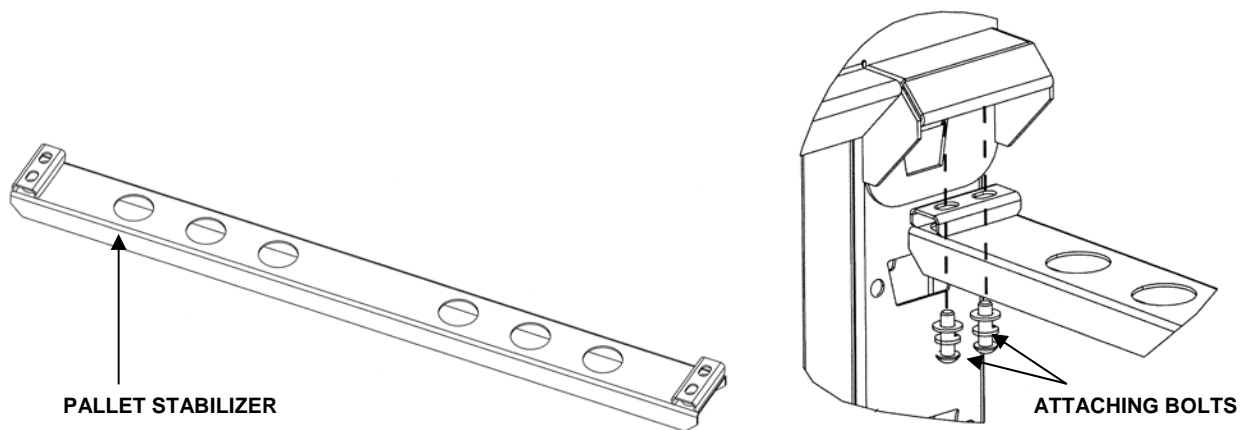

3. Remove eight Allen bolts using 3/16-inch hex driver socket and 3/8-inch ratchet with extension from the two pallet ledges on the vertical rack frame.

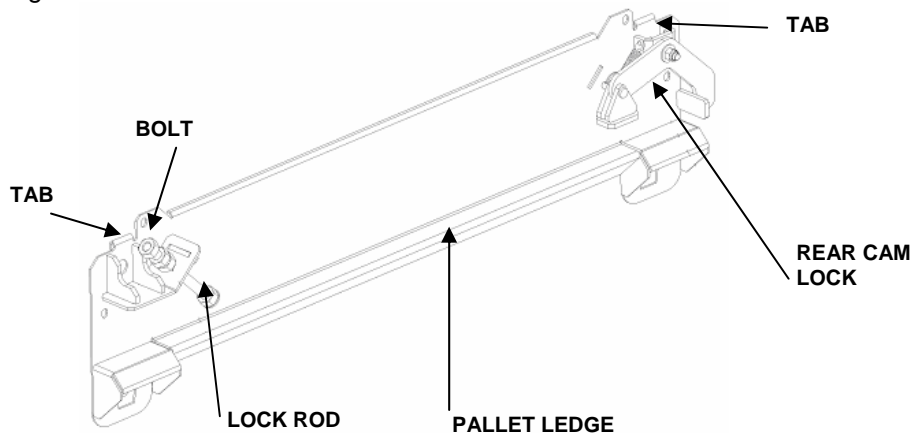

CAUTION

If a bolt is lost or damaged beyond use, obtain a replacement. Do not install with less than the proper number of bolts or damage to equipment may occur.

4. Pallet ledges are retained on the vertical rack frame by four bayonet tabs protruding into the windows of the vertical rack frame. This requires the ledge to be loosened from the vertical rack frame. While one person securely holds the pallet ledge, the second person applies an upward force by tapping the underside of the ledge at the attached point with a 2 X 4 soft wooden block or similar material.
5. Place the pallet ledges in their desired positions by inserting the tabs into the vertical rack frame windows and tapping downward with a 2 X 4 soft wooden block or similar material. Ensure that pallet ledges in the vertical rack frame are at same height. Ensure all tabs have engaged the vertical rack frame windows before tapping into place. Be careful to align boltholes with appropriate threaded holes in the vertical rack frame.

NOTE

Pallets may be adjusted in 4-inch increments.

NOTE

Apply Loctite 262 Red on bolt threads of all bolts before reinstalling.

6. Reinstall the eight Allen bolts (finger tighten only).
7. Tighten all bolts using 3/16-inch hex driver socket and 3/8-inch ratchet with extension from the two positions of each pallet ledge. Four bolts are located at each vertical rack frame.
8. Reinstall rear pallet ledge stabilizer using the four Allen bolts, finger-starting all bolts before tightening.
9. Tighten all bolts using 3/16-inch hex driver socket and 3/8-inch ratchet with extension from the two positions of each pallet ledge. Four bolts are located at each vertical rack frame.
10. Reinstall front pallet ledge stabilizer using the four Allen bolts, finger-starting all bolts before tightening.
11. Tighten all bolts using 3/16-inch hex driver socket and 3/8-inch ratchet with extension from the two positions of each pallet ledge. Four bolts are located at each vertical rack frame.
12. Reinstall pallet, ensuring cam lock is properly seated.
13. Retighten locking rod.

SECURING ASLMS CARGO USING NETS (2-foot Drawers and HAZMAT Pallets Only)

ASLMS cargo netting is attached to HAZMAT pallets and the tops of 2-inch parts drawers, and is then tightened around the stowed material by means of adjustable straps with parachute clips.

1. Place material to be secured in the 2-inch drawer or in HAZMAT pallet.
2. Arrange net to ensure male and female parachute clips are aligned.
3. Attach the male ends of the parachute clips located on nets to the female clips located on the pallet.
4. Pull loose ends of the straps to remove slack.
5. To remove, detach parachute clips.

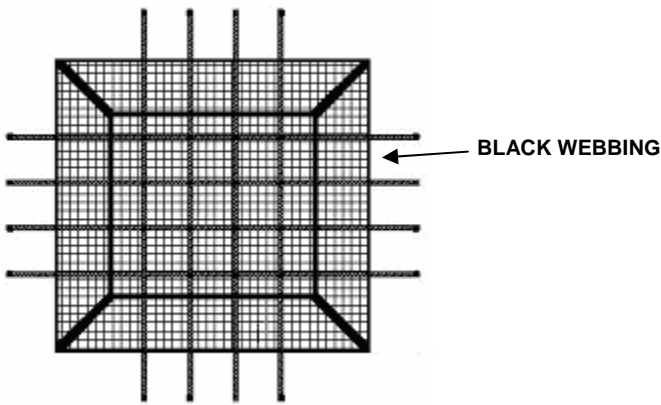

WARNING

Some HAZMATs may react negatively with other HAZMATs. The MSDS for each type of hazardous material to be shipped must be referenced prior to shipment. All recommended chemical compatibility, segregation, and safety procedures must be followed. Be sure to use the appropriate absorbent material inside the containers to absorb spills. All HAZMATs must be double wrapped prior to shipment in lined HAZMAT storage pallets. Failure to do so may result in a violent chemical reaction that could cause damage to pallets, ASLMS cargo, or hardware and injury or death to personnel.

SECURING ASLMS CARGO USING FLOOR NETS (FPU-12 Bulk Only)

ASLMS floor cargo nets are designed to secure cargo directly to the floor of the FPU-8/12 Bulk containers and consist of a net with four safety snaps positioned to fit into the recessed rings located at the bottom of the vertical rack frames. An adjustable cinch rope runs along the outer edge of the net.

There are three sizes of floor cargo nets:

- Two large (used in FPU-8 Bulk containers)
- Four medium (used in FPU-12 Bulk containers)
- Two small (used in FPU-12 Bulk containers)

1. Remove pallets directly above the position in which the cargo is to be secured (refer to WP 0006 00 for additional information).
2. Insert load to be stored and secured.
3. Align net and attach the two safety snaps to the two rear rings of the vertical rack frame.
4. Feed the net over and around the load.
5. Attach the remaining two safety snaps to the two front rings of the vertical rack frame.
6. Pull cinch rope tightly to secure load in place.

SECURING ASLMS CARGO USING RATCHET STRAPS

ASLMS pallets are designed with a series of D-rings around their edges. Pallets (except HAZMAT Pallets) are provided with four 2-inch ratchet straps that utilize a tension ratchet and snap hook ends to secure. These straps hook directly on to the D-rings. Proper position of these straps depends on size and shape of the material stored on the pallet.

Ratchet Strap

1. Extend the ratchet strap and fasten one snap hook end to one of the pad eyes on the edge of the pallet and extend the strap over the material to be secured until you can connect the other snap hook end to another pad eye on the opposite side of the pallet.
2. Grasp the loose end of the blue strap and take-up the slack in the drum and strap until the strap has firm contact with the material.
3. Use the ratchet handle to tighten and add tension to secure the material.
4. To remove the straps, grasp the tension release bar and pull toward the handle.

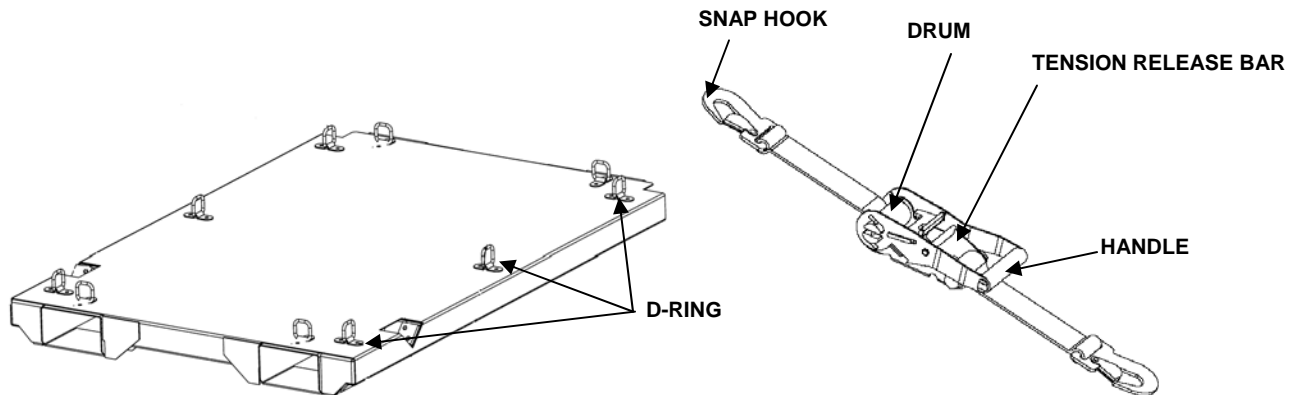

OPERATING VENTILATION SYSTEM

A closeable, solid-matter-filtered, free-air-exchange ventilation device provides fresh air and ensures pressure equalization during heat buildup or when the container is moved via aircraft. The ASLMS has a series of filter cover plates that allow the vents to be closed.

1. To operate the filter cover plate, first locate the red and black pull handles inside the top ends of the container.
2. Pull the red-banded handle to release the filter cover plate. This will close the vent.
3. Pull the black handle to relock the filter cover plate in the open position. The filter cover plate should only be set in the closed position when there is a threat of chemical or biological attack or during extremely adverse weather conditions.

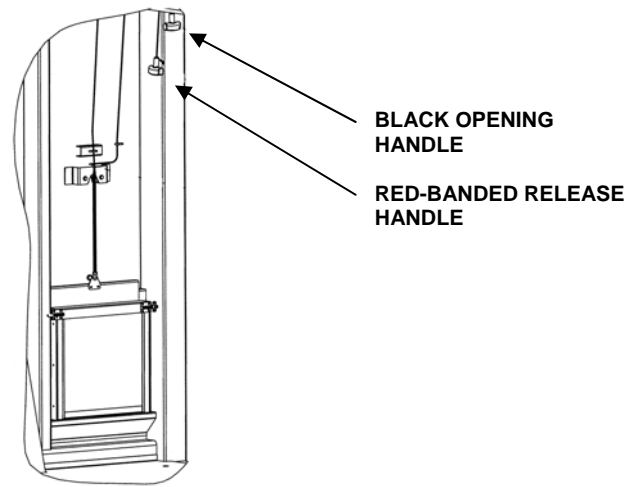

FLOOR ADAPTER PLATE

Each floor adapter plate secures two ASLMS modules in the FPU-8 Parts container using four receptacles with rubber pads and a center twist lock. The center twist lock connects to a female receptacle located on the bottom of ASLMS modules. Floor adapter plates are affixed to the FPU-8 Parts container using twelve hex head bolts.

To lock ASLMS modules into the FPU-8 Parts container with floor adapter plate installed, push the red handle completely in after module has been installed into position.

To remove the modules, unlock the module by pulling the red handle completely out.

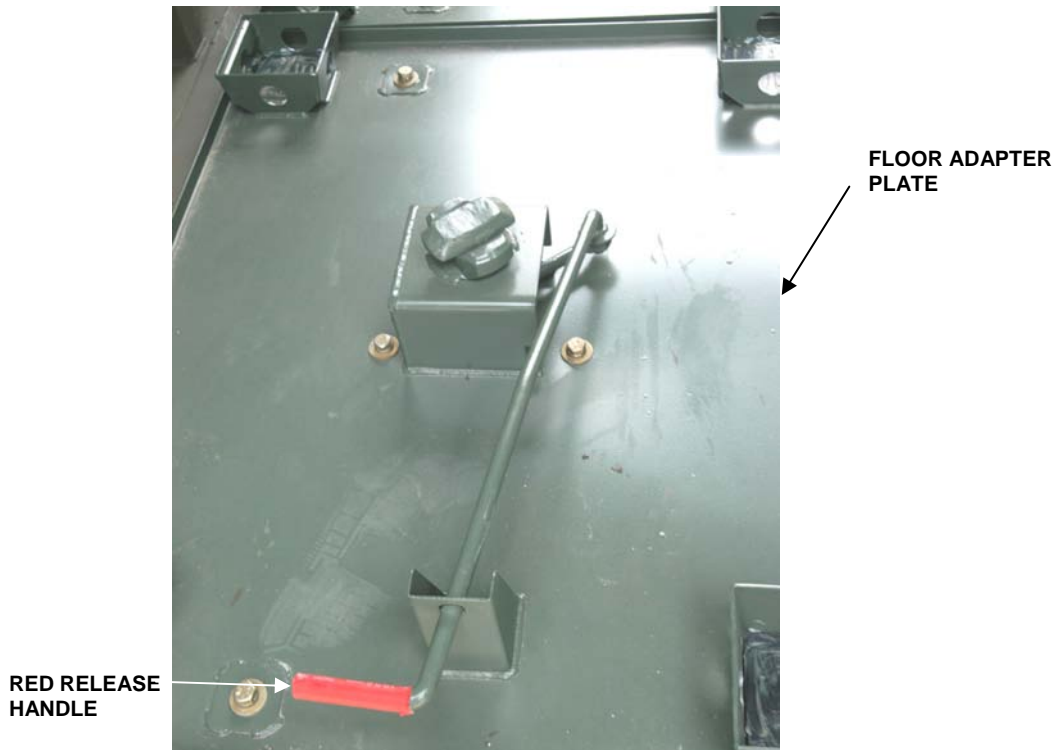

END OF WORK PACKAGE

OPERATOR'S, UNIT, AND DIRECT SUPPORT MAINTENANCE**AUTHORIZED STOCKAGE LIST MOBILITY SYSTEM (ASLMS)**

**MODEL NUMBER FPU-8/12 PARTS (OD) P/N 15005002-001
NSN 5411-01-523-2071**

**MODEL NUMBER FPU-8/12 PARTS (DS) P/N 15005002-002
NSN 5411-01-523-2072**

**MODEL NUMBER FPU-8/12 BULK (OD) P/N 15005001-001
NSN 5411-01-523-2073**

**MODEL NUMBER FPU-8/12 BULK (DS) P/N 15005001-002
NSN 5411-01-523-2074**

LOADING/UNLOADING ASLMS MODULES

LOADING/ UNLOADING ASLMS MODULES (FPU-8P ONLY)

The ASLMS module system consists of a storage/shipping module and a floor adapter plate. ASLMS modules are designed to be easily installed/removed from the ASLMS FPU-8 Parts container having a floor adapter plate installed. Modules consist of four tapered feet and a female receiver located on the bottom that allows them to be mounted directly to the floor adapter plate. Modules are retained in place using twist lock on the floor adapter plate. Modules are locked on to the floor adapter plate by pulling out or pushing in on the module-locking arm. Floor plate adapters provide four module storage positions.

Removing ASLMS Modules

1. Ensure modules basket doors are secured in the closed position and 3-G bar is pinned in place.



2. Pull the red module-locking arm handle fully out to its open position.



WARNING

Standard forklift principles apply when working with or on the FPU containers. Work with ground guides during the loading or unloading of the pallets. Never move the pallet into the FPU container while the ground guide is in between the forks or pallet of the FPU container. Forklift operators must maintain visual contact with the ground guide at all times. Serious injury or death could occur if the ground guide is pinned between the forklift and the pallet or FPU container.

3. Adjust forklift tines to fit forklift pockets on the ASLMS module.



4. With the assistance of a ground guide, insert tines into module.

NOTE

Be sure to enter the forklift pockets with tines above the red handle.

5. Lift module directly upward maintaining a level position to a height just above the module receptacles on the floor adapter plate.
6. Using ground guide, slowly back out paying close attention to the guide and the upper clearance between the basket and container door cam keeper that protrudes downward from the top of the container frame. The module may have to be raised or lowered during this process if the tilt is too far forward or backward.



7. Continue backing until completely clear of the container.
8. Transport to desired drop area and slowly lower until the module is resting fully on the ground.
9. Slowly back away until completely clear of the module.

Inserting ASLMS Modules

1. Be sure module basket doors are secured in the closed position and 3-G bar is pinned in place.
2. Be sure red handle on the module-locking arm located on the floor adapter plate is pulled fully out to its open position.



WARNING

Standard forklift principles apply when working with or on the FPU containers. Work with ground guides during the loading or unloading of the pallets. Never move the pallet into the FPU container while the ground guide is in between the forks and the pallet of the FPU container. Forklift operators must maintain visual contact with the ground guide at all times. Serious injury or death could occur if the ground guide is pinned between the forklift and the pallet or FPU container.

3. Adjust forklift tines to fit forklift pockets on the ASLMS module.
4. With the assistance of a ground guide, insert tines into module. Stop with about 12-inches between the ASLMS module and the forklift bridge. This will allow for the clearance needed between the forklift bridge and the container frame when loading the module, to prevent the bridge from making contact with the container frame.
5. Using ground guide, lift module and position feet directly above the receptacles located on the floor adapter plate at the desired module storage position.
6. Lower the module until it settles into its position (shifting the tines left/right as necessary to align properly).
7. Push the module-locking arm in completely.
8. Slowly back away from the module until the tines have completely cleared.
9. Verify that the red handle on the module-locking arm is pushed completely to its closed and locked position.



OPERATING MODULE AND ITS COMPONENTS (FPU-8 PARTS only)

ASLMS modules consist of a base of five drawers enclosed in a metal outer hull, a detachable basket on top, a restraint bar, and a vinyl weather protection cover.

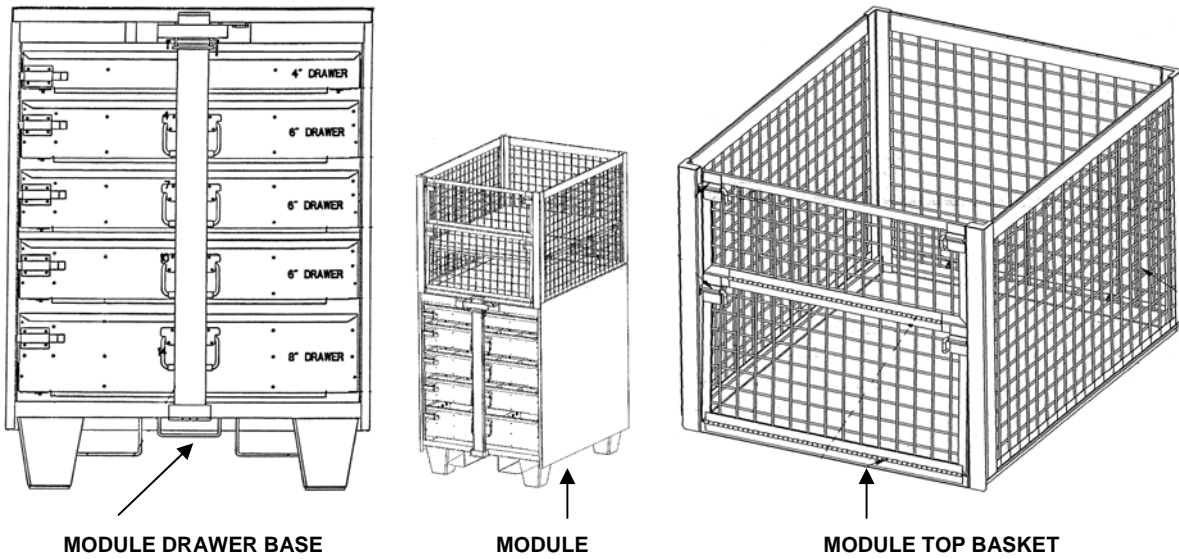

Opening and Closing Module Drawers



WARNING

Be cautious when opening drawers when the container is located on an incline. Failure to do so may result in injury.



WARNING

Container must be operated on level ground and periodically checked for shifting from a level position. Use care when opening drawers, as physical injury may occur. To maintain control, consider ground surface conditions that may not provide adequate traction, such as mud, snow, ice, sand. Seek assistance from fellow soldiers to prevent impact or strain injury.



WARNING

Keep hands, fingers and clothing clear of drawer assemblies when closing drawers. Failure to do so may cause injury.

CAUTION

Lubrication of drawer slam latches with approved lubricant is essential to ensure that drawers operate properly and fittings do not break off when drawer is slammed shut.

1. Remove 3-G bar and vinyl cover with hook and pile connectors.
2. While pulling the slam latch inward with left hand and holding in the open position, grasp the drawer ledge handle and pull firmly out.

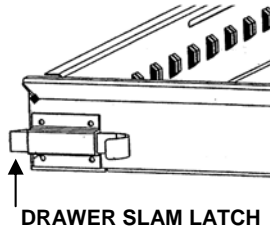

NOTE

Gloves are required when attempting to remove or install 4-inch drawer lid.

3. With drawer fully extended, manually activate the module drawer lock located at the rear of the drawer on each side.

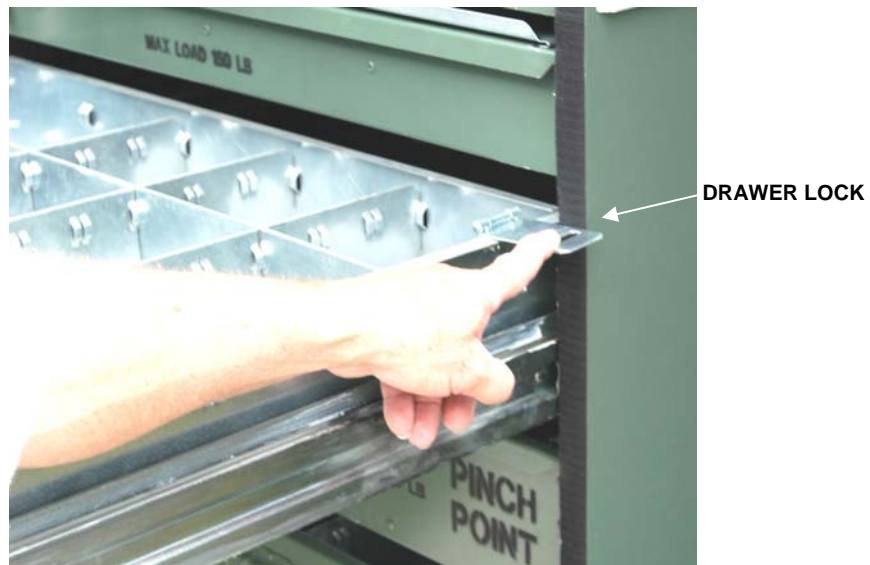

4. To close, unlock module drawer locks by folding completely inside the drawer.
5. Being careful to keep hands and fingers clear of the slides and completely on the front side of the drawer, firmly push drawer in until it slams shut.

Removing and Installing 4-inch Drawer Lid



WARNING

The 4-inch drawer lid may have sharp edges and pinch points that may cause lacerations, or tear fabric or equipment.

NOTE

Gloves are required when attempting to remove or install 4-inch drawer lid.

The 4-inch drawers installed on ASLMS modules have a removable lid that is designed to retain small material in assigned storage compartments.

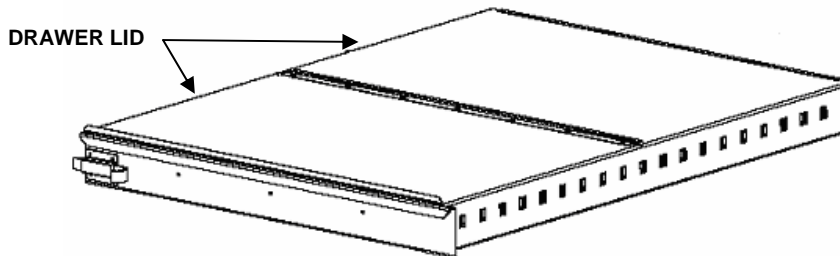

1. Extend drawer to its full open position.
2. Grasping the lid, slide outward to a distance so that hands can grasp both sides of lid beyond the hinge point.



3. Grasping both sides, remove lid by sliding outward until free of drawer.
4. Fold and store in a safe place.
5. To install, extend drawer to its full open position and lock.
6. Grasp the lid to the rear of the hinge point with both hands.
7. Align both sides of lid and drawer tracks and begin sliding inward.
8. As hands approach front of drawer release and grasp front of lid.
9. Continue to slide lid on to drawer being careful not to bind at the hinge joint.
10. Keeping fingers outboard of the lid and free of the cabinet hull, slide lid fully onto drawer.
11. Close drawer locks and push drawer inward to its closed position.

Attaching and Detaching Basket (Must be done with module removed from FPU)



WARNING

The baskets are heavy and awkward to handle by a single person. The adjustment of these items requires two or more persons to move or install - lift with legs, not back, to prevent injury. Failure to do so may result in serious back or other muscular skeletal injuries. Use gloves when removing or replacing drawers.

1. Remove the FPU-8 using procedures in this WP.
2. Attach the basket to the module by sliding it into the tracks on top of the module base.

- Secure the two tab locks located on the back of the basket. Ensure tabs swing behind lip of the module base.

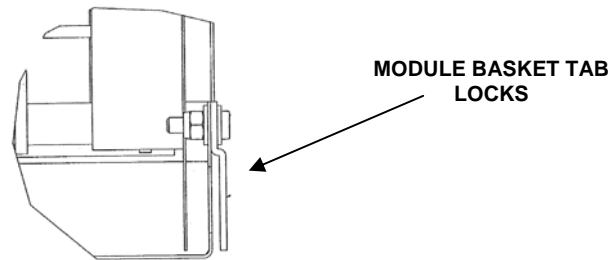

- Detaching is accomplished by rotating the two tabs up to clear the lip on the back of the module.
- Slide basket assembly off the module base. If loaded, use MHE.

NOTE

The 3-G bar secures the basket in place during shipment.

Opening and Closing Basket Door

- Remove all hook and pile connector straps from gate lock handles.
- Open the top door first. Rotate the gate lock handles on both sides directly outward.

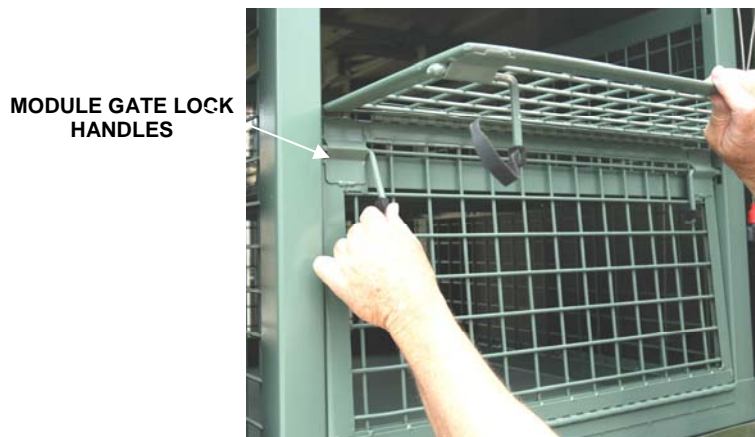

- Pull gate lock handles on the top door inward until completely free of lock receptacle. Always open top door first.
- Pull down to open.
- Open bottom door by first rotating the gate lock handle on both sides directly outward.
- Pull gate lock handles on the bottom door inward until completely free of lock receptacle.

7. Pull down to open.
8. To close the doors, first push up on the door.
9. Push gate lock handles outward.
10. Rotate the gate lock handles on both sides directly inward until locked.
11. Re-secure handles with the hook and pile connector straps.

Raising and Lowering the Basket Shelf Panels (Must be done with module removed from FPU)

The basket has user-adjustable split shelf panels with mounting tabs allowing for height adjustments. The split panels allow differing heights from front to back. The module must be removed to adjust shelves.

1. The basket shelf panels are secured by metal keepers that fit into slots on the mounting tabs and are retained in place with bolts and wing nuts through the shelf panels. Remove the wing nuts from the basket clamps of the front shelf.
2. Remove the basket clamps and slide front shelf panel up and out.
3. Using a ladder, remove the wing nuts from the basket clamps of the rear shelf.
4. Remove the basket clamps and slide rear shelf panel up and out.
5. Place the rear shelf in the desired position.
6. Using a ladder, reattach the basket clamps to the rear shelf and tighten.
7. Place the front shelf in the desired position.
8. Reattach the basket clamps to the front shelf and tighten.

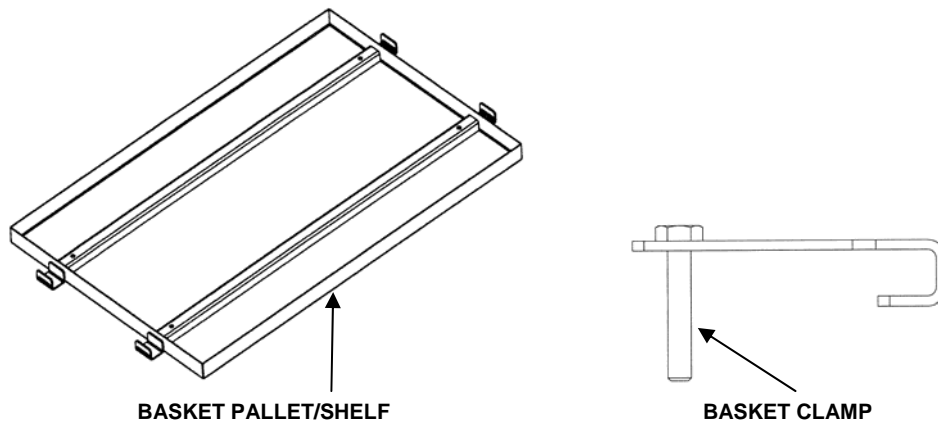

Vinyl Cover

The drawer base has a vinyl cover to protect the contents from dust/debris and is attached to the cabinet by hook and pile connectors.

1. After removal of the 3-G bar, pull the corner tabs to remove.
2. To replace, align and press into place.

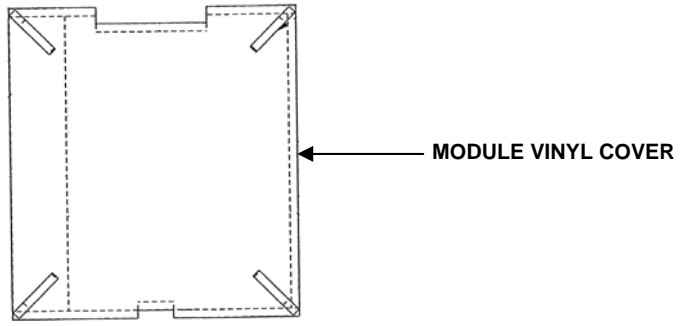

Removing ASLMS Module Drawers



WARNING

The drawers are heavy and awkward to handle by a single person. The adjustment of these items requires two or more persons to move or install. To further prevent injury, lift with the legs, not the back.

1. Fully extend and lock the drawer in open position. If the drawer will not stay in the open position, this task will require two people. One person should hold the drawer in the extended position while the other removes the drawer.
2. Remove all stored material from drawer.
3. Remove eight 1/4-inch screws located in the bottom of the drawer at either side.
4. Lift drawer from slide ledges.

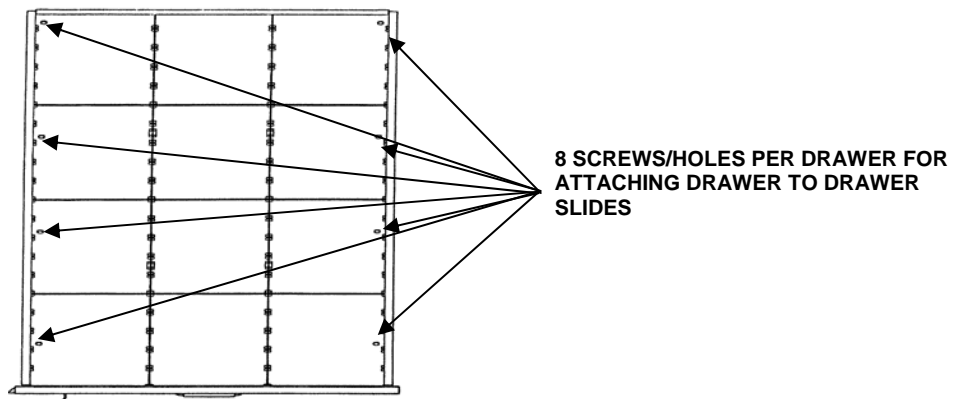

Installing ASLMS Module Drawers

1. Position the drawer on to the slide ledge, carefully aligning mounting holes.
2. Install eight 1/4-inch screws and lightly hand-tighten.
3. After hand-tightening and prior to full tightening of the eight 1/4 -inch mounting screws, push drawer completely closed and pull back to its full-extended position to allow the drawer to seat into its proper location on the drawer slide ledge. Check locking tab to be sure it will engage prior to final tightening.
4. Being careful not to over-tighten, secure the eight 1/4-inch mounting screws.

CAUTION

Be sure to install mounting screws in all eight positions. Failure to comply may result in damage to equipment.

END OF WORK PACKAGE

OPERATOR'S, UNIT, AND DIRECT SUPPORT MAINTENANCE

AUTHORIZED STOCKAGE LIST MOBILITY SYSTEM (ASLMS)

**MODEL NUMBER FPU-8/12 PARTS (OD) P/N 15005002-001
NSN 5411-01-523-2071**

**MODEL NUMBER FPU-8/12 PARTS (DS) P/N 15005002-002
NSN 5411-01-523-2072**

**MODEL NUMBER FPU-8/12 BULK (OD) P/N 15005001-001
NSN 5411-01-523-2073**

**MODEL NUMBER FPU-8/12 BULK (DS) P/N 15005001-002
NSN 5411-01-523-2074**

OPERATING ASLMS ELECTRICAL COMPONENTS

OPERATING ASLMS ELECTRICAL COMPONENTS

The following explains the electrical components contained in the ASLMS and how they work together. A functional description of the operation of these components and their related parts are covered in the following paragraphs.

In order to operate the ASLMS electrical components, two 150-ft power cables must be connected from a 20A outlet of a PDISE to the FPU-12 container distribution box located to the right of the bail bar. The PDISE is connected to a power generator or facility power. This connection provides A/C power to the 120VAC GFCI receptacles and the FPU-12 DC transformer. The FPU-12 DC transformer converts 120VAC power to 12VDC to power the overhead light fixtures inside of the containers. An auxiliary cable runs from the distribution box located at the rear of the FPU-12 to the distribution box located at the front of the FPU-8 to operate the FPU-8 lights. There are two 120VAC outlet connectors located on the distribution box on the rear of the FPU-8 that allows for the connection of additional ASLMS systems in a series. It is not recommended to connect more than two ASLMS systems in series.

A/C Main Components

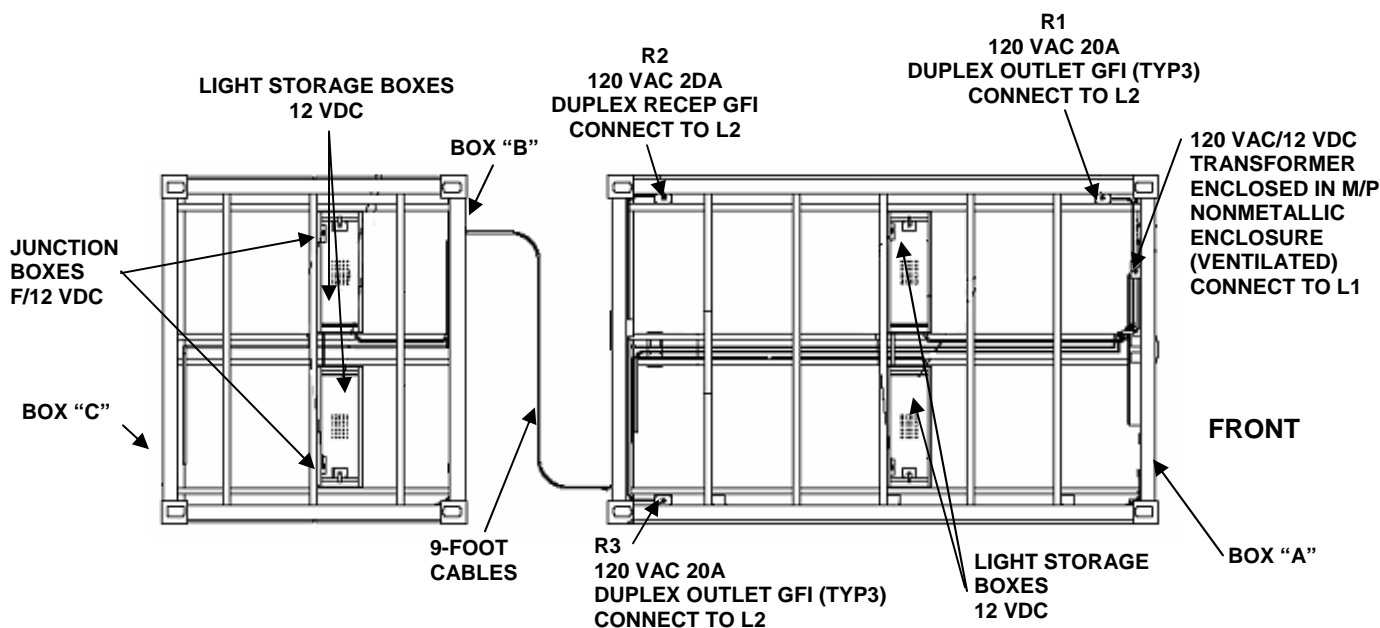

- FPU-12 - Receives power via two (2) 150-foot long A/C power cables from the PDISE and supplies A/C power to three 120 VAC Ground Fault Circuit Isolated (GFCI) power outlets and step down transformer.
- A/C Inlet Connector (FPU-12) - Provides for the connection of the A/C power cables bringing power into the container.
- A/C Outlet Connector (FPU-8) - Provides for the connection of the A/C power cables to send power to another container.
- Three 120 VAC, 20 AMP, GFCI, and outlets to power any electrical accessories as required.
- Two 150-foot A/C Power Cables - Power cables provide A/C Electric power from one stand alone ASLMS or another.
- Two 9-foot A/C Power Cables - Power cables provide A/C Electric power from the FPU-12 unit to the FPU-8 unit.

D/C Main Components

- One 120 VAC/12 VDC Transformer (FPU-12) - Receives A/C power and converts it to low voltage D/C power for the lighting fixtures.
- One 9-foot D/C Power Cord - Power cord provides D/C Electric from the FPU-12 unit to the FPU-8 unit.
- Four D/C powered red/white lighting fixtures – overhead light storage box, retractable fixtures providing both white lighting for normal operations and red lighting during blackout operations.

Connecting 9-Foot A/C and D/C Cables

1. Disconnect container from all power sources.
2. Connect cable marked “L1” to Distribution Box at Bail Bar end of FPU-12 being careful to attach to receptacle marked “L1”.
3. Repeat for cable marked “L2”.
4. Repeat for D/C Cable marked “D/C”.
5. Attach the other end of “L1,” “L2,” and “D/C” to the front side of Distribution Box of FPU-8 being careful to attach “L1” to “L1,” “L2” to “L2,” and “D/C” to “D/C”.

Connecting Two-150-Foot A/C Power Cables

1. Set circuit breakers at the PDISE to the OFF position.
2. Attach the two 150-foot cables to a 20A outlet at the PDISE.
3. Attach opposite ends to two receptacles located at the Distribution Box of FPU-12 Bail Bar end of the ASLMS.
4. Set the circuit breakers at the PDISE to the ON position.

Connecting & Disconnecting To PDISE



WARNING

Electrical power connections must be from a 20A outlet of a PDISE distribution panel. To prevent personnel injury, death, or equipment damage, electrical power must not be directly connected to the containers. Only trained and qualified personnel (MOS 51R, 52C, 52D or 52G) may perform maintenance or attempt to connect electrical discrepancies on the electrical system.

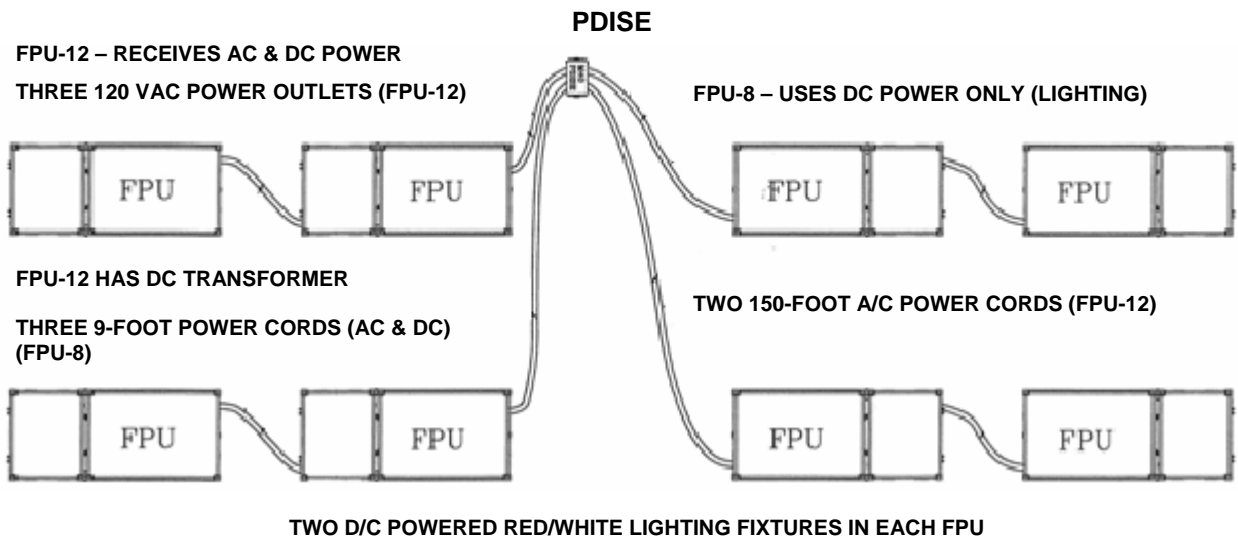
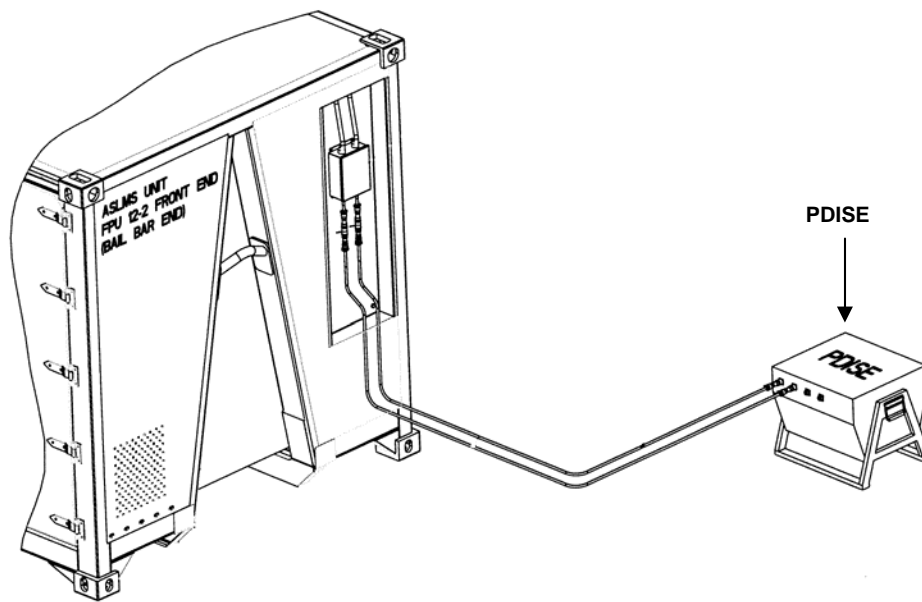



WARNING

To prevent electrical shock or damage to equipment, ensure all circuit breakers at the PDISE are set to the OFF position prior to connecting power cables to the ASLMS.

NOTE

It is recommended that the ASLMS containers be grounded (grounding rod and strap not provided) when in use. Ground lugs are located in the recessed areas at the front and rear of the containers. The ASLMS system will be grounded through the generator or facility power. Operator should ensure the power source is properly grounded.

1. Always connect both A/C and D/C connector cables to the rear of the FPU-12 (the side with step plates) and the front of the FPU-8 (the side w/o step plates) prior to connecting to the PDISE.

NOTE

This step will already be completed if containers are still connected.

2. Verify that the main breakers at the PDISE are set to the OFF position.
3. Connect the 150-foot power cables from the PDISE to the FPU-12 (bail bar side).
4. Set the main breakers to the ON position at the PDISE.

Setup of Overhead Lighting Fixture

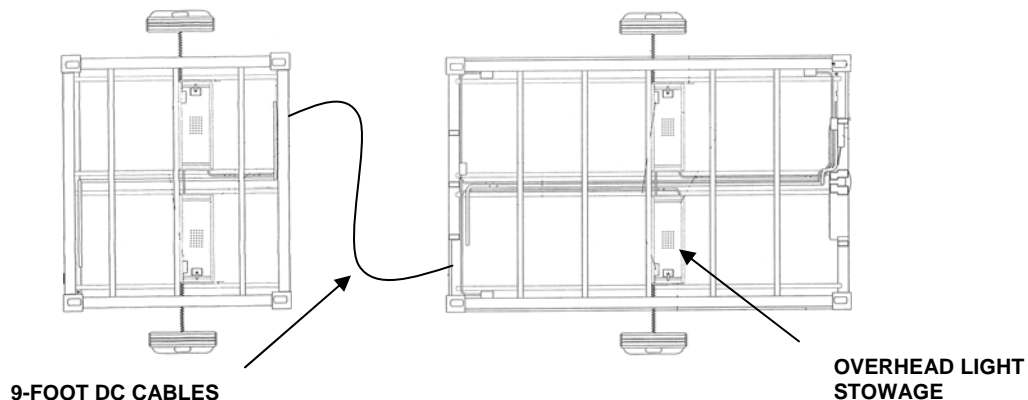

NOTE

EPC must be erected before proceeding.

1. With the ASLMS containers joined together, EPC erected and power connected, remove the four overhead lighting fixtures that are stowed inside the four compartments in the ceiling of the ASLMS container.

2. Remove the four 3-segment foldable light poles with mounting clips attached to the EPC frame pole storage brackets.
3. For access to lights, grasp turn handle and pull down on lighting stowage compartment door. The door will open revealing the lighting fixture with attached coiled power cord.
4. Remove the light and ensure the coiled cord fits the cutout in the door that is provided to prevent cutting the cord, when the door is closed.

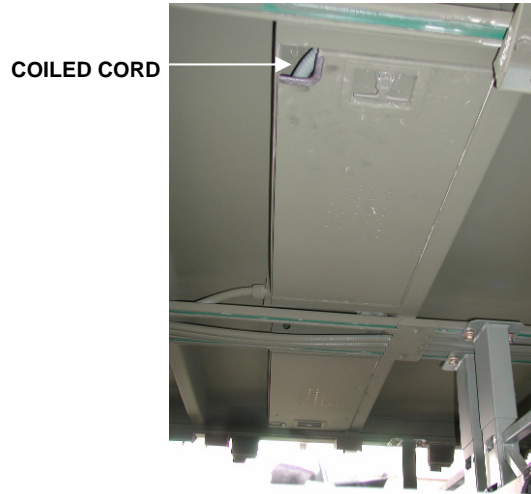

5. Place the light on the top of a pallet or drawer while assembling the pole structure.
6. Insert the two expandable light support poles into the clip with the wing nut just inside the doors on the track in the ceiling and insert and hang the other clip to the EPC door-to-door cross bar (pole assembly numbers 856, 885, 886, 895 or 896).

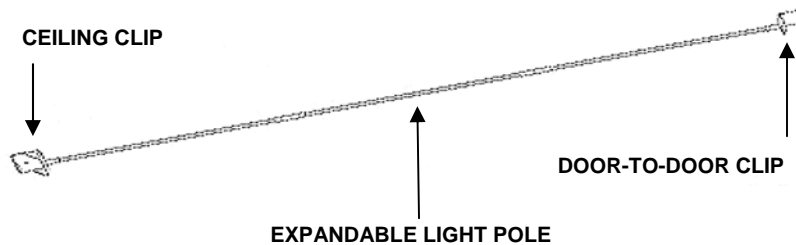

7. Secure the light support poles to support poles 883, 893, 884 and 894 using the hook and pile connector straps provided.

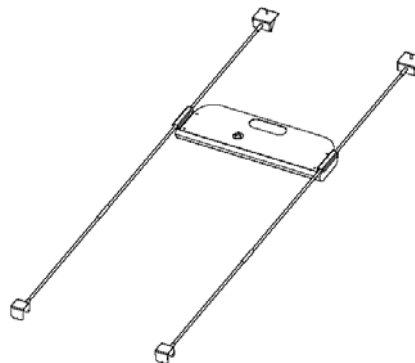

- Place the light on the expandable light poles supported by the hanger brackets on the light fixture.

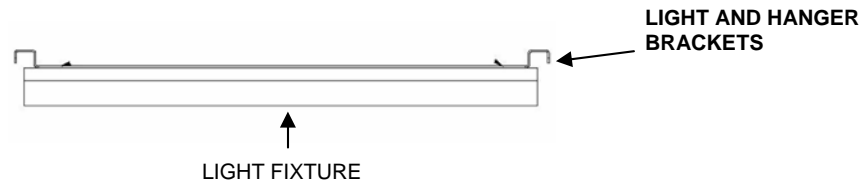

NOTE

Lights may be repositioned by sliding forwards/backwards and or sliding the pole clips side to side. Poles should align with the hanger brackets on the lights. Lights can also be used as a hand held system when needed.

- To operate the light, push switch to the ON position select red or white.

Replacement Light Tubes

- The standard fluorescent 24" light tubes are replaced by grasping the tube and rotating it a quarter turn to allow the contacts to align with the light fixture access slot for removal.

CAUTION

Do not force the fluorescent tube damage or injury may result.

- To replace the red lens slide the tube from the lens and replace by sliding the new replacement over the fluorescent tube.
- Install the replacement tube and/or lens by aligning the end contacts with the light fixture access slots, insert the tube and rotate the tube $\frac{1}{4}$ turn until secure.

END OF WORK PACKAGE

OPERATOR'S, UNIT AND DIRECT SUPPORT MAINTENANCE**AUTHORIZED STOCKAGE LIST MOBILITY SYSTEM (ASLMS)**

**MODEL NUMBER FPU-8/12 PARTS (OD) P/N 15005002-001
NSN 5411-01-523-2071**

**MODEL NUMBER FPU-8/12 PARTS (DS) P/N 15005002-002
NSN 5411-01-523-2072**

**MODEL NUMBER FPU-8/12 BULK (OD) P/N 15005001-001
NSN 5411-01-523-2073**

**MODEL NUMBER FPU-8/12 BULK (DS) P/N 15005001-002
NSN 5411-01-523-2074**

OPERATION OF THE ELEMENT PROTECTIVE COVER (EPC)

Element Protective Cover (EPC)

The EPC is a detachable fabric cover, stored inside the container, designed to provide protection from the elements and to serve as a light barrier during blackout operations. It is a one-piece cover that covers the entire container perimeter and provides a six foot base operating area on each side of the container. Tent stakes secure the sides and bottom corners of the cover. A multi-point adjustable strap system secures the ends of the cover to the container to ensure environment and light protection. Entrance/exit flaps provide access to stored material.

NOTE

When the EPC is erected on the FPU Bulk container and palletized material is retrieved or installed the EPC should be removed to access the pallet racks with MHE.

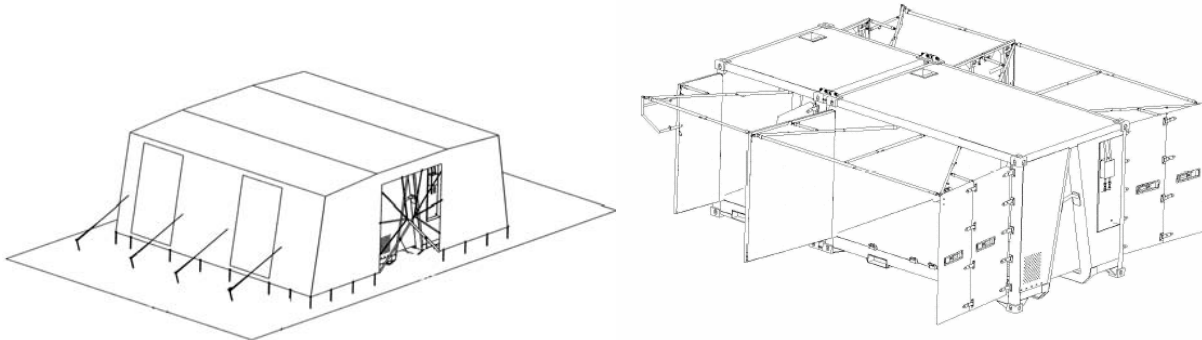
Setting up the EPC

1. Remove bridge locks (refer to WP 0005 00).
2. Open all ASLMS doors. Additional help may be required in windy conditions to hold doors in setup position (do not use door restraints during this operation).
3. **This step for ASLMS Parts containers only:** Remove linchpins and retainer pins from load constraint bar, located at the top of load constraint bar. Refer to WP 0006 00.
4. Remove load constraint bars and store.
5. Remove the EPC Bag from its stowed position on top of the pole storage area in the FPU-12 from lower front of the container floor.

**WARNING**

The EPC in the bag weighs approximately 177 lb. and requires six personnel using lifting handles to remove the bag from the storage area. Lift with the legs not the back to prevent injury. Failure to do so may result in serious back or other muscular or skeletal injury.

6. Remove the EPC frame pole storage bracket retention pins from the curbside and street side pole storage area.
7. Remove frame pole storage bracket by removing pins.

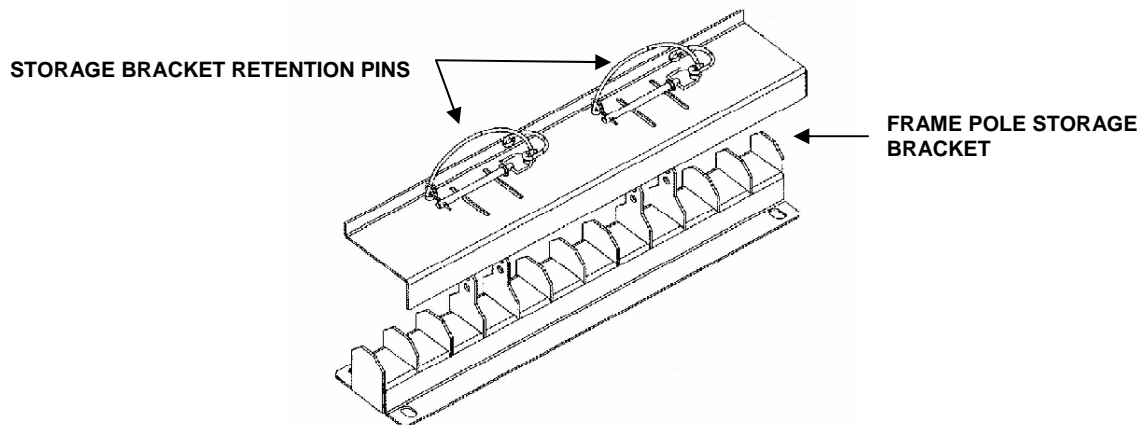

8. Remove EPC frame poles.

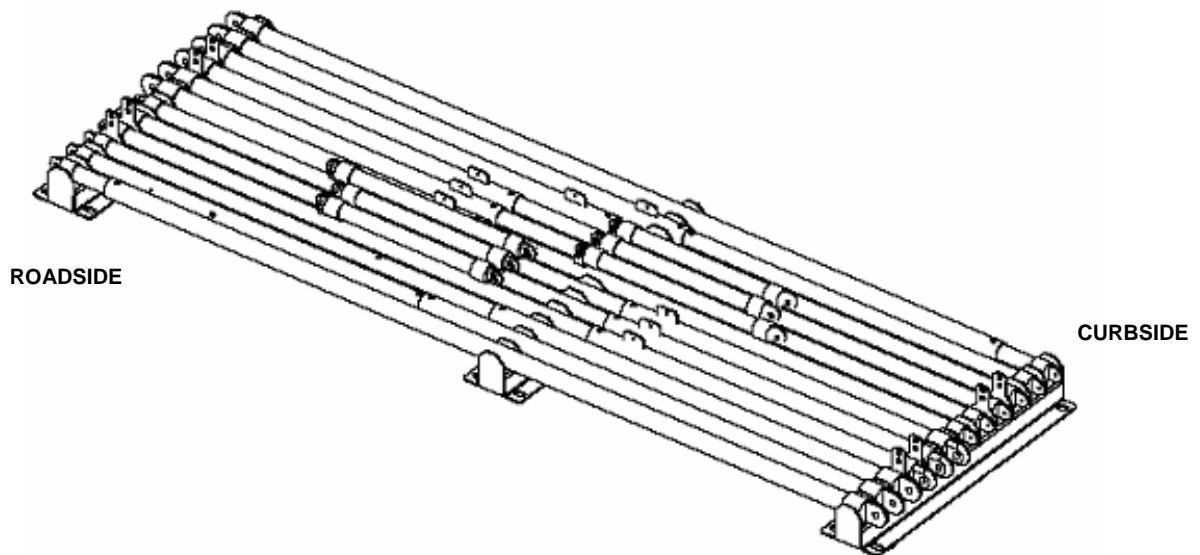

9. Reposition frame poles from stored position (yellow ring exposed) to deployed position (black ring exposed) by pulling the linchpin and retainer pin at center of pole, repositioning to the hole that aligns with the black ring and replacing the pin. After pinning in the deployed position, some poles will be longer and some shorter.
10. Remove pins securing the davits located on the rear doors of the FPU-8 (curbside and street side) and swing outward into their deployed position.



SECURING PINS



DAVIT



NOTE

Frame poles have various attaching points. Frame pole end caps are positioned to either hang or mount on top or bottom of an attachment point. The flat side of the end cap will always face the attachment point. Be sure to match the letter on the pole end with the letter on the container.

11. Install poles marked 883CS and 893SS. Attachment points are uni-strut located at the top inside of the FPU-8 door and the pin located at the top of the davit stabilizer strut on the FPU-8 door.

NOTE

EPC bracket located in the containers may require adjustment.

12. Install poles marked 882CS and 891SS. Attachment points are top of the davit and pin located at the top of the extended outer FPU-12 left door.

13. Install the two poles marked 881CS and the two poles marked 892SS. Attachments points are uni-strut located at the top left and right insides of the FPU-12 and door pins located at the top inside of each FPU-12 door. Small attachment head is mounted away from container.
14. Install poles 885CS and 895SS. Attachment points are at the ends of poles 881CS and 892SS.
15. Install poles 886CS and 896SS. Attachment points are at the ends of poles 883CS and 893SS and EPC bracket on the FPU-12 doors.
16. Install poles 884CS and 894SS. Attachment points are uni-strut located inside the center top of the FPU-12 and top of the center pin placement of poles 885CS and 895SS.

**WARNING**

Do not allow personnel to access the roof via forklift or other MHE.

17. With two personnel on the roof (via the steps at the FPU-8 end of the ASLMS) and using a forklift, place the EPC cover onto the roof of FPU-8.

NOTE

The Poles are numbered to match the Pole top view diagram below.

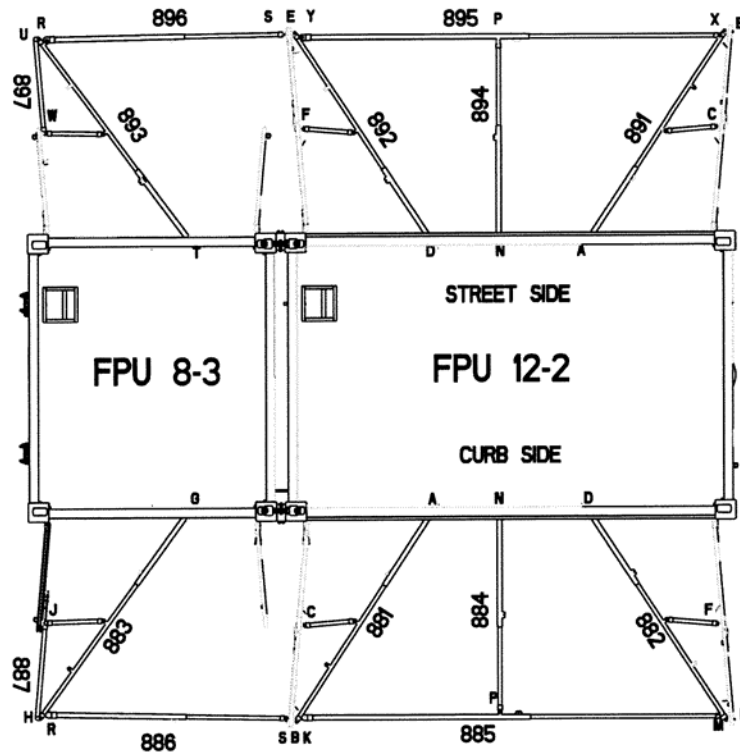

TOP VIEW

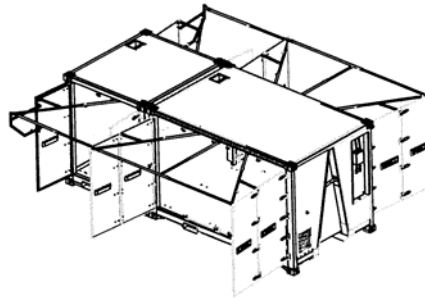

WARNING

Fall hazards that may cause injury or death exist when climbing onto, returning from or working from the top of the container. Always maintain three points of contact (two feet and one hand, or one hand and two feet) with the folding steps and roof access handle when climbing onto the ASLMS container. All movement should be in the forward direction. Never move, step, or walk backward when working on top of the system. A fall can occur if a worker loses concentration and steps backward off the edge. Stand erect only if necessary, and only away from the edge. Working from a kneeling position helps reduce the threat of a fall. Access to roof by forklift or other MHE is forbidden.

Beware of the ASLMS edge and the gap between the FPUs hidden under the EPC. Inadvertently stepping beyond the ASLMS edge or into this gap can cause serious injury. The EPC cover has a clearly marked roof safe-work area that defines the edges of the

container. When deploying or removing the EPC, stay within this defined area to prevent falling through the material in the pole support area.

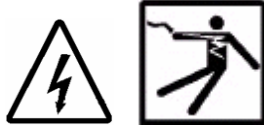

WARNING

Overhead power lines and obstructions can cause serious injury, death or damage to property. Forklift operators and truck drivers must utilize ground guides and always maintain clear overhead when loading, unloading, or moving the ASLMS containers.

18. Remove EPC cover, being careful to position the black arrow located on the EPC as follows:
 - a. EPC arrow is centered.
 - b. Arrow overhanging FPU-8 container.
 - c. Arrow pointing downward.

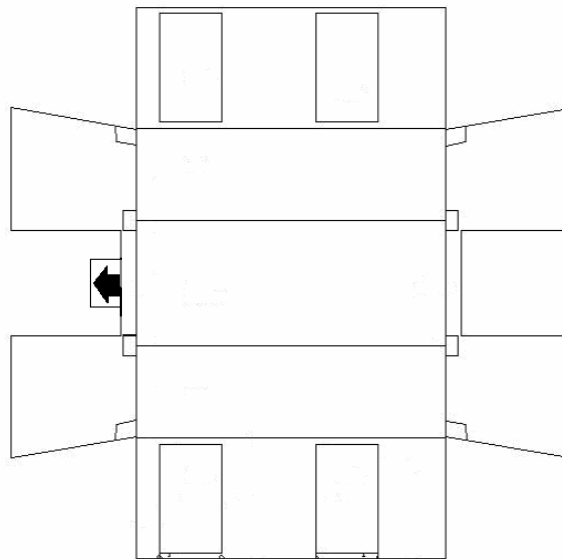

19. Unroll the EPC, by pushing it toward the FPU-12. Continue until completely unrolled.
20. Unfold the EPC along the container roof and drape the side panels over the edges of the container.
21. Align the inside reinforced areas of the EPC with the four top container corner blocks and corners of EPC frames.
22. Align the four outside reinforced corners over the top corner of the doors.
23. Remove bag containing EPC stakes, guy ropes, and hardware.



WARNING

Eye protection and gloves must be worn when driving stakes. Failure to comply may cause serious injury.

24. Stake the four outside corners of the EPC and area between door openings.

NOTE

The EPC cover is designed with an inner lip located completely around its bottom edges. In the event that conditions prevent the use of stakes, sand bags can be placed along these edges to secure EPC in place.

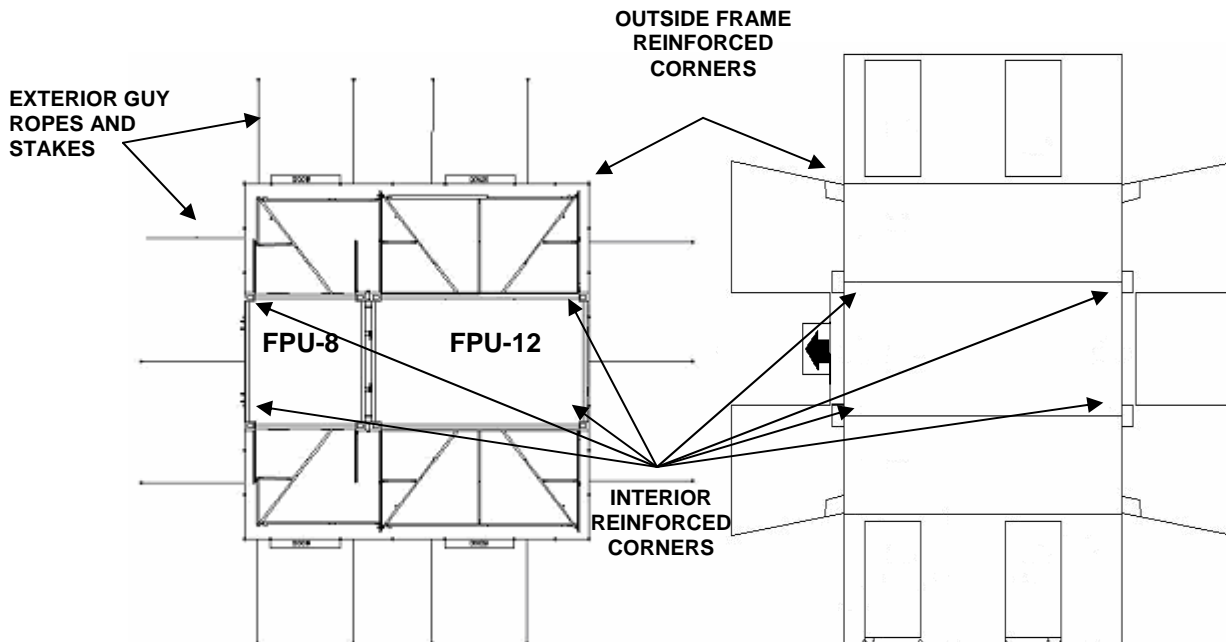

25. Set and secure exterior guy ropes and stakes.

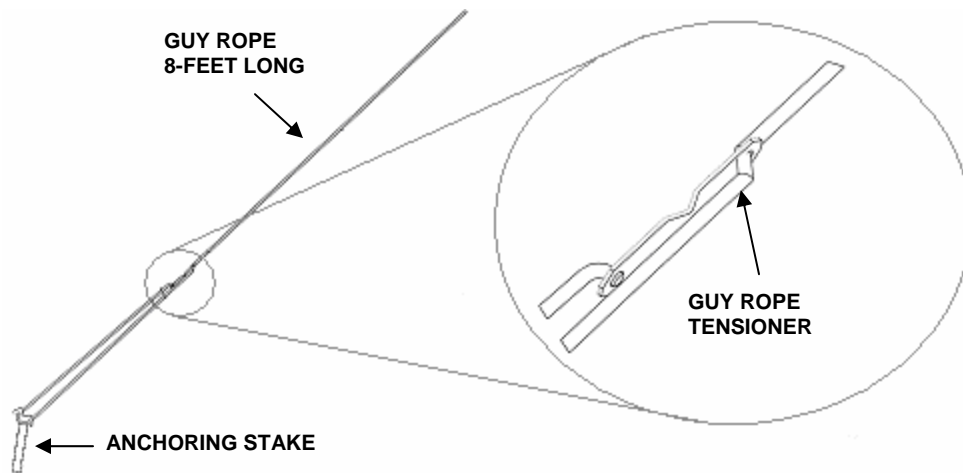

26. Install four tensioning straps on the open ends of the FPU-12 and FPU-8 as follows:

- a. Attach the single strap end of the harness to the bottom corner block on one side of the container.
- b. Attach the four straps of the harness to the clips on the straps affixed to the EPC cover located on the opposite side of the container.
- c. Tighten all straps as necessary.
- d. Install remaining stakes.

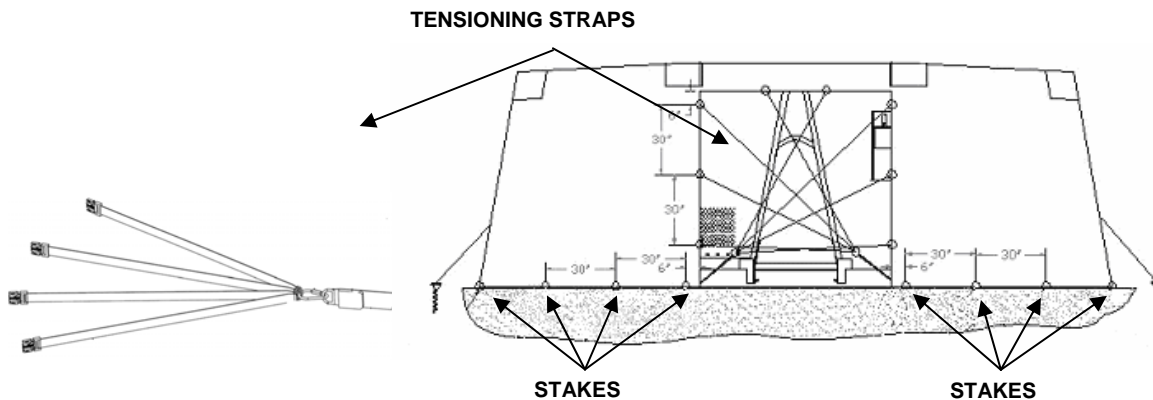

NOTE

Do not attempt to fold the EPC while on the roof of the container. This should be performed on clean level ground.

Storage of the EPC

1. Remove all stakes, straps, guy ropes and hardware and return them to the storage bag.
2. Remove the EPC cover from the top of the container and place it on the ground in a clear area that is large enough to lay the cover flat.

CAUTION

Ensure there are no protruding stumps, rocks, or other material that may damage the cover during the folding process.

3. Follow the folding procedure steps and illustrations below to properly fold and return the cover to the bag.
4. Place the cover on the ground in the following orientation.
5. Lay the cover out flat with the arrow tab pointing to your left.

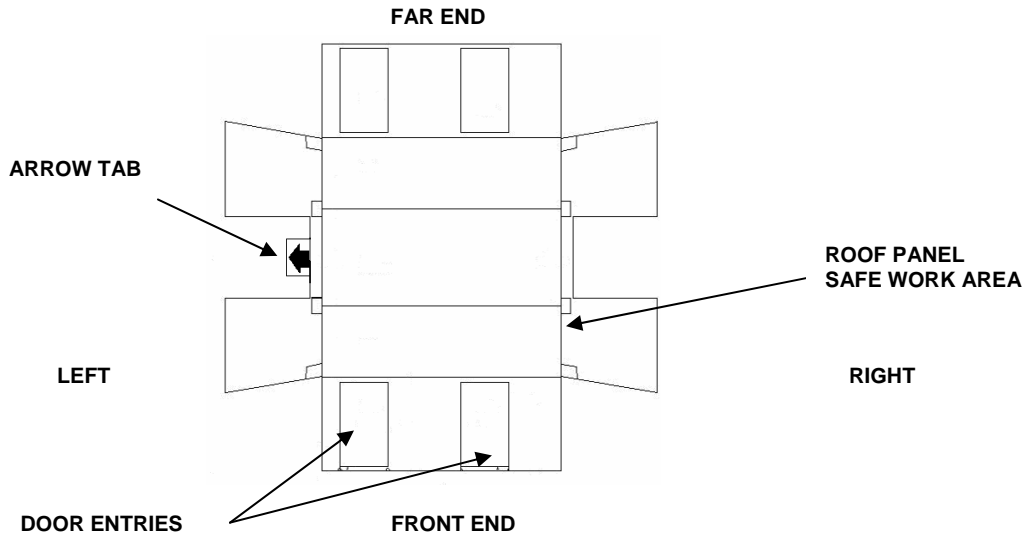

6. Go to the arrow tab side, grasp the left front and far end corners of the cover and fold toward the center of the cover. This should form an eight-sided octagon shape.



7. Ensure all straps are stored in toward the center of the cover.
8. Go to the right side grasp the right front and far end corners of the cover and fold toward the center of the cover.



9. Ensure all straps are stored in toward the center of the cover.
10. Grasp the left and right corners at the front door entries and fold toward the edge of the roof panel.



11. Grasp the right and left corners of this section and fold this in half toward the center of the cover.
12. Go to the far end of the cover and grasp the right and left corners at the door entries and fold toward the edge of the roof panel.



13. Grasp the far end of the corners and fold this section in half toward the center of the cover.



14. Come to the front end of the cover and grasp the right and left corners and fold this section in half.



15. Fold the front and far ends to the center of the roof panel to form a rectangle.



16. Fold this section in half (final fold) to form a long rectangle.



17. Pull out the securing belt and insure the arrow tab is flat and extended.

18. Roll the cover toward the arrow end from the right side.



19. Fasten the rolled cover with the securing belt and place the EPC in the bag.

20. Remove the poles from the container and store them in the floor storage brackets in the FPU 12.

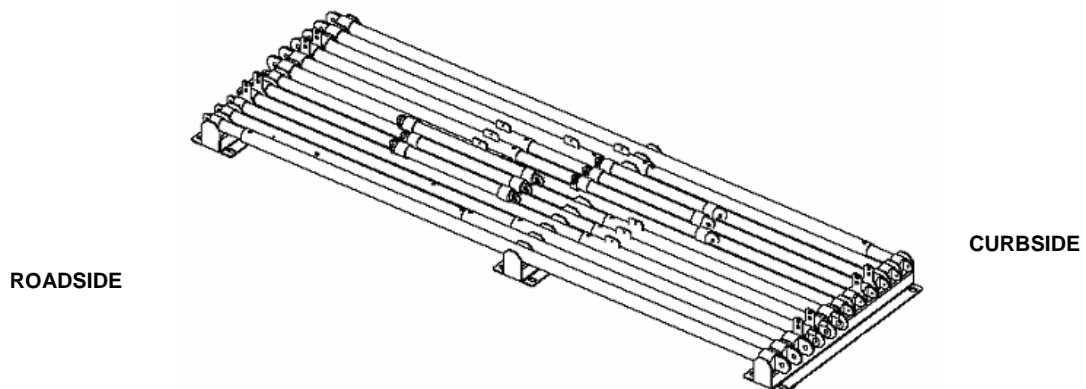

21. Secure the poles in the floor bracket with the storage bracket cap.

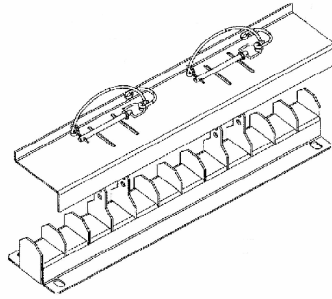

22. Place the EPC bag on the stored poles.



WARNING

The EPC in the bag weighs approximately 177 lb. and requires six personnel using lifting handles to remove the bag from the storage area. Lift with the legs, not the back, to prevent injury. Failure to do so may result in serious back or other muscular or skeletal injury.

23. Return and secure the davit supports to their storage position on the doors of the FPU-8.

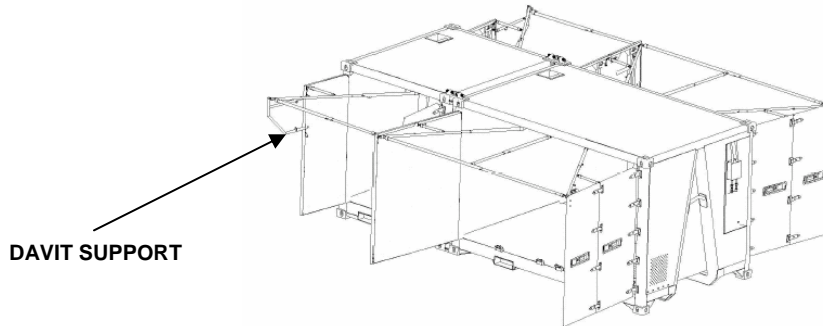

END OF WORK PACKAGE

OPERATOR'S, UNIT, AND DIRECT SUPPORT MAINTENANCE**AUTHORIZED STOCKAGE LIST MOBILITY SYSTEM (ASLMS)**

MODEL NUMBER FPU-8/12 PARTS (OD) P/N 15005002-001
NSN 5411-01-523-2071

MODEL NUMBER FPU-8/12 PARTS (DS) P/N 15005002-002
NSN 5411-01-523-2072

MODEL NUMBER FPU-8/12 BULK (OD) P/N 15005001-001
NSN 5411-01-523-2073

MODEL NUMBER FPU-8/12 BULK (DS) P/N 15005001-002
NSN 5411-01-523-2074

OPERATION UNDER UNUSUAL CONDITIONS**INITIAL SETUP:****Equipment Condition**

ASLMS downloaded and operating.

Maintenance Level

Operator/Crew

Personnel Required

Two (plus one supervisor).

OPERATION UNDER UNUSUAL CONDITIONS

This work package provides instructions for the operation of the ASLMS under unusual conditions. These include adverse weather, nuclear, biological and chemical attack, and emergency blackout conditions.

Operation in Rain and/or Mud

1. Provide an adequate drainage ditch to prevent standing water around the ASLMS.

**WARNING**

Ensure all electrical connections are away from standing water

2. Check container and EPC (if used) for leaks.
3. Check for water pooling on top of the EPC.
4. Ensure EPC stakes (if used) remain secure as ground loosens.
5. Secure all accessories and container during extremely harsh rain.

Operation in Hot Weather

1. Open EPC flaps (as allowed during blackout conditions) to allow heat around the ASLMS to escape.
2. Retract or remove EPC, as allowed during blackout conditions, to allow heat to escape.
3. Attach EPC during container use to provide shade for operator during extreme hot weather.

Operation in Snow, Ice, or Extreme Cold



WARNING

Protective gloves should be worn when handling extremely cold metal parts in below freezing temperatures. Failure to wear gloves may result in frostbite or cause skin to freeze to the metal upon contact. Flesh may tear when attempting to pull away from the metal.

NOTE

Fluorescent lights may be slow to light at very low temperatures.

1. Do not allow ice and snow to build up on the EPC. As necessary, remove any accumulation with a soft bristle brush, broom, or equivalent.
2. Remove ice and snow from the EPC before stowing.

Fording and Swimming

The ASLMS is not watertight. It should never be submerged in any depth of water or material damage may result. When mounted on a M1076 PLS trailer or HEMTT truck, hard-bottom water crossings no deeper than approximately two feet can be forded. When in doubt, refer to Unit Standard Operating Procedures.

Interim Nuclear, Biological, and Chemical (NBC) Decontamination Procedures



WARNING

The ASLMS is NOT designed to be operated in NBC contaminated Environments. Do not operate the ASLMS in NBC contaminated environments. If possible cease operation of the ALSMS prior to an NBC event and do the following:

- Remove and store the EPC in the ASLMS (refer to WP 0009 00).
- Reduce the ASLMS to the transportation configuration with ventilation and access doors closed.

External surfaces of the ASLMS FPU are CARC painted and can be decontaminated, however, whenever possible, avoid contamination of the internal areas of the ASLMS FPU. Decontaminate the exterior surfaces of the ASLMS in accordance with FM 3-5. Qualified NBC NCOs should check for residual contamination before opening the container. Remain in MOPP 4 posture when opening the doors and have the NBC NCO check for contamination on interior surfaces. If thorough decontamination is required, refer to NBC NCO and FM 3-5 for procedures.

When an NBC attack is expected, and time allows, the ASLMS should be packed for transport with ventilation devices secured per WP 0009 00 until the threat of attack is over. If an NBC attack occurs, the unit must be decontaminated before use in accordance with FM 3-5.

Jamming and Electronic Countermeasures

The ASLMS is not affected by jamming or electronic countermeasures.

Operation During Blackout Conditions

The ASLMS can be operated during blackout conditions, using the EPC and access flaps with red operational lighting.

1. Ensure the EPC access flaps are closed.
2. Place the 12 VDC lighting fixtures in the RED operational mode.

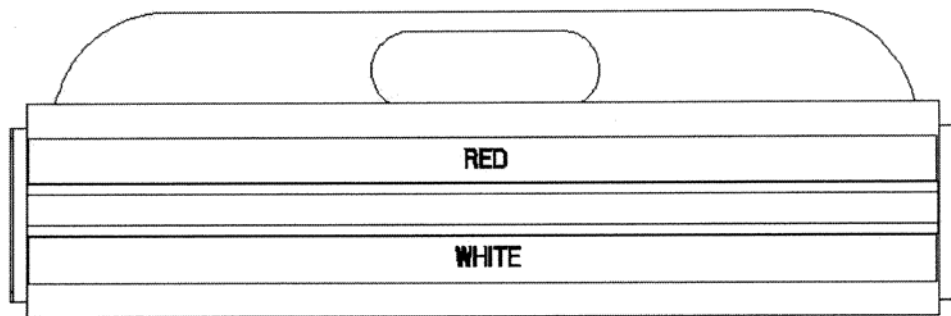

END OF WORK PACKAGE

CHAPTER 3
TROUBLESHOOTING PROCEDURES

OPERATOR AND UNIT MAINTENANCE**AUTHORIZED STOCKAGE LIST MOBILITY SYSTEM (ASLMS)**

**MODEL NUMBER FPU-8/12 PARTS (OD) P/N 15005002-001
NSN 5411-01-523-2071**

**MODEL NUMBER FPU-8/12 PARTS (DS) P/N 15005002-002
NSN 5411-01-523-2072**

**MODEL NUMBER FPU-8/12 BULK (OD) P/N 15005001-001
NSN 5411-01-523-2073**

**MODEL NUMBER FPU-8/12 BULK (DS) P/N 15005001-002
NSN 5411-01-523-2074**

INTRODUCTION

INTRODUCTION

The malfunction/symptom index in WP 0012 00 is a quick reference for finding the troubleshooting procedures. Associated with each symptom name is a table number representing the starting point in a troubleshooting sequence contained in WP 0013 00. The troubleshooting index is broken down by component. Find the component and malfunction/symptom, review the referenced table for the test or inspection and perform the corrective action. This type of activity continues until successful fault isolation is achieved.

Troubleshooting Procedures

The troubleshooting work package contains tables listing the malfunctions, checks or inspections, and corrective actions required to return the equipment to normal operation. Perform the steps in the order they appear in the tables.

The work package is headed by an initial setup. This setup outlines what is needed as well as the conditions that must be met before starting the task. **DO NOT START A TASK UNTIL:**

- You understand the task.
- You understand what you are to do.
- You understand what is needed to do the work.
- You have the things you need.

This manual cannot list all malfunctions that may occur, or all tests, inspections and corrective actions. If a malfunction is not listed or is not corrected by listed corrective actions, notify unit maintenance.

General Information

When troubleshooting the electrical system with power connected, place all switches and circuit breakers in the OFF position. Ensure all switches and circuit breakers are identified as "in work" to prevent accidental powering of equipment while servicing equipment in work. If any circuit breaker trips after it has been reset, notify unit maintenance.

END OF WORK PACKAGE

OPERATOR AND UNIT MAINTENANCE

AUTHORIZED STOCKAGE LIST MOBILITY SYSTEM (ASLMS)

- MODEL NUMBER FPU-8/12 PARTS (OD) P/N 15005002-001
NSN 5411-01-523-2071**
- MODEL NUMBER FPU-8/12 PARTS (DS) P/N 15005002-002
NSN 5411-01-523-2072**
- MODEL NUMBER FPU-8/12 BULK (OD) P/N 15005001-001
NSN 5411-01-523-2073**
- MODEL NUMBER FPU-8/12 BULK (DS) P/N 15005001-002
NSN 5411-01-523-2074**

TROUBLESHOOTING INDEXES

Table 1. Troubleshooting Index (Operator)

Malfunction/Symptom	Refer to WP 0013 00, Table 1, Procedure Number
Connecting/Disconnecting ASLMS	
Unable to Insert Horizontal Interconnectors into ISO Corner Blocks of FPU-12.	1
Unable to Insert Loading Rail Connector into FPU-12 Loading Rails.	2
Unable to install Transversal Stabilizer Cross Bar onto the Load Rail Connectors.	3
Unable to Retract Expandable End Tensioning Blocks.	4
Unable to Join FPU-8 to FPU-12.	5
Unable to Separate FPU-8/12 Containers.	6
Install/remove Rear Roller Assembly	
Unable to Install Rear Roller Assembly to FPU-8.	7
Installing the Fork Pocket Adapter Plug	
Unable to Install Fork Pocket Adapter Plug into FPU-8 Fork Pocket.	8
Securing ASLMS to PLS Trailer	
Unable to Insert the 1½-inch PLS Trailer Load Securing Pin.	9
Operating Ventilation System	
Filter Cover Plate Does Not Close.	10
Filter Cover Plate Will Not Lock into Open Position.	11
OPERATION OF ASLMS CONTAINERS	
Operation of ASLMS Doors	
Unable to Open Door	12
Unable to Close Door	13
Doors Leaking	14
Removing/Installing FPU-12 Parts Load Constraint Bars	
Unable to Install Load Constraint Bar.	15
Operating Adjustable Drawers (FPU-12 Parts only)	
Unable to Remove Drawer Slide Ledge Assembly from Vertical Rack Frame.	16
Unable to Install Drawer Slide Ledge Assembly onto Vertical Rack Frame.	17
Opening and Closing Drawers (FPU-12 only)	
Unable to Open Drawer.	18
Drawer Does Not Lock in the Fully Extended Position.	19
Unable to Close Drawer.	20

Table 1. Troubleshooting Index (Operator) (cont'd)

Pallet Rack System (FPU-12 Bulk, FPU-8 Bulk only)	
Unable to Insert a Pallet.	21
Unable to Remove a Pallet.	22
Adjusting Pallet Position	
Unable to Remove Pallet Ledge Assembly from Vertical Rack Frame.	23
Unable to Install Pallet Ledge Assembly onto Vertical Rack Frame.	24
Securing ASLMS Cargo Using Nets (2-inch Drawers and HAZMAT Pallets only)	
Male Parachute Clips on Nets Do Not Align with Female Clips on Drawer/Pallet.	25
Securing ASLMS Cargo Using Floor Nets (FPU-8/12 Bulk only)	
Safety Snaps Will Not Stretch Between Rings at Bottom of Vertical Rack Frames.	26
Securing ASLMS Cargo using Ratchet Straps	
Unable to Operate Ratchet Strap	27
OPERATION OF ASLMS MODULES	
Loading/Unloading ASLMS Modules	
Unable to Insert Module and Lock in Position	28
Unable to Remove Module	29
Operating Module and its Components (FPU-8 Parts only)	
Unable to Open Module Drawers	30
Unable to Close Module Drawers	31
Unable to Install Module Basket	32
Unable to Remove Module Basket	33
Unable to Open Module Basket Doors	34
Unable to Close Module Basket Doors	35
Unable to Remove Module Drawers	36
Unable to Install Module Drawers	37
OPERATION OF ASLMS ELECTRICAL COMPONENTS	
Connecting/Disconnecting to M40 PDISE	
Unable to Connect AC Power Cables	38
Unable to Connect DC 9-Foot Power Cables	39
Setup of Overhead Lighting Fixtures	
Light Does Not Operate	40
OPERATION OF ASLMS ACCESSORIES	
EPC	
EPC Frame Poles Do Not Fit Properly	41
EPC Cover Does Not Fit Properly	42
EPC Doors Misaligned	43
Tensioning Straps Do Not Fit Properly	44
Floor Adapter Plate	
Floor Adapter Plate Does Not Fit Smoothly to Floor	45

Table 2. Troubleshooting Index (Unit Maintenance)

Malfunction/Symptom	Refer to WP 0013 00, Table 2, Procedure Number
Connector Kit	
Containers Separate When Lifting	1
ELECTRICAL SYSTEMS	
A/C SYSTEM	
Interior Electrical Outlets	
No Power from the Outlets	2
D/C SYSTEM	
Lighting Fixtures	
None of the Lights Operate	3
Trailer Adapter	
Unable to Secure ASLMS to Trailer	4

END OF WORK PACKAGE

OPERATOR AND UNIT MAINTENANCE
AUTHORIZED STOCKAGE LIST MOBILITY SYSTEM (ASLMS)

**MODEL NUMBER FPU-8/12 PARTS (OD) P/N 15005002-001
NSN 5411-01-523-2071**

**MODEL NUMBER FPU-8/12 PARTS (DS) P/N 15005002-002
NSN 5411-01-523-2072**

**MODEL NUMBER FPU-8/12 BULK (OD) P/N 15005001-001
NSN 5411-01-523-2073**

**MODEL NUMBER FPU-8/12 BULK (DS) P/N 15005001-002
NSN 5411-01-523-2074**

TROUBLESHOOTING PROCEDURES

INITIAL SETUP:**Material/Parts**

None

References

None

Personnel Required

One

Equipment Condition

FPU set up.

Tools

General Mechanic's Tool Kit (Item 4, WP 0105 00)

NOTE

If malfunction corrective action does not correct the malfunction, notify unit maintenance.

Table 1. Operator Troubleshooting

Malfunction	Test or inspection	Corrective action required
1. Unable to Insert Horizontal Interconnectors into ISO Corner Blocks Of FPU-12.	Ensure jaws on corner horizontal interconnectors are fully open. Inspect for debris in ISO corner blocks.	Using appropriate BII tools, fully retract horizontal interconnector bolts. Clean as required. (Refer to WP 0005 00, 0037 00.)
2. Unable to Insert Loading Rail Connectors Into FPU-12 Loading Rails.	Inspect open end of loading rails on the FPU-12 for debris. Inspect for proper lubrication.	Clean as required. Lubricate (WP 0017 00) the loading rail connectors and open ends of loading rails as necessary. (Refer to WP 0005 00, 0037 00.)
3. Unable to Install Transversal Stabilizer Cross Bar on to the Loading Rail Connectors.	Inspect for Debris.	Clean as required. (Refer to WP 0037 00.)
4. Unable to Retract Expandable End Tensioning Blocks.	Inspect for Debris. Inspect for proper lubrication.	Clean as required. Lubricate (WP 0017 00) the tensioning block, tensioning bolt and jam nut as necessary.
5. Unable to Join FPU-8 to FPU-12.	Inspect open end of loading rails on the FPU-12 for debris. Inspect for proper lubrication.	Clean as required. Lubricate (WP 0017 00) the loading rail connectors and open ends of loading rails as necessary. (Refer to WP 0005 00, 0037 00.)

Table 1. Operator Troubleshooting (cont'd)

Malfunction	Test or inspection	Corrective action required
6. Unable to Separate FPU-8/12 Containers.	Check for cocked/twisted condition. Check to ensure horizontal interconnectors are fully retracted.	Push back into connected position, realign MHE and repeat disconnecting process. Retract horizontal interconnector adjuster bolt to the fully retracted position. (Refer to WP 0005 00.)
7. Unable to Install Rear Roller Assembly to FPU-8.	Inspect for debris on roller bracket saddle, rear support beam on the FPU-8 and roller pinning holes.	Clean as required. (Refer to WP 0005 00, 0036 00.)
8. Unable to Install Fork Pocket Adapter Plug into FPU-8 Fork Pocket.	Inspect for debris.	Clean as required. (Refer to WP 0005 00.)
9. Unable to Insert The 1 ½" PLS Trailer Load Securing Pin.	Inspect for debris. Ensure container is pushed all the way back until the both roller are touching the roller stops on the PLS trailer. Inspect the forklift adapter plug for proper orientation (right / left oriented).	Clean as required. Using HEMTT, push the container onto the trailer until both rollers make contact with the PLS trailer roller stops. Switch forklift adapter plugs as necessary. (Refer to WP 0005 00.)
10. Filter Cover Plate Does Not Close.	Inspect for debris or obstructions in filter track area. Inspect for debris in the filter cover plate retention mechanism. Inspect release cable to ensure it is not fouled.	Clean/clear as required. Clean as necessary. Clear as necessary. (Refer to WP 0047 00.)
11. Filter Cover Plate Will Not Lock into Open Position.	Inspect for debris in the filter cover plate retention mechanism.	Clean as necessary. (Refer to WP 0047 00.)
12. Unable to Open Door/Doors.	Inspect container position to ensure it is on level ground. Inspect door for misalignment. Inspect to determine if inner door handle is in the open position.	Relocate container to level ground. Align door/doors Close inner door and retry. (Refer to WP 0051 00.)
13. Unable to Close Door/Doors.	Inspect for debris in door threshold. Inspect outer doors to ensure they are in the closed position. Inspect door for misalignment. Inspect container position to ensure it is on level ground. Inspect to ensure door is being closed with proper seal orientation.	Clean debris from threshold. Close outer doors and retry. Align door/doors Relocate container to level ground. Retry with right door slightly ahead of the left to ensure proper seal orientation. (refer to WP 0051 00)

Table 1. Operator Troubleshooting (cont'd)

Malfunction	Test or inspection	Corrective action required
14. Doors Leaking	Inspect container door threshold for dirt, gravel or other obstructions. Inspect door seals for proper lubrication.	Clean as necessary. Lubricate (WP 0017 00) as required. (Refer to work package 0051 00.)
15. Unable to Install Load Constraint Bar.	Inspect for debris in the bottom load rail retainer boot.	Clean as necessary. (Refer to WP 0005 00, 0029 00.)
16. Unable to Remove Drawer Slide Ledge Assembly from Vertical Rack Frame.	Inspect to ensure all securing bolts have been removed. Check drawer ledge position to ensure it is clear of the vertical rack stanchion windows.	Remove bolts. Using 2X4 or similar object, tap upward on the drawer ledge until clear of vertical rack frame window. (Refer to WP 0006 00, 0030 00.)
17. Unable to Install Drawer Slide Ledge Assembly on the Vertical Rack Frame.	Inspect ledge tabs to ensure they are inside vertical rack frame windows.	Remove and reposition with all tabs inside vertical rack frame windows and tap downward with a 2X4 or similar object until bolt holes are aligned. (Refer to WP 0006 00, 0031 00.)
18. Unable to Open Drawer.	Inspect drawer locking handles to ensure they are in the unlocked position. Inspect for an obstruction inside the drawer.	Position drawer locking handles into the unlocked position and extend outward. Clear obstruction and open. (Refer to WP 0006 00, 0030 00.)
19. Drawer Does Not Lock in the Fully Extended Position.	Inspect drawer to ensure drawer is fully extended.	Pull back firmly on drawer to fully extend and turn locking handles to their locked position. (Refer to WP 0006 00, 0030 00.)
20. Unable to Close Drawer.	Inspect drawer locking handle to ensure they are in the open position. Check for an obstruction in the drawer.	Position handle in the open position and push inward. Clear/remove the obstruction. (Refer to WP 0006 00, 0030 00.)
21. Unable to Insert a Pallet.	Inspect pallet locking rod to ensure it is in the fully retracted position. Inspect pallet and pallet ledge area to ensure nets or straps on the pallet are not hung up on the pallet ledge.	Fully retract the pallet locking rod. Untangle net and straps and continue inserting pallet. (Refer to WP 0006 00.)
22. Unable to Remove a Pallet.	Inspect pallet locking rod to ensure it is in the fully retracted position. Inspect pallet and pallet ledge area to ensure nets or straps on the pallet are not hung up on the pallet ledge.	Fully retract the pallet locking rod. Untangle nets/straps and continue removing pallet. (Refer to WP 0006 00, 0032 00.)

Table 1. Operator Troubleshooting (cont'd)

Malfunction	Test or inspection	Corrective action required
23. Unable to Remove Pallet Ledge Assembly From Vertical Rack Frame.	Inspect to ensure all securing bolts have been removed. Check pallet ledge position to ensure it is clear of the vertical rack stanchion windows.	Remove bolts. Using 2X4 or similar object, tap upward on the drawer ledge until clear of vertical rack frame window. (Refer to WP 0006 00, 0033 00.)
24. Unable to Install Pallet Ledge Assembly onto Vertical Rack Frame.	Inspect pallet ledge tabs to ensure they are inside vertical rack frame windows.	Remove and reposition with all pallet ledge tabs inside vertical rack frame windows and tap downward with a 2X4 or similar object until bolt holes are aligned. (Refer to WP 0006 00, 0033 00.)
25. Male Parachute Clips on Nets Do Not Align with Female Clips on Drawer/Pallet.	Check the orientation of net to ensure it is proper fitted.	Turn net to orientate properly. (Refer to WP 0006 00.)
26. Safety Snaps on Floor Nets Will Not Stretch Between Rings at Bottom of Vertical Rack Frames.	Check orientation of net to ensure it is proper fitted.	Turn net to orientate properly. (Refer to WP 0006 00.)
27. Unable to Open Ratchet Strap Mechanism.	Check to ensure ratchet handle is in its full open position.	While pulling inward on the tension release bar completely straighten handle until tension is released. (Refer to WP 0006 00.)
28. Unable to Insert Module and Lock In Position.	Check module adapter plate cradles for debris. Check floor adapter plate cradles to ensure rubber pads are in place. Check module locking arm to ensure it is in the full open position.	Clean as necessary. Insert rubber pads as necessary. Check module locking arm for obstructions. Clear if necessary and fully extend outward to its full open position. (refer to WP 0007 00, 0035 00).
29. Unable to Remove Module.	Check module locking arm to ensure bit is in its full open position.	Extend module locking arm to its full open position. (refer to WP 0007 00)
30. Unable to Open Module Drawers.	Inspect for an obstruction inside the drawer. Visually inspect to ensure slam latch is being completely opened and is disengaging the lock striker.	Clear obstruction and open. Lubricate (WP 0017 00) if necessary and open slam lock until it disengages from lock striker and pull drawer outward. (refer to WP 0007 00)
31. Unable to Close Module Drawers.	Inspect for an obstruction inside the drawer. Visually inspect to ensure drawer locks are in their closed position.	Clear obstruction and open. Fold drawer locks completely into drawer and close. (refer to WP 0007 00)

Table 1. Operator Troubleshooting (cont'd)

Malfunction	Test or inspection	Corrective action required
32. Unable to Install Module Basket.	Inspect basket tab locks to ensure they are in the open position.	Swing tab locks upward to clear back of module and push basket completely inward until lock tabs can be position behind to lip on the back of module.
33. Unable to Remove Module Basket.	Inspect basket tab locks to ensure they are in the open position.	Swing tab locks upward to clear back of module and pull basket outward until completely clear of module basket track. (Refer to WP 0007 00.)
34. Unable to Open Module Basket Doors.	Check to ensure that both gate lock handles are completely free of the lock receptacles. Inspect to ensure cargo is not restraining doors.	Pull both gate lock handles inward until completely clear of the lock receptacle. Move cargo to free doors. (Refer to WP 0007 00.)
35. Unable to Close Module Basket Doors.	Inspect for an obstruction in the path of the basket gates. Check to ensure that basket gate locks are completely retracted.	Clear obstruction and close doors. Completely retract and close door. (Refer to WP 0007 00.)
36. Unable to Remove Module Drawers.	Visually inspect to ensure all eight ¼" mounting screws are removed.	Remove all remaining screws. (Refer to WP 0007 00.)
37. Unable to Install Module Drawers.	Visually inspect to ensure that all eight ledge nuts located on the drawer slides are installed.	Install ledge nuts as necessary. (Refer to WP 0007 00.)
38. Unable to Connect AC Power Cables	Check to ensure plugs are aligned with receptacle holes. Check for debris. Inspect to ensure the cord or receptacle is for AC power not DC power.	Rotate plug to align with mating receptacle and insert. Clean and insert. Connect to proper AC connection. (Refer to WP 0008 00.)
39. Unable to Connect DC 9-Foot Power Cables	Check to ensure plug s are aligned with receptacle holes. Check for debris. Inspect to ensure the cord or receptacle is for DC power not AC power.	Rotate plug to align with mating receptacle and insert. Clean and insert. Connect to proper DC connection. (refer to WP 0008 00)

Table 1. Operator Troubleshooting (cont'd)

Malfunction	Test or inspection	Corrective action required
40. Light Does Not Operate.	Visually inspect to ensure ASLMS is connected to PDISE and breakers are set to the on position. Visually inspect to ensure the two 150-foot power cables are connected to the ASLMS. Visually inspect to ensure the 9-foot DC power cable that joins the DC electrical from the FPU-12 to the FPU-8 is connected. Check to ensure the PDISE is connected to the power generator and the generator is operational.	Connect to PDISE and position the breakers to the on position. Connect the two 150-foot power cables to the FPU-12. Connect the DC power cable between the FPU-12 and FPU-8 containers. Coordinate with the generator operator to obtain a connection to the PDISE. (Refer to WP 0008 00, 0043 00.)
41. EPC Frame Poles Do Not Fit Properly.	Visually inspect to ensure EPC frame poles are in their deployed position. Check to ensure that the correct pole is being installed to its proper position.	Extend or retract the pole until the black rings are aligned and re-pin. Obtain proper pole number for the position being erected. (Refer to WP 0009 00.)
42. EPC Cover Does Not Fit Properly.	Check to ensure that the black arrow on the EPC cover is draped over and at the center of the FPU-8 container.	Reposition EPC cover to align the arrow on top off and at the end of the FPU-8 with the arrow hanging over and pointed downward. (Refer to WP 0009 00.)
43. EPC Doors Misaligned.	Check to ensure that the black arrow on the EPC cover is draped over and at the center of the FPU-8 container.	Reposition EPC cover to align the arrow on top off and at the end of the FPU-8 with the arrow hanging over and pointed downward. (Refer to WP 0009 00.)
44. Tensioning Straps Do Not Fit Properly.	Visually inspect to ensure that orientation of tensioning straps is proper for mating ends of EPC cover straps to connect.	Re-orientate and connect. (Refer to WP 0009 00.)
45. Floor Adapter Plate Does Not Fit Smoothly to Floor.	Inspect for debris under the floor adapter plate.	Clean as required and install. (Refer to WP 0006 00, 0034 00.)

Table 2. Unit Maintenance Troubleshooting

Malfunction	Test or inspection	Corrective action required
Connector Kit		
1. Containers Separate When Lifting	Both sides of Tandem-Loc correctly installed	Tighten Tandem-Loc locking bolts as required. (Refer to WP 0005 00.)
Electrical Systems		
A/C System		
Interior Electrical Outlets		
2. No Power from the GFCI Outlet	Check the GFCI reset button. Check the PDISE circuit breakers	Depress the GFCI reset button. Reset the PDISE circuit breakers. (Refer to WP 0008 00.)
D/C System		
Lighting Fixtures		
3. Lights Fail to Operate	Check the PDISE circuit breakers. Check all FPU 8/12 cable connections	Reset the PDISE circuit breakers (Refer to WP 0008 00.)
4 Florescent Light Fails	Check florescent tubes for proper installation and alignment with contacts	Replace florescent tubes. (Refer to WP 0055 00.)
Trailer Adapter		
5. Unable to Secure FPU to Trailer	Check Trailer Connection Adapter Plug for dirt/debris	Remove dirt/debris. (Refer to WP 0005 00.)
	Check for presence of Adapter Plug	Install Adapter Plug. (Refer to WP 0005 00.)

END OF WORK PACKAGE

CHAPTER 4
OPERATOR MAINTENANCE INSTRUCTIONS

OPERATOR MAINTENANCE
AUTHORIZED STOCKAGE LIST MOBILITY SYSTEM (ASLMS)

**MODEL NUMBER FPU-8/12 PARTS (OD) P/N 15005002-001
NSN 5411-01-523-2071**

**MODEL NUMBER FPU-8/12 PARTS (DS) P/N 15005002-002
NSN 5411-01-523-2072**

**MODEL NUMBER FPU-8/12 BULK (OD) P/N 15005001-001
NSN 5411-01-523-2073**

**MODEL NUMBER FPU-8/12 BULK (DS) P/N 15005001-002
NSN 5411-01-523-2074**

SERVICE UPON RECEIPT

INITIAL SETUP:**Material/Parts****References**

Personnel Required
One

WP 0002 00, WP 0005 00, WP 0067 00, SF 361,
DA PAM 738-750

Tools**Equipment Condition**

FPU packed-out.

SERVICE UPON RECEIPT

Upon receipt of the ASLMS or individual FPU containers, ensure all components are in proper working order. Note the following requirements.

Unpacking

The FPU containers are shipped with all components and equipment packed inside the ISO container. To unpack upon receipt, set up the FPUs as described in WP 0005 00 and inventory accessory items (WP 0002 00) as indicated below.

Inspection

Inspect the equipment for damage incurred during shipment. Report any damages on SF 361, Transportation Discrepancy Report.

Check the equipment against the Components of End Item and Basic Issue Items lists (WP 0103 00) to verify that the ASLMS is complete. Report any discrepancies in accordance with DA PAM 738-750.

END OF WORK PACKAGE

OPERATOR MAINTENANCE
AUTHORIZED STOCKAGE LIST MOBILITY SYSTEM (ASLMS)

**MODEL NUMBER FPU-8/12 PARTS (OD) P/N 15005002-001
NSN 5411-01-523-2071**

**MODEL NUMBER FPU-8/12 PARTS (DS) P/N 15005002-002
NSN 5411-01-523-2072**

**MODEL NUMBER FPU-8/12 BULK (OD) P/N 15005001-001
NSN 5411-01-523-2073**

**MODEL NUMBER FPU-8/12 BULK (DS) P/N 15005001-002
NSN 5411-01-523-2074**

PREVENTIVE MAINTENANCE CHECKS AND SERVICES (PMCS) INTRODUCTION

INITIAL SETUP:**Material/Parts****References**

None

Personnel Required

One

Equipment Condition

ASLMS set-up.

Tools

INTRODUCTION TO PREVENTIVE MAINTENANCE CHECKS & SERVICES (PMCS)

Preventive Maintenance Checks and Services (PMCS) are performed to keep the ASLMS containers in good operating condition. These checks aid in finding, correcting, or reporting problems. Operator personnel are to perform the PMCS tasks as shown in the PMCS table.

Do PMCS procedures each day the ASLMS is in operation, using the PMCS table in WP 0016 00. There are different intervals to perform PMCS procedures: before, during and after using the equipment, as well as weekly and monthly. Look at the table carefully to identify the required PMCS interval.

Perform all checks and services keeping in mind the following guidelines:

- Before you begin using the ASLMS, do **Before Operation PMCS**
- While the ASLMS is in use, do **During Operation PMCS**
- After using the ASLMS, do **After Operation PMCS**

If you find something wrong when performing PMCS, fix it using troubleshooting and/or maintenance procedures. Pay attention to WARNING and CAUTION statements. A **WARNING** means someone could be injured or killed. A **CAUTION** means equipment could be damaged.

The far right-hand column of the PMCS table lists conditions that make the ASLMS not fully mission capable. Write down the problem that cannot be repaired at your level on DA Form 2404 and forward for unit maintenance. For further information on how to use this form, see DA PAM 738-750.

If tools that are required to perform PMCS are not listed in the procedures, notify your supervisor.

Inspection

Look for signs of trouble. Use your senses to feel, smell, hear, or see problems that may exist. Inspect to see if items are in good condition. Are components correctly installed and secured? Is any damage to the frame or components visible? Correct any faults or notify Unit Maintenance.



WARNING

Although personnel authorized to operate ASLMS may connect electrical power from the PDISE to the FPU's, only personnel with MOS 51R, 52C, 52D, 52G or qualified civilian personnel may perform maintenance on the ASLMS electrical system. If ungrounded power is used, the ASLMS container must be electrically grounded to earth using an external grounding strap and rod (not furnished) connected to a grounding lug located at the power entrance of the FPU-12 or the exit panel of the FPU-8. Failure to ground the container may result in serious injury or death to personnel from electrical shock.

Associated Components

There are some common items to check on the ASLMS and associated equipment. These include the following:

- Proper operation of the interior lighting.
- Condition of the power cables.
- Condition and proper connection of ground strap and rod (if used).

Service

Proper service of the ASLMS and components is an integral part of maintenance. Regular cleaning prevents possible problems in the future, so make it a habit to clean the ASLMS and components whenever necessary.

END OF WORK PACKAGE

OPERATOR MAINTENANCE

AUTHORIZED STOCKAGE LIST MOBILITY SYSTEM (ASLMS)

**MODEL NUMBER FPU-8/12 PARTS (OD) P/N 15005002-001
NSN 5411-01-523-2071**

**MODEL NUMBER FPU-8/12 PARTS (DS) P/N 15005002-002
NSN 5411-01-523-2072**

**MODEL NUMBER FPU-8/12 BULK (OD) P/N 15005001-001
NSN 5411-01-523-2073**

**MODEL NUMBER FPU-8/12 BULK (DS) P/N 15005001-002
NSN 5411-01-523-2074**

PREVENTIVE MAINTENANCE CHECKS AND SERVICES (PMCS)

INITIAL SETUP:

Material/Parts

Rags (Item 8, WP 0105 00)
Water

References

None

Equipment Condition

ASLMS set-up.

Personnel Required

One

Tools

**Table 1. Preventive Maintenance Checks and Services for the ASLMS
PMCS B (Before), D (During), A (After), W (Weekly), M (Monthly)**

	B	D	A	W	M	Inspection Item and Procedure	Equipment Not Ready/Available If
1	*	*	*			Doors, Walls Check all doors and walls for cracks, dents, holes, or loose/missing hardware.	Missing doors, punctures, damage that would cause hazard or injury.
					*	Lubricate hinges, locks, as required.	
2	*	*	*	*		Exterior Check all exterior surfaces for cracks, dents that effect the operation of the ASLMS or its modules. Check for accumulations of dirt, debris, ice, snow, or salt. Clean as required.	Damage that would cause malfunction of the ASLMS working systems such as lock-downs or cause hazard or injury.
3	*	*	*	*		Interior Check floor for dirt and debris. Clean with broom or rags as required. Check module floor adapter plate in ASLMS floor for cracks or missing rubber pads. Schedule cracked cradles for repair. Check center ISO locks for cracks or missing items. Check locking levers for missing or loose cotter pins. Replace or tighten as necessary.	Two or more module cradles missing or damaged so that module does not seat. Center ISO locks that are broken or missing.
4	*	*	*		*	Data Plates Check plates for legibility, damage and/or missing. Clean with water and rag. Replace as needed.	

END OF WORK PACKAGE

OPERATOR MAINTENANCE**AUTHORIZED STOCKAGE LIST MOBILITY SYSTEM (ASLMS)**

**MODEL NUMBER FPU-8/12 PARTS (OD) P/N 15005002-001
NSN 5411-01-523-2071**

**MODEL NUMBER FPU-8/12 PARTS (DS) P/N 15005002-002
NSN 5411-01-523-2072**

**MODEL NUMBER FPU-8/12 BULK (OD) P/N 15005001-001
NSN 5411-01-523-2073**

**MODEL NUMBER FPU-8/12 BULK (DS) P/N 15005001-002
NSN 5411-01-523-2074**

CLEANING, LUBRICATING AND SPOT PAINTING

INITIAL SETUP:**Material/Parts**

Detergent (Item 1, WP 0105 00)
Rags (Item 8, WP 0105 00)
Water

References

TM 43-0139; TB 43-0242, WP 0013 00,
WP 0016 00, WP 0067 00

Personnel Required

One

Equipment Condition

ASLMS set-up.

Tools

CLEANING AND LUBRICATING

Cleaning and Lubricating of the FPU is performed to keep the FPU and its associated equipment in good operating condition. The cleaning and lubrication of the FPU can be conducted along with the Preventive Maintenance Checks and Services (PMCS) procedures described in WP 0016 00. Specific areas described below need to be cleaned after an operational event or periodically if stored/staged outside of a fixed facility to keep the container, modules, and accessories performing as designed. Cleaning also assists in maintaining the condition of the materiel stored within the system. Any damage discovered when cleaning and/or lubricating that cannot be corrected using the troubleshooting procedures described in WP 0013 00 should be reported for corrective maintenance.

SPOT PAINTING (CARC) OR POLYURETHANE

In conjunction with PMCS, spot painting of minor scraps and scratches that penetrate the CARC (exterior and interior walls, doors and floor) or the polyurethane painted surfaces (interior components) will be operator maintenance. Operator should refer to TM 43-0139, "Painting Instructions for Army Materiel" and TB 43-0242, "CARC Spot Painting", for instructions on preparing the surface, paint preparation and safety and health precautions. Expendable items for spot painting are listed in WP 0105 00.

Table 1. Cleaning

SURFACE	OIL/GREASE	SALT/MUD/DIRT DEBRIS	RUST/CORROSION
Exterior and Interior Walls (All)	Detergent, Water, Rags	Soapy Water, Brush, Rags	Corrosion Removal Compound and Wire Brush, Dry Rag, Coat with Lube Oil or Spot Paint
EPC Cover, ASLMS Module Cover, Nets	Detergent, Water, Rags	Soapy Water, Brush	N/A
Seals and Gaskets	Damp and Dry Rags	Damp and Dry Rags	N/A
Module Cradles, FPU Floor	Detergent, Water, Rags (Remove, clean, and replace rubber pad into footing)	Soapy Water, Brush, Rags (Remove, clean and replace rubber pad into footing)	Corrosion Removal Compound and Wire Brush, Dry Rags, Coat with Lube Oil or Spot Paint (Remove, clean, and replace rubber pad into footing)
Container Door Hinges, Module Glides, and Glide Out Tracks/Rollers	N/A	Brush, Rag and lubricate as needed to ensure rollers travel freely	Corrosion Removal Compound and Wire Brush, Dry Rags and Lubricate as needed
Generators, ECU and other Accessories	See the individuals operator's manual for each piece of equipment	See the individuals operator's manual for each piece of equipment	See the individuals operator's manual for each piece of equipment

Table 2. Lubrication

USAGE	FLUID or LUBRICANT	CAPACITIES	EXPECTED TEMPERATURES	INTERVAL
Door Hinges	General Purpose Lubricating Oil 10W	As Required	All Temperatures	Monthly or as required if under adverse conditions
Door Cam Locks	Molykote Multipurpose Synthetic Grease P/N 26040124	As Required	All Temperatures	Monthly or as required if under adverse conditions
Door Seals	Molykote Multipurpose Synthetic Grease P/N 26040124	As Required	All Temperatures	Monthly or as required if under adverse conditions
Door Lock Shaft Pivot Bearing	Molykote Multipurpose Synthetic Grease P/N 26040124	As Required	All Temperatures	Monthly or as required if under adverse conditions
Folding Steps	General Purpose Lubricating Oil 10W	As Required	All Temperatures	Monthly or as required if under adverse conditions

Table 2. Lubrication (cont'd)

USAGE	FLUID or LUBRICANT	CAPACITIES	EXPECTED TEMPERATURES	INTERVAL
Horizontal Inter-connectors	Molykote Multipurpose Synthetic Grease P/N 26040124	As Required	All Temperatures	Monthly or as required if under adverse conditions
Bridge Locks	Molykote Multipurpose Synthetic Grease P/N 26040124	As Required	All Temperatures	Annually or as required if under adverse conditions
Transverse Stabilizer Tensioning Blocks	Dry Film Lubricate P/N 26040123	As Required	All Temperatures	Bi-annually or as required if under adverse conditions
Transverse Stabilizer Tensioning Bolts	General Purpose Lubricating Oil 10W	As Required	All Temperatures	Bi-annually or as required if under adverse conditions
Loading Rail Connectors	Dry Film Lubricate P/N 26040123	As Required	All Temperatures	Each instance that the rails are removed and are to be re-installed
Open Ends of Loading Rails	Dry Film Lubricate P/N 26040123	As Required	All Temperatures	Monthly or as Required if Under adverse conditions
Filter Cover Plate retention Mechanism	Molykote Multipurpose Synthetic Grease P/N 26040124	As Required	All Temperatures	Monthly or as required if under adverse conditions
Filter Cover Plate Cable Pulley	General Purpose Lubricating Oil 10W	As Required	All Temperatures	Monthly or as required if under adverse conditions
Filter Retaining Lid Latches	General Purpose Lubricating Oil 10W	As Required	All Temperatures	Monthly or as required if under adverse conditions
Light Storage Compartment Handle	General Purpose Lubricating Oil 10W	As Required	All Temperatures	Monthly or as required if under adverse conditions
Light Storage Compartment Hinge	General Purpose Lubricating Oil 10W	As Required	All Temperatures	Monthly or as required if under adverse conditions

Table 2. Lubrication (cont'd)

USAGE	FLUID or LUBRICANT	CAPACITIES	EXPECTED TEMPERATURES	INTERVAL
Vertical Rack Stanchion Recessed Rings	General Purpose Lubricating Oil 10W	As Required	All Temperatures	Monthly or as required if under adverse conditions
Pallet Ledge Rear Cam Lock	General Purpose Lubricating Oil 10W	As Required	All Temperatures	Monthly or as required if under adverse conditions
Pallet Ledge Locking Rod	Molykote Multipurpose Synthetic Grease P/N 26040124	As Required	All Temperatures	Monthly or as required if under adverse conditions
Snap Hooks Safety Device on Ratchet Straps and Floor Nets	General Purpose Lubricating Oil 10W	As Required	All Temperatures	Monthly or as required if under adverse conditions
ASLMS Module Drawer Slides and FPU-12 Drawer Slides.	Molykote Multipurpose Synthetic Grease P/N 26040124	As Required	All Temperatures	Bi-annually or as required if under adverse conditions
FPU-12 Drawer Locking Mechanism shafts	General Purpose Lubricating Oil 10W	As Required	All Temperatures	Monthly or as Required if under Adverse Conditions
FPU-12 Drawer Locking Mechanism Tabs	Molykote Multipurpose Synthetic Grease P/N 26040124	As Required	All Temperatures	Monthly or as Required if under Adverse Conditions
ASLMS Module Drawer Slam Locks	Molykote Multipurpose Synthetic Grease P/N 26040124	As Required	All Temperatures	Monthly or as Required if under Adverse Conditions
ASLMS 4-inch Module Drawer Cover Track	Dry Film Lubricate P/N 26040123	As Required	All Temperatures	Bi-annually or as Required if under Adverse Conditions
ASLMS 4-inch Module Drawer Cover Hinge	General Purpose Lubricating Oil 10W	As Required	All Temperatures	Monthly or as Required if under Adverse Conditions
ASLMS Module Basket Track	Dry Film Lubricate P/N 26040123	As Required	All Temperatures	Bi-annually or as Required if under Adverse Conditions

Table 2. Lubrication (cont'd)

USAGE	FLUID or LUBRICANT	CAPACITIES	EXPECTED TEMPERATURES	INTERVAL
ASLMS Module Basket Gate Locks	Molykote Multipurpose Synthetic Grease P/N 26040124	As Required	All Temperatures	Monthly or as required if under Adverse Conditions
ASLMS Module Basket Tab Locks	General Purpose Lubricating Oil 10W	As Required	All Temperatures	Bi-annually or as Required if under Adverse Conditions
ASLMS Module Basket Shelf Panel Retainer Wing Nuts	General Purpose Lubricating Oil 10W	As Required	All Temperatures	Bi-annually or as Required if under Adverse Conditions
Floor Adapter Plate Twist Lock	Molykote Multipurpose Synthetic Grease P/N 26040124	As Required	All Temperatures	Monthly or as Required if under Adverse Conditions
Floor Adapter Plate Locking Rod Pivot	Molykote Multipurpose Synthetic Grease P/N 26040124	As Required	All Temperatures	Monthly or as Required if under Adverse Conditions

END OF WORK PACKAGE

OPERATOR MAINTENANCE**AUTHORIZED STOCKAGE LIST MOBILITY SYSTEM (ASLMS)**

MODEL NUMBER FPU-8/12 PARTS (OD) P/N 15005002-001
NSN 5411-01-523-2071

MODEL NUMBER FPU-8/12 PARTS (DS) P/N 15005002-002
NSN 5411-01-523-2072

MODEL NUMBER FPU-8/12 BULK (OD) P/N 15005001-001
NSN 5411-01-523-2073

MODEL NUMBER FPU-8/12 BULK (DS) P/N 15005001-002
NSN 5411-01-523-2074

DOOR ASSEMBLY (FPU-12)**INSPECT****INITIAL SETUP:****Material/Parts****References**

WP 0006 00

Personnel Required

One

Equipment Condition

ASLMS set-up.

Tools

Ladder (Item 6, WP 0063 00)

INSPECT

1. Open and close left/right door assembly (follow steps outlined in WP 0006 00) to ensure proper operation and alignment.

**WARNING**

Container should be operated on level ground and periodically be checked for shifting from a level position. Use care when opening doors, physical injury may occur. To maintain control consider the ground surface conditions for adequate traction, such as mud, snow, ice, sand and seek assistance from fellow soldiers to prevent impact or strain injury.

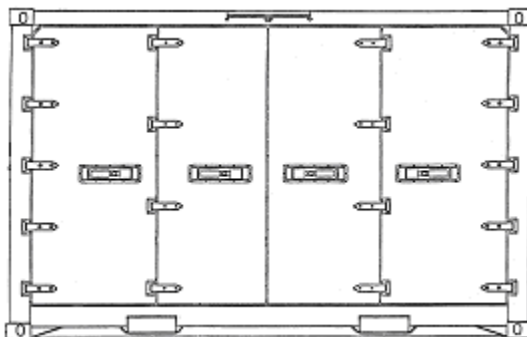

-
2. Notify unit maintenance of any missing or damaged seals and any problems with operation of latch, handle, or hinges for service.
 3. Notify unit maintenance of any problems with door alignment.

END OF WORK PACKAGE

OPERATOR MAINTENANCE

AUTHORIZED STOCKAGE LIST MOBILITY SYSTEM (ASLMS)

**MODEL NUMBER FPU-8/12 PARTS (OD) P/N 15005002-001
NSN 5411-01-523-2071**

**MODEL NUMBER FPU-8/12 PARTS (DS) P/N 15005002-002
NSN 5411-01-523-2072**

**MODEL NUMBER FPU-8/12 BULK (OD) P/N 15005001-001
NSN 5411-01-523-2073**

**MODEL NUMBER FPU-8/12 BULK (DS) P/N 15005001-002
NSN 5411-01-523-2074**

FOLDING STEPS

INSPECT

INITIAL SETUP:

Material/Parts

References

Personnel Required

Equipment Condition

One

ASLMS set-up.

Tools

INSPECT

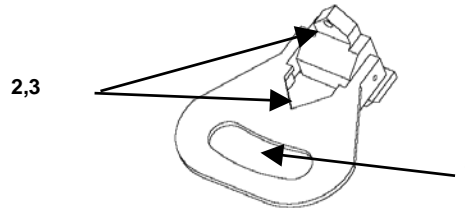
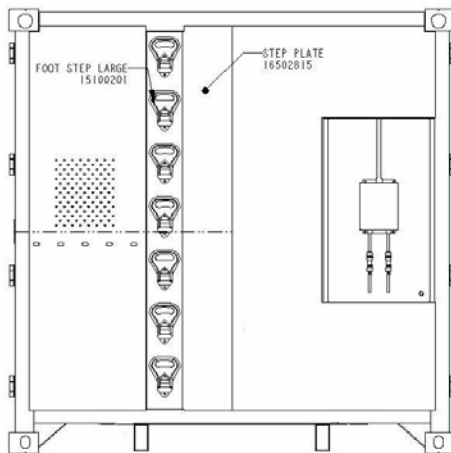

1. Raise and lower each of the steps (1) to ensure they stow and operate properly.
2. Notify unit maintenance of missing or broken or poorly operating steps (1).
3. Notify unit maintenance of any broken or missing hardware (2, 3).

END OF WORK PACKAGE

OPERATOR MAINTENANCE

AUTHORIZED STOCKAGE LIST MOBILITY SYSTEM (ASLMS)

**MODEL NUMBER FPU-8/12 PARTS (OD) P/N 15005002-001
NSN 5411-01-523-2071**

**MODEL NUMBER FPU-8/12 PARTS (DS) P/N 15005002-002
NSN 5411-01-523-2072**

**MODEL NUMBER FPU-8/12 BULK (OD) P/N 15005001-001
NSN 5411-01-523-2073**

**MODEL NUMBER FPU-8/12 BULK (DS) P/N 15005001-002
NSN 5411-01-523-2074**

VERTICAL RACK FRAME

INSPECT

INITIAL SETUP:

Material/Parts

References

Personnel Required

One

Equipment Condition

Door open, drawer and slides removed.

Tools

INSPECT

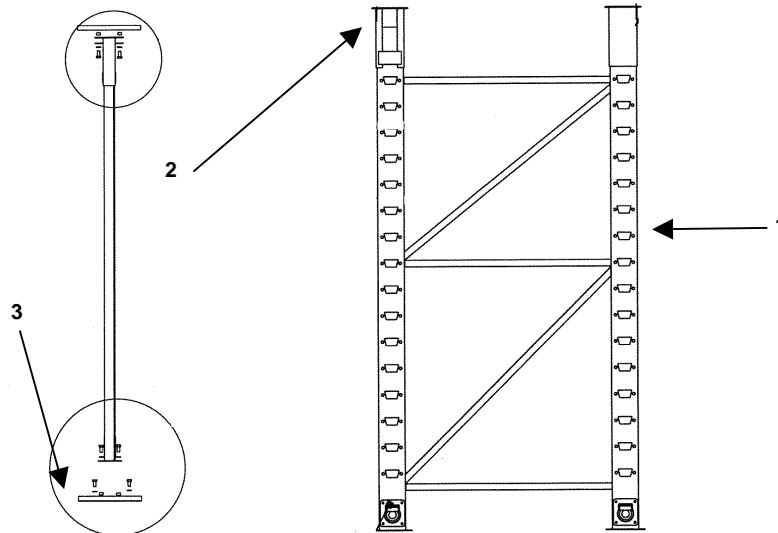

1. Inspect the vertical rack frame (1) for cracks, excessive dents or bending. Report to unit maintenance for repair or replacement.
2. Inspect vertical Rack upper attachment assembly (2) for cracks, excessive dents or bending. Report to unit maintenance for repair or replacement.
3. Inspect vertical rack frame for damaged or missing grip rivet nuts (3). Report to unit maintenance for repair or replacement.

END OF WORK PACKAGE

OPERATOR MAINTENANCE

AUTHORIZED STOCKAGE LIST MOBILITY SYSTEM (ASLMS)

MODEL NUMBER FPU-8/12 PARTS (OD) P/N 15005002-001
NSN 5411-01-523-2071

MODEL NUMBER FPU-8/12 PARTS (DS) P/N 15005002-002
NSN 5411-01-523-2072

MODEL NUMBER FPU-8/12 BULK (OD) P/N 15005001-001
NSN 5411-01-523-2073

MODEL NUMBER FPU-8/12 BULK (DS) P/N 15005001-002
NSN 5411-01-523-2074

CONSTRAINT BAR

INSPECT

INITIAL SETUP:

Material/Parts

References

Personnel Required

Equipment Condition

One

ASLMS set-up.

Tools

Ladder (Item 6, WP 0063 00)

INSPECT

1. Inspect the load constraint bars (1) for presence and proper fit.
2. Notify unit maintenance of missing bars and hardware.

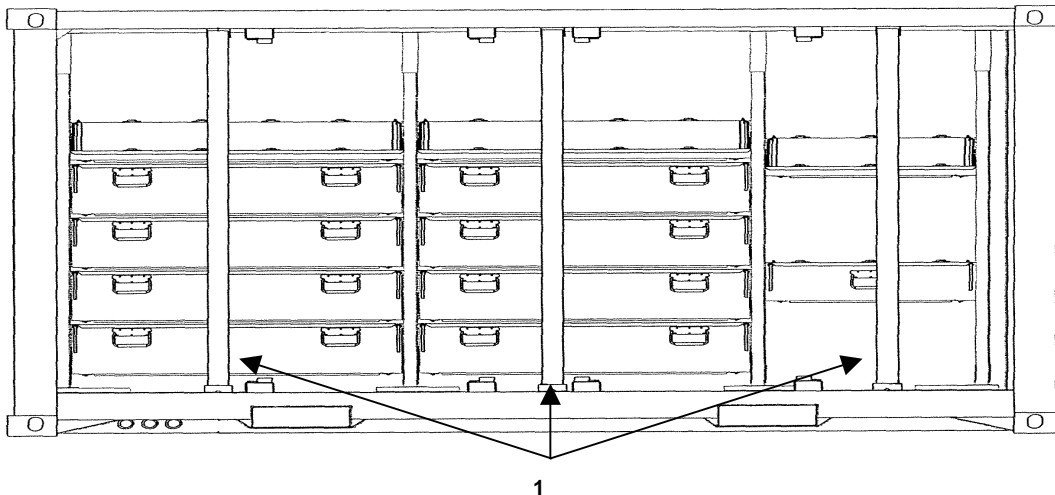

END OF WORK PACKAGE

OPERATOR MAINTENANCE

AUTHORIZED STOCKAGE LIST MOBILITY SYSTEM (ASLMS)

- MODEL NUMBER FPU-8/12 PARTS (OD) P/N 15005002-001
NSN 5411-01-523-2071
- MODEL NUMBER FPU-8/12 PARTS (DS) P/N 15005002-002
NSN 5411-01-523-2072
- MODEL NUMBER FPU-8/12 BULK (OD) P/N 15005001-001
NSN 5411-01-523-2073
- MODEL NUMBER FPU-8/12 BULK (DS) P/N 15005001-002
NSN 5411-01-523-2074

PALLET

INSPECT

INITIAL SETUP:

Material/Parts

References

Personnel Required

One

Equipment Condition

ASLMS set-up.

Tools

INSPECT

1. Inspect pallet (1) for cracks, excessive dents or sagging. Report to unit maintenance for repair or replacement.
2. Inspect pallet for missing or damage D-rings (2). Report to unit maintenance for repair or replacement.

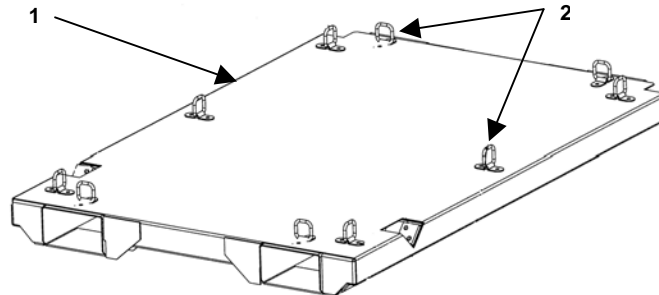

END OF WORK PACKAGE

OPERATOR MAINTENANCE**AUTHORIZED STOCKAGE LIST MOBILITY SYSTEM (ASLMS)**

**MODEL NUMBER FPU-8/12 PARTS (OD) P/N 15005002-001
NSN 5411-01-523-2071**

**MODEL NUMBER FPU-8/12 PARTS (DS) P/N 15005002-002
NSN 5411-01-523-2072**

**MODEL NUMBER FPU-8/12 BULK (OD) P/N 15005001-001
NSN 5411-01-523-2073**

**MODEL NUMBER FPU-8/12 BULK (DS) P/N 15005001-002
NSN 5411-01-523-2074**

PALLET LEDGE**INSPECT****INITIAL SETUP:****Material/Parts****References**

WP 0007 00

Personnel Required

One

Equipment Condition

ASLMS set-up.

Tools**INSPECT**

1. Remove pallet from container using a forklift (refer to WP 0007 00).
2. Inspect pallet FPU-12 ledges (1) for operation of cam locks (2), lock rods (3), and missing hardware per WP 0006 00.
3. Inspect pallet FPU-12 ledges for dirt/debris that would affect performance.

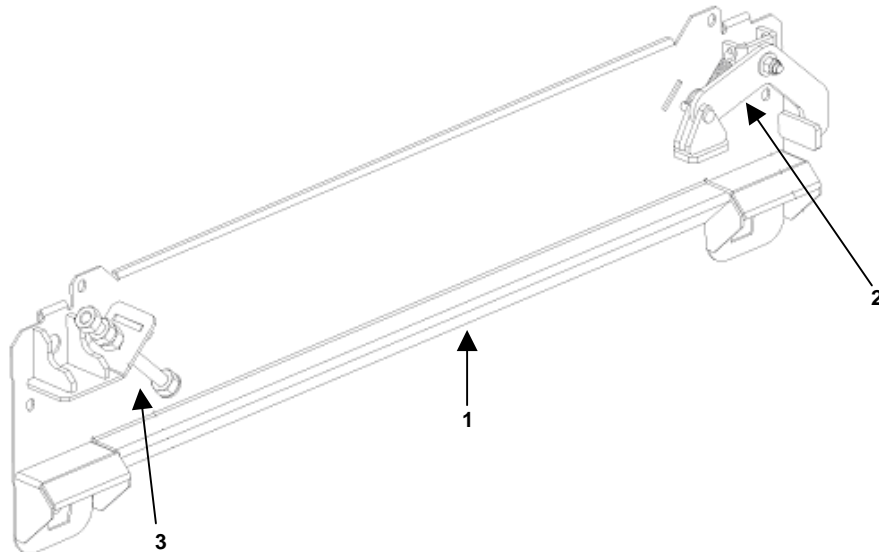
**END OF WORK PACKAGE**

OPERATOR MAINTENANCE**AUTHORIZED STOCKAGE LIST MOBILITY SYSTEM (ASLMS)**

**MODEL NUMBER FPU-8/12 PARTS (OD) P/N 15005002-001
NSN 5411-01-523-2071**

**MODEL NUMBER FPU-8/12 PARTS (DS) P/N 15005002-002
NSN 5411-01-523-2072**

**MODEL NUMBER FPU-8/12 BULK (OD) P/N 15005001-001
NSN 5411-01-523-2073**

**MODEL NUMBER FPU-8/12 BULK (DS) P/N 15005001-002
NSN 5411-01-523-2074**

DOOR ASSEMBLY (FPU-8)**INSPECT****INITIAL SETUP:****Material/Parts****References**

WP 0006 00

Personnel Required

One

Equipment Condition

ASLMS set-up.

Tools

Ladder (Item 6, WP 0063 00)

INSPECT**WARNING**

Container should be operated on level ground and periodically be checked for shifting from a level position. Use care when opening doors, physical injury may occur. To maintain control consider the ground surface conditions for adequate traction, such as mud, snow, ice, sand and seek assistance from fellow soldiers to prevent impact or strain injury.

1. Open and close left/right door assemblies (follow steps outlined in WP 0006 00) to ensure proper operation and alignment. (Left and right doors must be opened and closed at the same time.)
2. Notify unit maintenance of any missing or damaged seals and any problems with operation of latch, handle, hinges for service, or door alignment problems.
3. Notify unit maintenance of any problems with door alignment.

END OF WORK PACKAGE

OPERATOR MAINTENANCE**AUTHORIZED STOCKAGE LIST MOBILITY SYSTEM (ASLMS)**

**MODEL NUMBER FPU-8/12 PARTS (OD) P/N 15005002-001
NSN 5411-01-523-2071**

**MODEL NUMBER FPU-8/12 PARTS (DS) P/N 15005002-002
NSN 5411-01-523-2072**

**MODEL NUMBER FPU-8/12 BULK (OD) P/N 15005001-001
NSN 5411-01-523-2073**

**MODEL NUMBER FPU-8/12 BULK (DS) P/N 15005001-002
NSN 5411-01-523-2074**

ASLMS MODULE (FPU-8)

INSPECT

INITIAL SETUP:**Material/Parts****References**

WP 0007 00

Personnel Required

Two

Equipment Condition

ASLMS set-up.

Tools

INSPECT

1. Remove modules (1) from FPU-8P using a forklift (refer to WP 0007 00).
2. Inspect the module (1) for dirt/debris that would affect performance. Clean as required.
3. Inspect the module (1) for the presence of the locking bar (2) and retaining clip.
4. Ensure all drawers are held closed by slam latches (3).
5. Remove the locking bar (2).
6. Ensure the slam latch (3) on each drawer operates, allowing the drawer to open.
7. Ensure all drawers (4) can be fully extended and closed freely.
8. Ensure basket (5) (if attached) doors operate freely.
9. Ensure basket-locking tabs (6) (if attached) are in the down and locked position.
10. Ensure the vinyl cover (7) is in place, reattach if required.

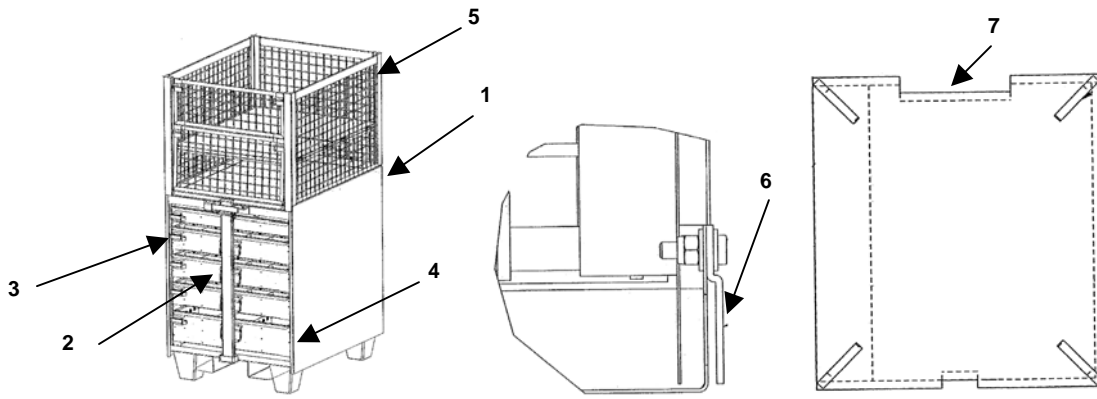

END OF WORK PACKAGE

CHAPTER 5
UNIT MAINTENANCE INSTRUCTIONS

UNIT MAINTENANCE**AUTHORIZED STOCKAGE LIST MOBILITY SYSTEM (ASLMS)**

MODEL NUMBER FPU-8/12 PARTS (OD) P/N 15005002-001
 NSN 5411-01-523-2071
 MODEL NUMBER FPU-8/12 PARTS (DS) P/N 15005002-002
 NSN 5411-01-523-2072
 MODEL NUMBER FPU-8/12 BULK (OD) P/N 15005001-001
 NSN 5411-01-523-2073
 MODEL NUMBER FPU-8/12 BULK (DS) P/N 15005001-002
 NSN 5411-01-523-2074

DOOR ASSEMBLY (FPU-12)**INSPECT, SERVICE****INITIAL SETUP:****Material/Parts**

Oil, Lubricating (Item 6, WP 0105 00)
 Rags (Item 8, WP 0105 00)

Tools

General Mechanic's Tool Kit (Item 4, WP 0063 00)
 Ladder (Item 6, WP 0063 00)

References

WP 0017 00

Equipment Condition

Doors open.

INSPECT

With doors open, inspect seal surfaces, and report problems with door seal to direct support maintenance.

SERVICE

1. Wipe seal surfaces clean and apply a light coat of lubrication to seal mating surfaces.
2. Report gouges, cracks, rips, tears, etc. in door seal to direct support maintenance.

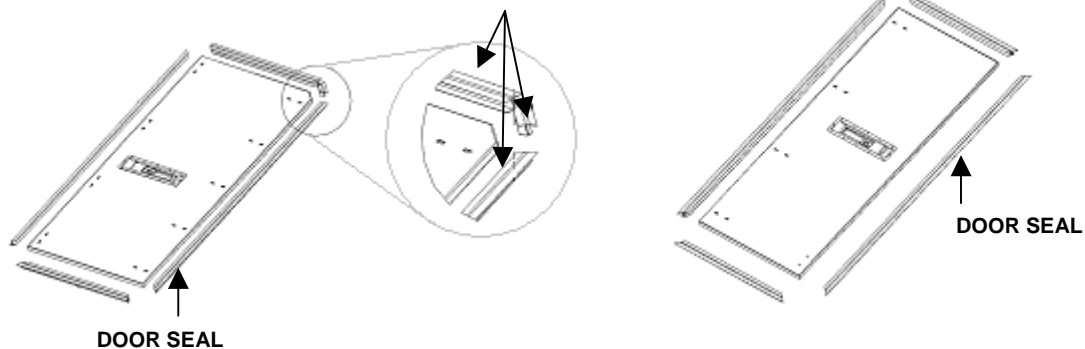
**END OF WORK PACKAGE**

UNIT MAINTENANCE

AUTHORIZED STOCKAGE LIST MOBILITY SYSTEM (ASLMS)

- MODEL NUMBER FPU-8/12 PARTS (OD) P/N 15005002-001
NSN 5411-01-523-2071
- MODEL NUMBER FPU-8/12 PARTS (DS) P/N 15005002-002
NSN 5411-01-523-2072
- MODEL NUMBER FPU-8/12 BULK (OD) P/N 15005001-001
NSN 5411-01-523-2073
- MODEL NUMBER FPU-8/12 BULK (DS) P/N 15005001-002
NSN 5411-01-523-2074

FOLDING STEPS

INSPECT, SERVICE, REPLACE

INITIAL SETUP:

Material/Parts

- Locktite 262 (Item 5, WP 0105 00)
- Oil, Lubricating (Item 6, WP 0105 00)

References

Equipment Condition

ASLMS set-up.

Personnel Required

Two

Tools

- General Mechanic's Tool Kit (Item 4, WP 0063 00)
- Ladder (Item 6, WP 0063 00)

INSPECT

Raise and lower each of the steps (1) to ensure they stow and operate properly.

SERVICE

Apply 10W lube oil between the moving parts.

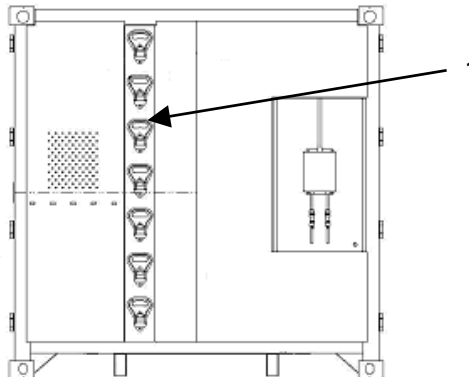

REPLACE

1. Remove modules/pallets/drawers as necessary to gain access to the step nuts (2).
2. With one person in the container and one person outside, remove the mounting bolts (3), washers and nuts with a 1/2-inch socket and a 1/2-inch open-end wrench.
3. Apply locktite to the step bolt threads feed bolts through the steps and the mounting holes on the container.
4. Apply sikaflex sealant to the area around the bolt (from the inside of the container) and install washers and nuts (4, 2).
5. Using a 1/2-inch socket and a 1/2-inch open-end wrench tighten nuts (2) and bolts (3).

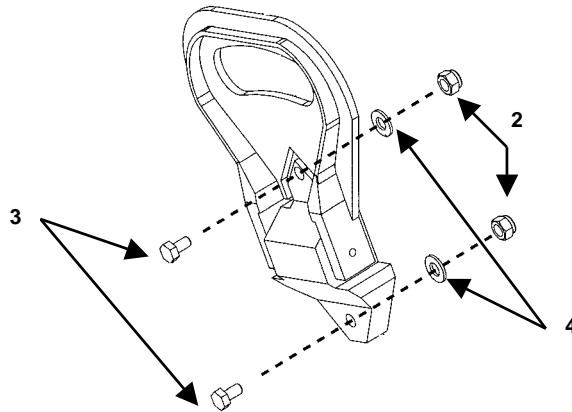
**END OF WORK PACKAGE**

UNIT MAINTENANCE**AUTHORIZED STOCKAGE LIST MOBILITY SYSTEM (ASLMS)**

**MODEL NUMBER FPU-8/12 PARTS (OD) P/N 15005002-001
NSN 5411-01-523-2071**

**MODEL NUMBER FPU-8/12 PARTS (DS) P/N 15005002-002
NSN 5411-01-523-2072**

**MODEL NUMBER FPU-8/12 BULK (OD) P/N 15005001-001
NSN 5411-01-523-2073**

**MODEL NUMBER FPU-8/12 BULK (DS) P/N 15005001-002
NSN 5411-01-523-2074**

VERTICAL RACK FRAME (FPU-12)**INSPECT, SERVICE****INITIAL SETUP:****Material/Parts**

Detergent (Item 1, WP 0105 00)

Rags (Item 8, WP 0105 00)

Water

Tools

General Mechanic's Tool Kit (Item 4, WP 0063 00)

Ladder (Item 6, WP 0063 00)

References**Personnel Required**

One

Equipment Condition

Doors open, drawers and slides removed.

INSPECT

1. Inspect the vertical rack frame (1) for cracks, excessive dents or bending. Report to direct support maintenance for repair or replacement.
2. Inspect vertical rack upper attachment assembly (2) for cracks, excessive dents or bending. Report to direct support maintenance for repair or replacement.
3. Inspect vertical rack frame for damaged or missing grip rivet nuts (3). Report to direct support maintenance for repair or replacement.

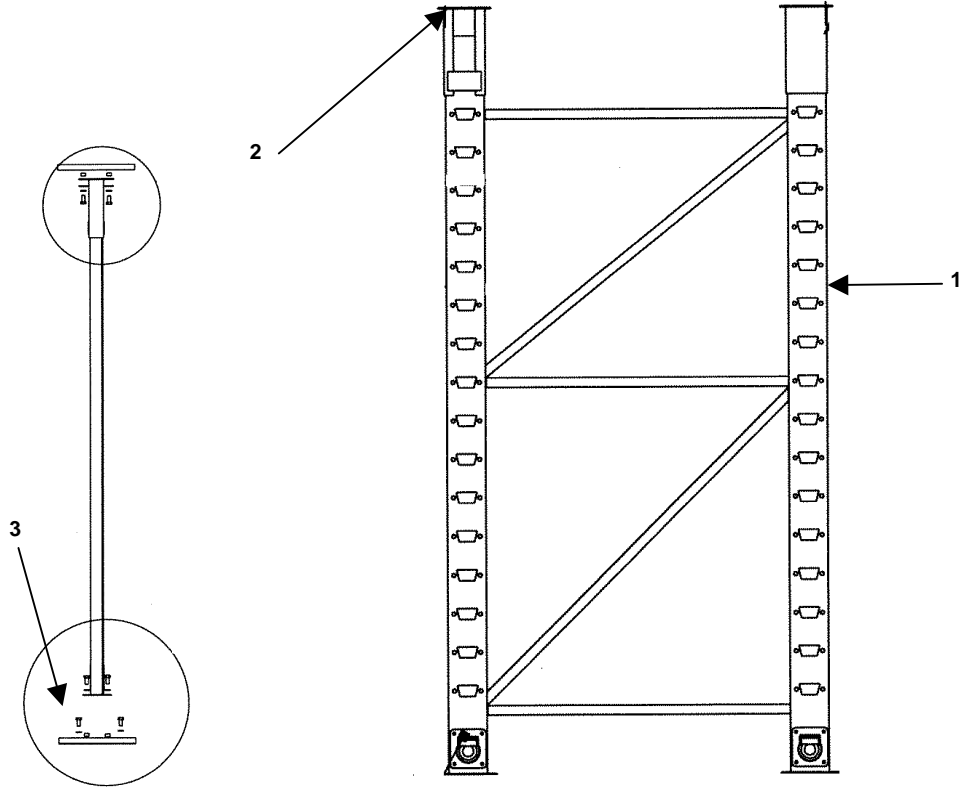

SERVICE

Wipe surfaces using a wet, soapy rag as necessary to keep equipment clean.

END OF WORK PACKAGE

UNIT MAINTENANCE

AUTHORIZED STOCKAGE LIST MOBILITY SYSTEM (ASLMS)

- MODEL NUMBER FPU-8/12 PARTS (OD) P/N 15005002-001
NSN 5411-01-523-2071
- MODEL NUMBER FPU-8/12 PARTS (DS) P/N 15005002-002
NSN 5411-01-523-2072
- MODEL NUMBER FPU-8/12 BULK (OD) P/N 15005001-001
NSN 5411-01-523-2073
- MODEL NUMBER FPU-8/12 BULK (DS) P/N 15005001-002
NSN 5411-01-523-2074

CONSTRAINT BAR (FPU-12)

INSPECT, REPLACE, REPAIR

INITIAL SETUP:

Material/Parts

References

Tools

- Drill (Item 2, WP 0063 00)
- Drill Bit, 3/16" (Item 3, WP 0063 00)
- Ladder (Item 6, WP 0063 00)

Personnel Required

One

Equipment Condition

Doors open.

INSPECT

Inspect the load constraint bars (1) for presence and proper fit.

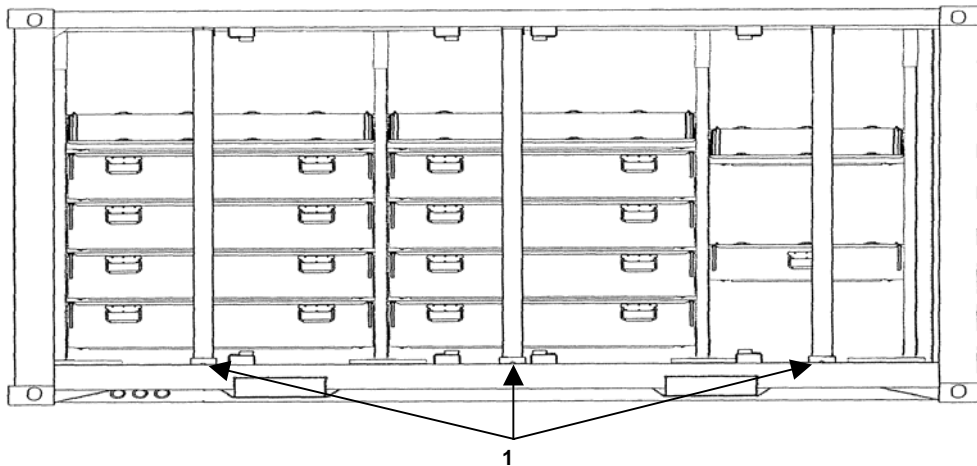

REPLACE

Replace hair pin (1) by feeding a new hair pin (1) onto the lanyard.

REPAIR

1. Using a 3/16" drill bit, drill out the old rivet (2) that attaches the constraint bar securing assembly.
2. Attach new securing assembly with a 3/16-inch closed-end rivets.

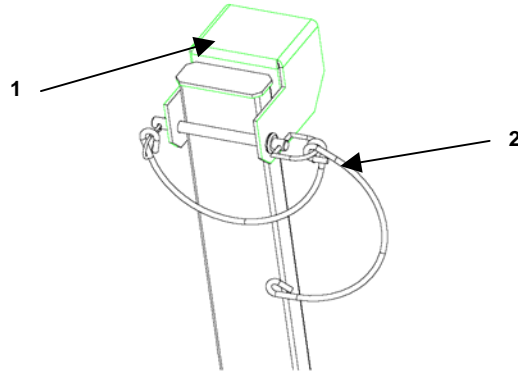

END OF WORK PACKAGE

UNIT MAINTENANCE**AUTHORIZED STOCKAGE LIST MOBILITY SYSTEM (ASLMS)**

**MODEL NUMBER FPU-8/12 PARTS (OD) P/N 15005002-001
NSN 5411-01-523-2071**

**MODEL NUMBER FPU-8/12 PARTS (DS) P/N 15005002-002
NSN 5411-01-523-2072**

**MODEL NUMBER FPU-8/12 BULK (OD) P/N 15005001-001
NSN 5411-01-523-2073**

**MODEL NUMBER FPU-8/12 BULK (DS) P/N 15005001-002
NSN 5411-01-523-2074**

DRAWER ASSEMBLY (FPU-12)**INSPECT, SERVICE, REPLACE****INITIAL SETUP:****Material/Parts**

Rags (Item 8, WP 0105 00)
Water

Tools

Drill (Item 2, WP 0063 00)
Drill Bit, 3/16" (Item 3, WP 0063 00)
General Mechanic's Tool Kit (Item 4, WP 0063 00)
Ladder (Item 6, WP 0063 00)

References

WP 0006 00

Personnel Required

One

Equipment Condition

ASLMS set-up.

INSPECT

1. Inspect drawer (1) for cracks, excessive dents or sagging. Notify direct support if any repairs are necessary. Replace drawer if necessary.
2. Open and close drawer assemblies (1) following steps outlined in WP 0006 00 to ensure proper operation (opens/closes without any binding, drawer stops work properly). Notify direct support if any repairs are necessary.

SERVICE

1. Remove debris and trash from drawer (1) as necessary.
2. Wipe drawer (1) interior and exterior with a wet rag as required.

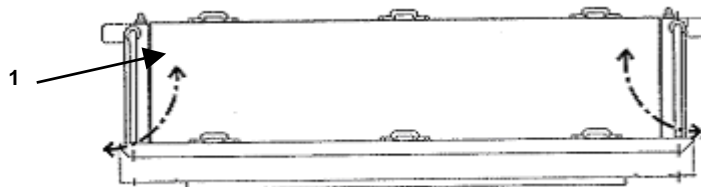

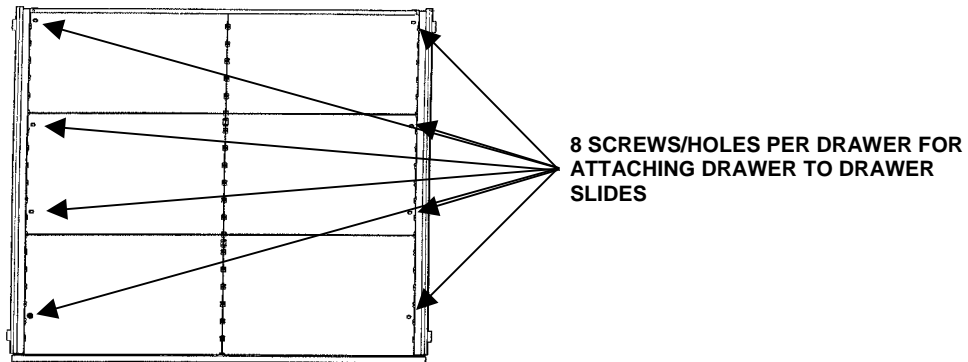
REPLACE

Replace drawer assembly if required. Drawer must be replaced if the locking tabs (1) or handles (2) fail to hold the drawer in the open or closed position and if there is excessive sagging or bending.

To replace:

1. Fully extend drawer to the open position. (If drawer will not stay in the open position this task will require two people. One to hold the drawer in the extended position and the other to perform drawer removal task).
2. Remove all stored material from drawer.
3. Remove eight 1/4-inch screws located in the bottom of the drawer at either side.
4. Lift drawer from slide ledge.
5. Position new drawer on the slide ledge being careful to align mounting holes.
6. Install eight 1/4-inch screws and slightly hand-tighten.
7. After hand tightening, push drawer completely closed and pull back to the full open position to allow drawer to seat into its proper location on the drawer slide ledge.
8. Being careful not to over tighten, secure the eight 1/4-inch mounting screws.

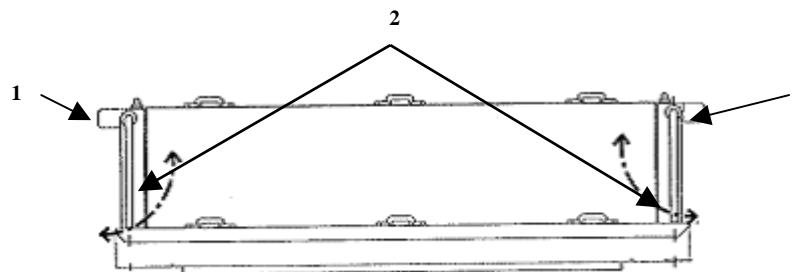

END OF WORK PACKAGE

UNIT MAINTENANCE**AUTHORIZED STOCKAGE LIST MOBILITY SYSTEM (ASLMS)**

**MODEL NUMBER FPU-8/12 PARTS (OD) P/N 15005002-001
NSN 5411-01-523-2071**

**MODEL NUMBER FPU-8/12 PARTS (DS) P/N 15005002-002
NSN 5411-01-523-2072**

**MODEL NUMBER FPU-8/12 BULK (OD) P/N 15005001-001
NSN 5411-01-523-2073**

**MODEL NUMBER FPU-8/12 BULK (DS) P/N 15005001-002
NSN 5411-01-523-2074**

SLIDE (FPU-12)**INSPECT, SERVICE, REPLACE****INITIAL SETUP:****Material/Parts**

Rags (Item 8, WP 0105 00)

Water

Tools

Drill (Item 2, WP 0063 00)

Drill Bit, 3/16" (Item 3, WP 0063 00)

General Mechanic's Tool Kit (Item 4, WP 0063 00)

Ladder (Item 6, WP 0063 00)

References

WP 0006 00

Personnel Required

Two

Equipment Condition

ASLMS set-up.

INSPECT

1. Inspect drawer FPU-12P slides (1) for operation, missing hardware per WP 0006 00.
2. Inspect drawer FPU-12P slides (1) for dirt/debris that would affect performance.

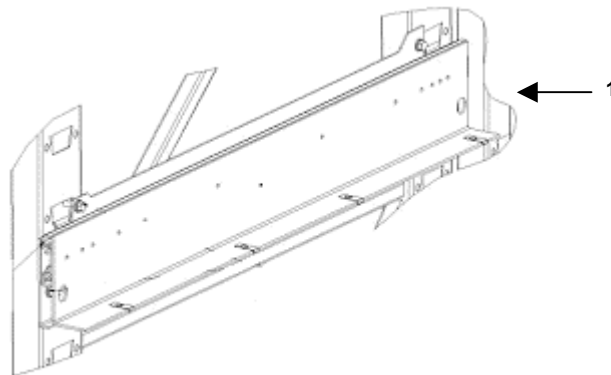
**SERVICE**

Wipe surfaces as necessary to keep equipment clean.

REPLACE

1. Fully extend drawer (1) to the open position. (If drawer will not stay in the open position this task will require two people. One person will hold the drawer in the extended position and the other person will remove the drawer.)
2. Remove all stored material from drawer.
3. Remove eight 1/4-inch screws located in the bottom of the drawer at either side (2).

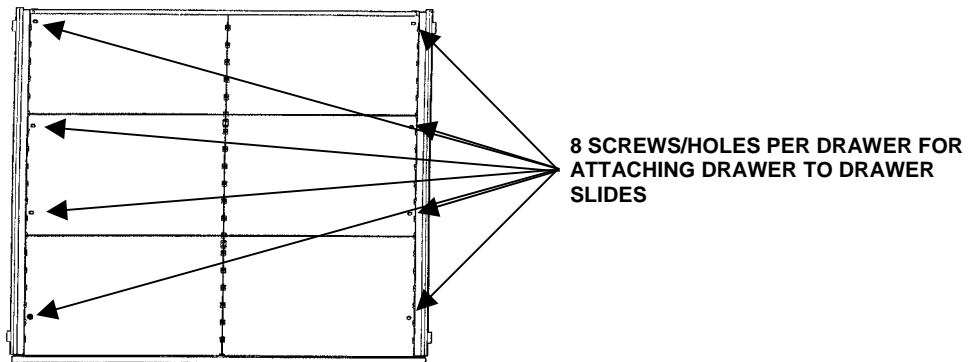
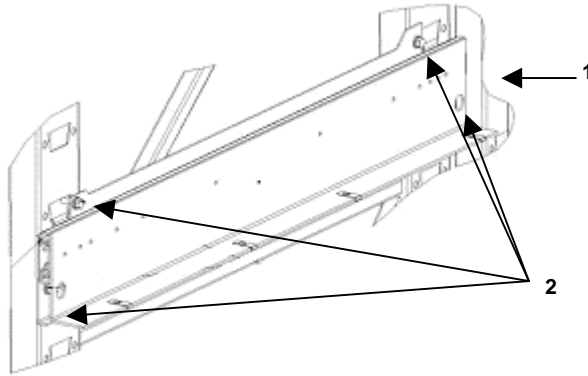

4. Lift drawer from slide ledge.
5. Remove the 5/16-inch diameter Allen head bolts using 3/16-inch Allen socket and 3/8-inch ratchet with extension from the slide ledge and vertical rack frame at each point.
6. Slide ledges are retained on the vertical rack frame by four bayonet tabs protruding into the windows of the vertical rack frame. This requires the ledge to be loosened from the vertical rack frame. While one person securely holds the slide ledge, the second person applies an upward force by tapping the underside of the slide ledge at the attached points with a 2 x 4 soft wooden block or similar material.
7. Place new slide ledge in the proper position by inserting the tabs into the vertical rack frame windows and tapping downward with a 2 x 4 soft wooden block or similar material. Be careful to align bolt-holes with grip nuts in the vertical rack frame.

8. Apply Loctite 262 red to the 5/16-inch diameter Allen head bolts.
9. Re-secure drawer slide ledge to rack frame with four 5/16-inch diameter Allen head bolts using a 3/16-inch hex head driver socket and 3/8-inch ratchet with extension.
10. Position new drawer on the slide ledge being careful to align mounting holes.

CAUTION

If a bolt is damaged beyond use, obtain a replacement. Do not install with less than the proper number of bolts or damage to equipment may occur.

11. Install eight 1/4-inch screws and slightly hand-tighten.
12. After hand tightening, push drawer completely closed and pull back to the full open position to allow drawer to seat into its proper location on the drawer slide ledge.
13. Being careful not to over tighten, secure the eight 1/4-inch mounting screws.
14. Reinstall drawer in accordance with WP 0006 00.

END OF WORK PACKAGE

UNIT MAINTENANCE

AUTHORIZED STOCKAGE LIST MOBILITY SYSTEM (ASLMS)

MODEL NUMBER FPU-8/12 PARTS (OD) P/N 15005002-001
NSN 5411-01-523-2071

MODEL NUMBER FPU-8/12 PARTS (DS) P/N 15005002-002
NSN 5411-01-523-2072

MODEL NUMBER FPU-8/12 BULK (OD) P/N 15005001-001
NSN 5411-01-523-2073

MODEL NUMBER FPU-8/12 BULK (DS) P/N 15005001-002
NSN 5411-01-523-2074

PALLET/CARGO NET FLOOR

INSPECT, SERVICE, REPAIR, REPLACE

INITIAL SETUP:

Material/Parts

Rags (Item 8, WP 0105 00)
Water

References

WP 0006 00

Tools

Drill (Item 2, WP 0063 00)
Drill Bit, 3/16" (Item 3, WP 0063 00)
General Mechanic's Tool Kit (Item 4, WP 0063 00)
Riveting Tool (Item 8, WP 0063 00)

Personnel Required

One

Equipment Condition

ASLMS set-up.

INSPECT

1. Inspect pallet (1) for cracks, excessive dents or sagging. Report to direct support maintenance for repair or replacement.
2. Inspect pallet for missing or damage D-rings (2). Report to direct support maintenance for repair.
3. Inspect the pallet for missing or damaged pallet locking pads (3). Report to direct support maintenance for repair.
4. Inspect cargo net, floor for damaged or missing items.

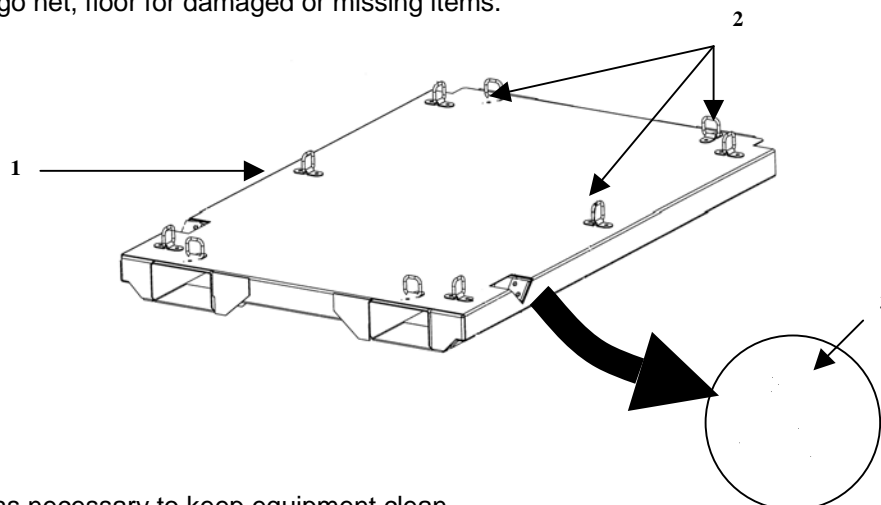

SERVICE

Wipe surfaces as necessary to keep equipment clean.

REPAIR

1. If pallet (1) becomes unserviceable replace the pallet following the procedures in WP 0006 00.
2. If pallet locking pads (2) are damaged or missing repair by removing rivets and securing new locking pads using number 3/16" drill bit and 3/16" rivets.
3. If cargo net floor (3) is missing or damaged beyond repair, replace with serviceable cargo net floor (3).
4. Repair cargo net floor (3) by replacing damaged or missing cargo net floor (3), 1-in. D-ring (4), snap safety hook (5), cord closure (6) with B-lock or 1/4-in. camouflage cord.

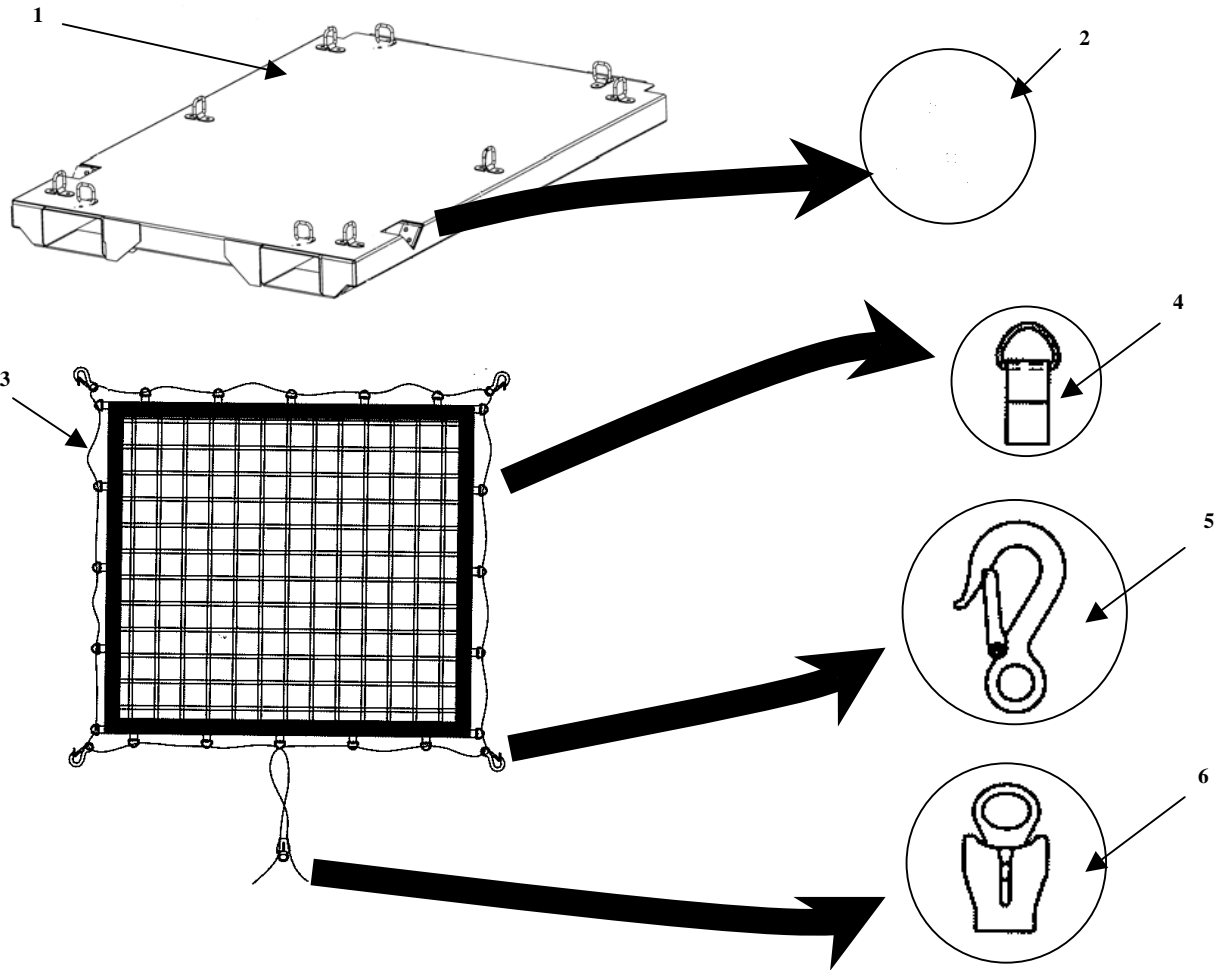

REPLACE

Refer to the pallet operation steps in WP 0006 00 for replacement of pallets.

END OF WORK PACKAGE

UNIT MAINTENANCE**AUTHORIZED STOCKAGE LIST MOBILITY SYSTEM (ASLMS)**

**MODEL NUMBER FPU-8/12 PARTS (OD) P/N 15005002-001
NSN 5411-01-523-2071**

**MODEL NUMBER FPU-8/12 PARTS (DS) P/N 15005002-002
NSN 5411-01-523-2072**

**MODEL NUMBER FPU-8/12 BULK (OD) P/N 15005001-001
NSN 5411-01-523-2073**

**MODEL NUMBER FPU-8/12 BULK (DS) P/N 15005001-002
NSN 5411-01-523-2074**

PALLET LEDGE**INSPECT, SERVICE, REPLACE, REPAIR****INITIAL SETUP:****Material/Parts**

Rags (Item 8, WP 0105 00)
Water

Tools

Drill (Item 2, WP 0063 00)
Drill Bit, 3/16" (Item 3, WP 0063 00)
General Mechanic's Tool Kit (Item 4, WP 0063 00)
Ladder (Item 6, WP 0063 00)

References

WP 0017 00

Personnel Required

One

Equipment Condition

ASLMS set-up.

INSPECT

1. Inspect pallet ledges (1) for cracks or excessive bends. Report to direct support for repair.
2. Inspect pallet ledges for proper operation of cam locks and missing hardware.
3. Inspect pallet ledges for dirt/debris that would affect performance.

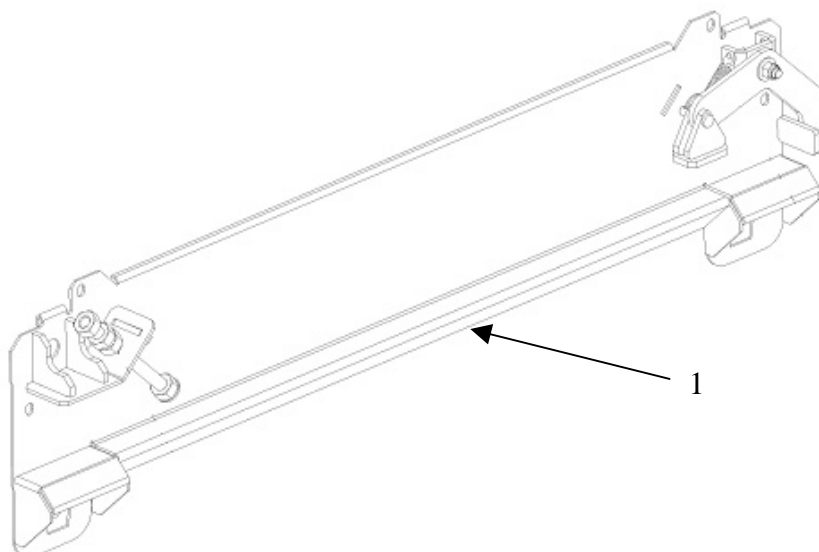

SERVICE

1. Wipe surfaces and cam lock mechanism as necessary.
2. Lubricate locking rod and cam locks as necessary (refer to WP 0017 00).

REPLACE

1. Remove pallet on ledge (1) to be replaced and any pallets located above or below to allow access.
2. Remove front and rear horizontal stabilizers (2) by removing the eight bolts using 3/16-inch hex head drive sockets and 3/8-inch ratchet with extension.
3. Remove eight Allen bolts (3) using 3/16-inch hex head drive socket and 3/8-inch ratchet with extension of the pallet ledge to be replaced.

CAUTION

If a bolt is damaged beyond use, obtain a replacement. Do not install with less than the proper number of bolts or damage to equipment may

4. Pallet ledges (1) are retained on the vertical rack frame by four bayonet tabs (4) protruding into the windows of the vertical rack frame. This requires the ledge to be loosened from the vertical rack frame. While one person securely holds the slide ledge, the second person applies an upward force by tapping the underside of the pallet ledge (1) at the attached points with a 2 x 4 soft wooden block or similar material.
5. Place new slide ledge in the proper position by inserting the tabs (4) into the vertical rack frame windows and tapping downward with a 2 x 4 soft wooden block or similar material. Be careful to align bolt holes with grip nuts in the vertical rack frame.

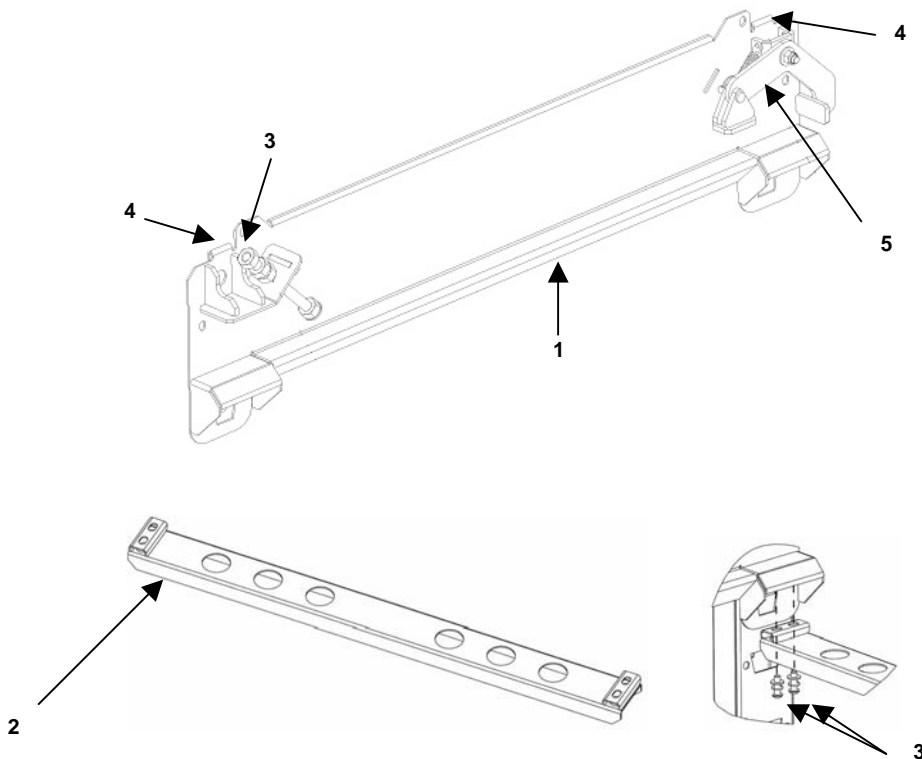

6. Apply Loctite 262 red to the 5/16-inch diameter Allen head bolts.
7. Insert ten 5/16-inch diameter Allen head bolts and finger tighten.
8. Tighten all 5/16-inch Allen head bolts using a 3/16-inch hex head driver socket and 3/8-inch ratchet with extension.
9. Reinstall rear pallet ledge horizontal stabilizer with the four Allen bolts using 3/16-inch hex head driver socket and 3/8-inch ratchet with extension.
10. Reinstall front pallet ledge horizontal stabilizer with the four Allen bolts using 3/16-inch hex head driver socket and 3/8-inch ratchet with extension.
11. Reinstall pallet ensuring the pallet cam lock is properly seated.

REPAIR

1. To repair the pallet ledge cam lock (1) the pallet ledge will have to be removed. To remove the pallet ledge (2) to be repaired, follow steps 1 through 9 above.
2. Remove the 1/2-inch x 5/8-inch cam shoulder bolt and 1/2-inch lock nut using a 1/4-inch Allen wrench and 9/16-inch socket and ratchet.
3. Detach spring from pallet ledge.
4. Attach spring of the new cam lock assembly to the pallet ledge.
5. Attach new cam lock assembly to pallet ledge using the 1/4-inch Allen wrench and 9/16-inch socket and ratchet.
6. Attach cam lock to pallet ledge using 1/4-inch Allen wrench and 9/16-inch socket and ratchet.
7. Reattach pallet ledge following steps 4 through 8 above.

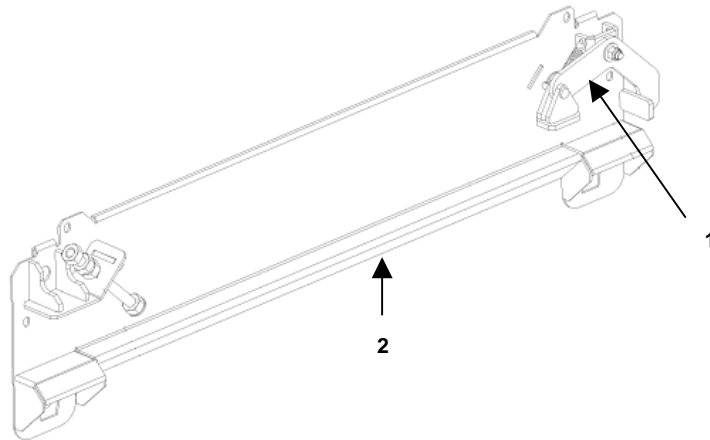

END OF WORK PACKAGE

UNIT MAINTENANCE**AUTHORIZED STOCKAGE LIST MOBILITY SYSTEM (ASLMS)**

**MODEL NUMBER FPU-8/12 PARTS (OD) P/N 15005002-001
NSN 5411-01-523-2071**

**MODEL NUMBER FPU-8/12 PARTS (DS) P/N 15005002-002
NSN 5411-01-523-2072**

**MODEL NUMBER FPU-8/12 BULK (OD) P/N 15005001-001
NSN 5411-01-523-2073**

**MODEL NUMBER FPU-8/12 BULK (DS) P/N 15005001-002
NSN 5411-01-523-2074**

FLOOR ADAPTER PLATE (FPU-8)**INSPECT, SERVICE, REPLACE, REPAIR****INITIAL SETUP:****Material/Parts**

Locktite 262 Red (Item 5, WP 0105 00)

Rags (Item 8, WP 0105 00)

Water

Tools

Drill (Item 2, WP 0063 00)

Drill Bit, 3/16" (Item 3, WP 0063 00)

General Mechanic's Tool Kit (Item 4, WP 0063 00)

Ladder (Item 6, WP 0063 00)

References

WP 0007 00, TM 9-237

Personnel Required

Two

Equipment Condition

ASLMS set-up.

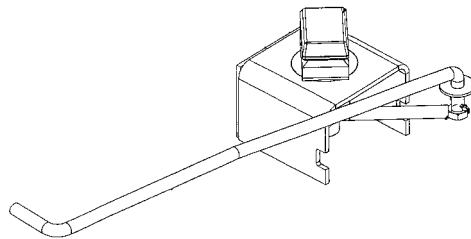
INSPECT

1. Inspect for dirt and debris that could affect performance.
2. Inspect for cracks at the point where the twist lock and module receptacles are welded to the adapter plate.
3. Pull and push the lock handle to ensure locking devices operate correctly per WP 0007 00.
4. Pull and push to check lock device motion.
5. Pull and push to check lock device motion.

SERVICE

Wipe surfaces as necessary to keep equipment clean.

REPLACE

1. Remove both modules per WP 0007 00.
2. Remove bolts (1) using 3/4-inch socket wrench.
3. Remove the floor adapter plate (2) from the FPU-8 using MHE with sling or strap.
4. Position replacement floor adapter plate using MHE and sling or strap inside FPU-8.
5. Apply locktite 262 red to the bolt threads.
6. Insert twelve bolts finger tight only.
7. Tighten using 3/4-inch socket.
8. Replace both modules per WP 0007 00.

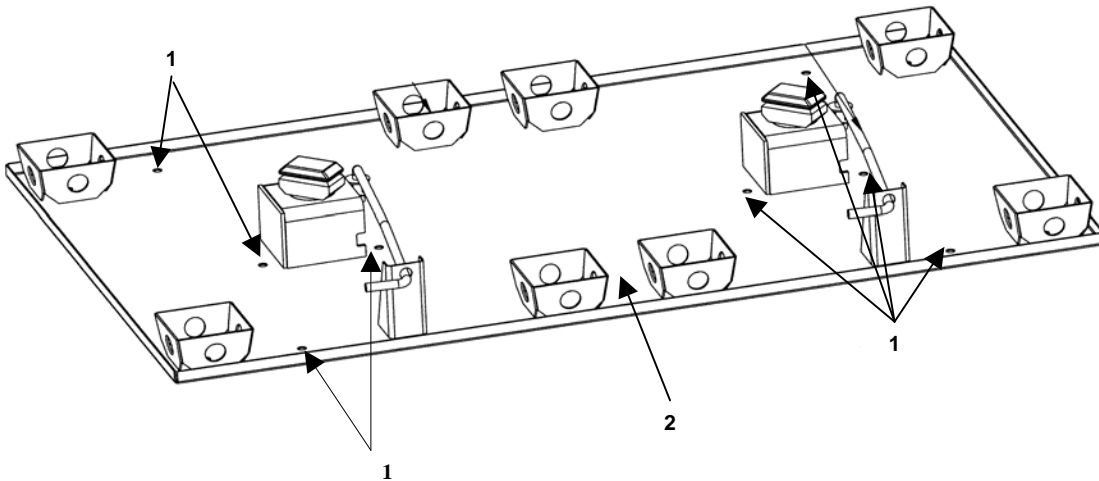
**REPAIR**

1. Floor adapter plate (1) may have to be removed from the FPU-8 in order to facilitate certain repairs.
2. Correct operator reported problems with floor adapter plate as required.
3. Cracks may occur in corners and around mounting holes and bracket welds.

WARNING

When welding near CARC paint, be advised that vapors may be hazardous to health if inhaled. Wear proper protective clothing, mask and gear when performing this task.

4. Repairs requiring welding will be made in accordance with standard Army welding principles in TM 9-237, Chapter 6.
5. Replace locking handle if found to be unserviceable.
6. Check for damaged or missing nylon pocket pads (2).

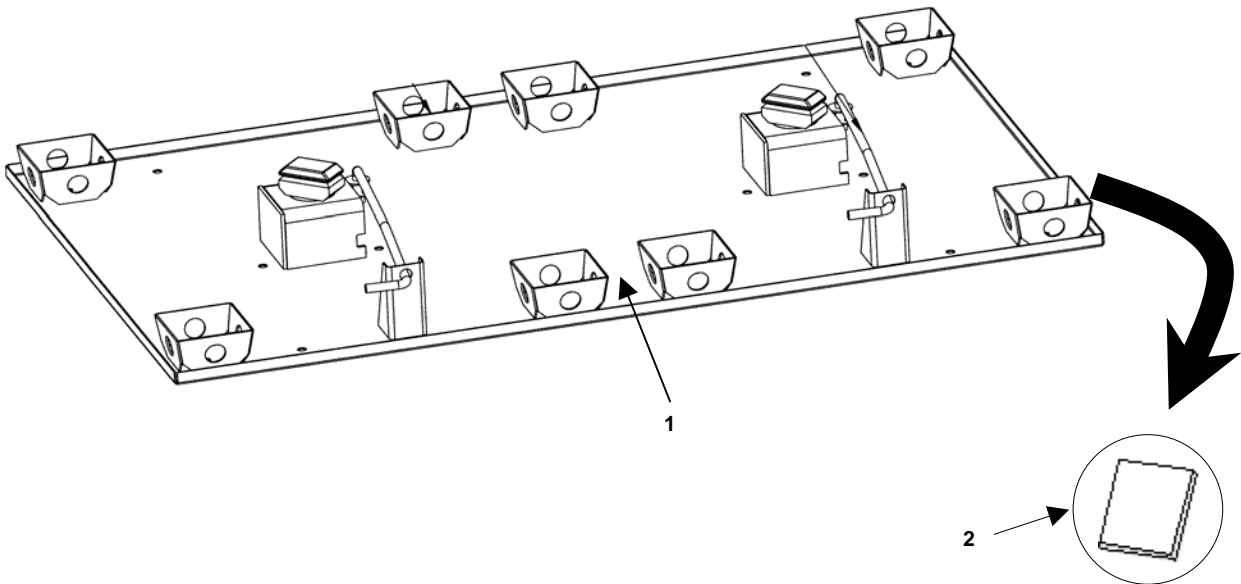

END OF WORK PACKAGE

UNIT MAINTENANCE

AUTHORIZED STOCKAGE LIST MOBILITY SYSTEM (ASLMS)

MODEL NUMBER FPU-8/12 PARTS (OD) P/N 15005002-001
NSN 5411-01-523-2071

MODEL NUMBER FPU-8/12 PARTS (DS) P/N 15005002-002
NSN 5411-01-523-2072

MODEL NUMBER FPU-8/12 BULK (OD) P/N 15005001-001
NSN 5411-01-523-2073

MODEL NUMBER FPU-8/12 BULK (DS) P/N 15005001-002
NSN 5411-01-523-2074

ASLMS MODULE (FPU-8)

INSPECT, SERVICE, REPLACE, REPAIR

INITIAL SETUP:

Material/Parts

Oil, Lubricating (Item 6, WP 0105 00)

References

WP 0007 00, TM 9-237

Tools

Drill (Item 2, WP 0063 00)

Drill Bit, 3/16" (Item 3, WP 0063 00)

General Mechanic's Tool Kit (Item 4, WP 0063 00)

Riveting Tool (Item 8, WP 0063 00)

Personnel Required

Two

Equipment Condition

ASLMS set-up.

INSPECT

1. Inspect the module for dirt/debris that would affect performance. Clean as required.
2. Inspect the module for the presence of the locking bar (1) and retaining clip.
3. Ensure all drawers are held closed by drawer latches (2).
4. Remove the locking bar.
5. Ensure the drawer latch on each drawer operates, allowing the drawer to open.
6. Ensure all drawers (3) can be fully extended and closed freely.
7. Ensure basket (4) (if attached) doors operate freely.

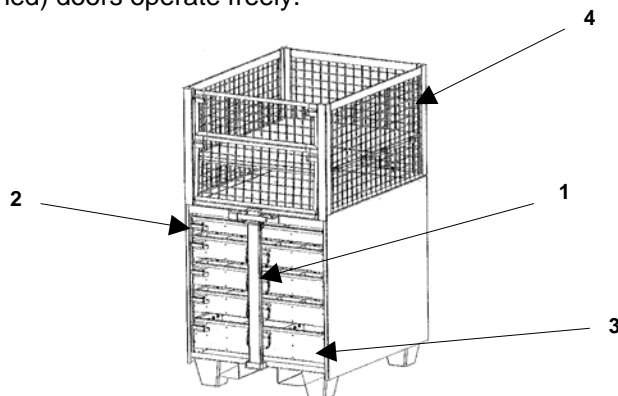

8. Ensure basket-locking tabs (if attached) are in the down and locked position.

9. Ensure the vinyl cover is in place, reattach if required.

SERVICE

1. To remove module for servicing, pull red handle ISO to the unlock position.
2. Remove module using MHE, lift module with drawers facing forklift.
3. Lubricate moving parts.
4. Position module over cradles.
5. Lower module into cradles.
6. Push the red handle ISO locking arm into the locked position.

REPLACE

1. Replace modules components (module cabinet, module basket, drawer assembly, module basket shelf assembly or 3G bar with pin and lanyard) if damaged beyond repair or if components are missing.
2. If removal of the module is necessary in order to facilitate repairs, remove module IAW WP 0007 00.

REPAIR

1. Correct operator level reported problems with module as required.
2. Remove module basket and drawers as required per WP 0007 00.
3. Repair the locking bar and retaining clip by drilling out rivet, replace with serviceable pin with lanyard using 3/16" rivet.
4. Remove damaged drawer latch, clean and smooth surface, weld replacement drawer latch.
5. Repair or replace any damaged or missing parts on the module basket or basket doors so that they operate freely.
6. Replace damaged or missing basket-locking tabs and loop ties as required on the module basket.
7. Repair or replace damaged or torn vinyl dust cover.

**WARNING**

When welding near CARC paint, be advised that vapors may be hazardous to health if inhaled. Wear proper protective clothing, mask and gear when performing this task.

8. Repairs requiring welding will be made in accordance with standard Army welding principles in TM 9-237, Chapter 6.

END OF WORK PACKAGE

UNIT MAINTENANCE

AUTHORIZED STOCKAGE LIST MOBILITY SYSTEM (ASLMS)

MODEL NUMBER FPU-8/12 PARTS (OD) P/N 15005002-001
NSN 5411-01-523-2071

MODEL NUMBER FPU-8/12 PARTS (DS) P/N 15005002-002
NSN 5411-01-523-2072

MODEL NUMBER FPU-8/12 BULK (OD) P/N 15005001-001
NSN 5411-01-523-2073

MODEL NUMBER FPU-8/12 BULK (DS) P/N 15005001-002
NSN 5411-01-523-2074

REAR ROLLER ASSEMBLY

INSPECT, SERVICE, REPLACE, REPAIR

INITIAL SETUP:**Material/Parts**

Oil, Lubricating (Item 6, WP 0105 00)
Rags (Item 8, WP 0105 00)
Water

References

WP 0005 00

Personnel Required

One

Tools

General Mechanic's Tool Kit (Item 4, WP 0063 00)

Equipment Condition

ASLMS set-up. Rollers attached.

INSPECT

1. Inspect the rear roller assembly (1) for dirt/debris that would affect performance. Clean as required.
2. Inspect the rear roller assembly for the presence of connector pins (2) and lynch pin retaining clips with lanyard (3).

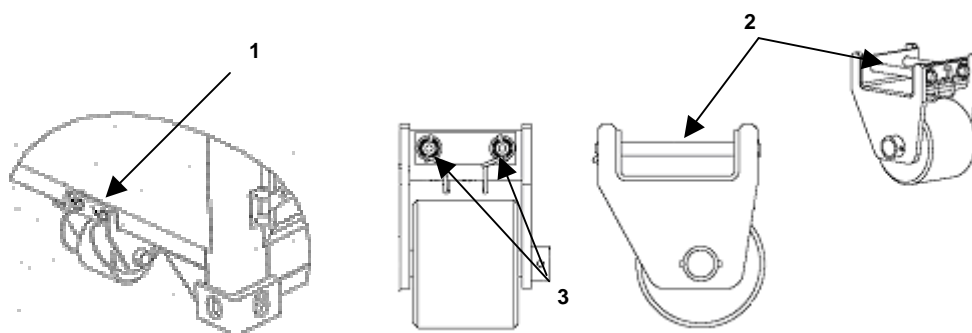
**SERVICE**

Remove debris from the roller assembly and clean with a wet rag.



WARNING

Always use properly rated forklift, crane or lifting device. Failure to comply could cause injury or equipment damage.

REPLACE

1. Raise container by lifting with the HEMTT-LHS or properly rated forklift. See WP 0005 00 for detailed procedures.
2. Remove the two 1/4-inch lynch pins with lanyard from the rear of the rear roller assembly attaching pins. Replace the two 1/4-inch lynch pins and lanyard if required.
3. While supporting the roller assembly, remove the 3/4-inch rear roller attaching pins.
4. Attach new rollers by aligning the holes in the rollers with the holes in the container and inserting 3/4-inch retention pins.
5. Reattach the 1/4-inch lynch pins with lanyard to the rear of 3/4-inch rear roller attaching pins

REPAIR

1. Remove the roller assembly (1) from the FPU-8.
2. Drive the roller pin (2) with a 5/16-inch flat punch, holding retaining collar to roller pin assembly.
3. Remove retaining collar (3).
4. Slide roller pin (2) from roller frame (1).
5. Replace worn/broken parts.
6. Replace broken or missing lynch pins and/or lanyard if required.
7. Apply lubricant.
8. Reinsert roller pin (2).
9. Reinsert the retaining collar (3) and secure with 5/16-inch rolled pin (2) with the hammer and flat punch.

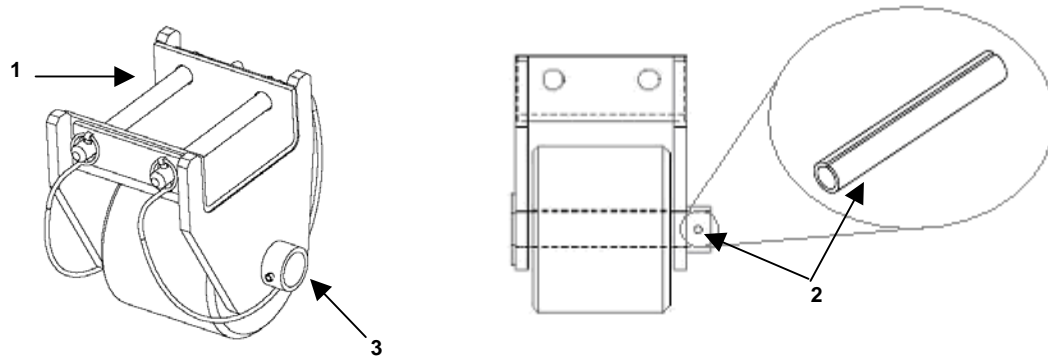

END OF WORK PACKAGE

UNIT MAINTENANCE**AUTHORIZED STOCKAGE LIST MOBILITY SYSTEM (ASLMS)**

**MODEL NUMBER FPU-8/12 PARTS (OD) P/N 15005002-001
NSN 5411-01-523-2071**

**MODEL NUMBER FPU-8/12 PARTS (DS) P/N 15005002-002
NSN 5411-01-523-2072**

**MODEL NUMBER FPU-8/12 BULK (OD) P/N 15005001-001
NSN 5411-01-523-2073**

**MODEL NUMBER FPU-8/12 BULK (DS) P/N 15005001-002
NSN 5411-01-523-2074**

CONNECTOR KIT**INSPECT, SERVICE, REPLACE****INITIAL SETUP:****Material/Parts**

Detergent (Item 1, WP 0105 00)
Grease, Molycote (Item 4, WP 0105 00)
Oil, Lubricating (Item 6, WP 0105 00)
Rags (Item 8, WP 0105 00)
Water

Tools

General Mechanic's Tool Kit (Item 4, WP 0063 00)
Ladder (Item 6, WP 0063 00)

References

WP 0005 00, WP 0017 00

Personnel Required

Two (plus one supervisor).

Equipment Condition

ASLMS set-up. Power disconnected.

INSPECT

1. Separate ASLMS containers per WP 0005 00.
2. Inspect bridge locks (1), load rail connector (2), and horizontal inter-connector (3) for lubrication and proper operation.

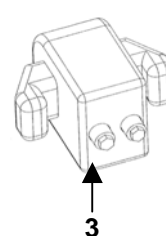
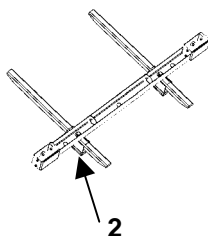
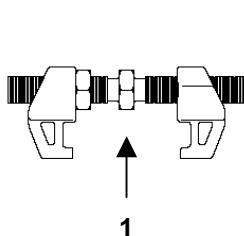
**SERVICE**

1. Clean using hot soapy water and lubricate the treads of the bridge locks (1) (refer to Table 2, WP 0017 00).
2. Clean using hot soapy water and lubricate bolt treads on horizontal inter-connectors (3) (refer to Table 2, WP 0017 00).
3. Clean using hot soapy water and lubricate transverse stabilizer tensioning blocks bolt treads (refer to Table 2, WP 0017 00).

- Clean using hot soapy water and lubricate loading rail connectors (refer to Table 2, WP 0017 00).

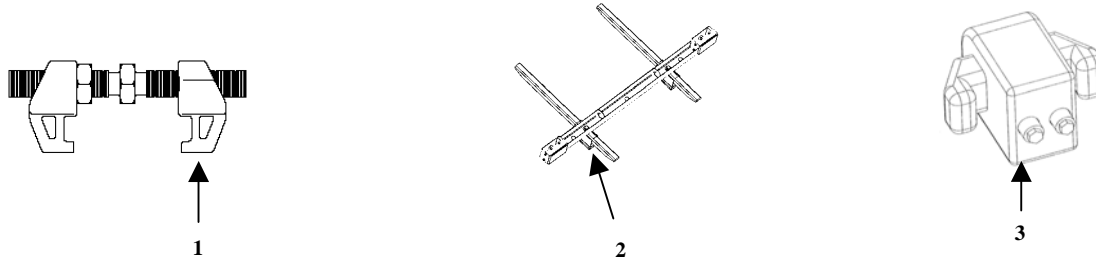

Bridge Locks

- Clean bridge lock threads using a degreaser.
- Lubricate the threads of the bridge locks (refer to Table 2 in WP 0017 00).

Horizontal Inter-connectors

- Disassemble using 9/16-inch and 3/4-inch wrenches.
- Thoroughly clean using a degreaser.
- The horizontal inter-connectors have operating threads and pivot points that must always be coated with waterproof grease to insure trouble-free operation. Completely fill the inside cavity of the inter-connector with Molykote (refer to table 2 in WP 0017 00).
- Rotate drive studs until threads are full out.
- Coat exposed threads with the same grease.
- Move studs in and out a few times to evenly distribute grease.
- In long-term exposure to corrosive environments, it is suggested the entire connection be covered externally to prevent the loss of interior lubricant.

Transverse Stabilizer

- Clean using a degreaser.
- Lubricate transverse stabilizer tensioning blocks bolt threads (refer to Table 2 in WP 0017 00).

Loading Rail Connector

- Clean using soapy water.
- Lubricate loading rail connectors (refer to Table 2 in WP 0017 00).

REPLACE

Connector components must be replaced if damaged. Remove and replace connector components as per WP 0005 00.

END OF WORK PACKAGE

UNIT MAINTENANCE**AUTHORIZED STOCKAGE LIST MOBILITY SYSTEM (ASLMS)**

**MODEL NUMBER FPU-8/12 PARTS (OD) P/N 15005002-001
NSN 5411-01-523-2071**
**MODEL NUMBER FPU-8/12 PARTS (DS) P/N 15005002-002
NSN 5411-01-523-2072**
**MODEL NUMBER FPU-8/12 BULK (OD) P/N 15005001-001
NSN 5411-01-523-2073**
**MODEL NUMBER FPU-8/12 BULK (DS) P/N 15005001-002
NSN 5411-01-523-2074**

FORK POCKET ADAPTER PLUG**INSPECT, SERVICE, REPLACE, REPAIR****INITIAL SETUP:****Material/Parts**

Detergent (Item 1, WP 0105 00)
Rags (Item 8, WP 0105 00)
Water

Tools

General Mechanic's Tool Kit (Item 4, WP 0062 00)

References

WP 0005 00

Personnel Required

Two (plus one supervisor).

Equipment Condition

ASLMS set-up. Power disconnected.
ASLMS securely positioned onto M1076
PLS trailer.

INSPECT

1. Ensure that fork pocket adapter plugs (1) (curb side and road side) are complete and serviceable.
2. Ensure hitch pins with lanyards (2) are attached and serviceable.

SERVICE

Clean using hot soapy water.

REPLACE

Components of the fork pocket adapter plugs must be replaced if damaged. Remove and replace components as per WP 0005 00.

REPAIR

1. Remove and replace damaged hitch lock pins with lanyards (3).
2. Replace damaged fork pocket adapter plugs in they become damaged or unserviceable beyond use.

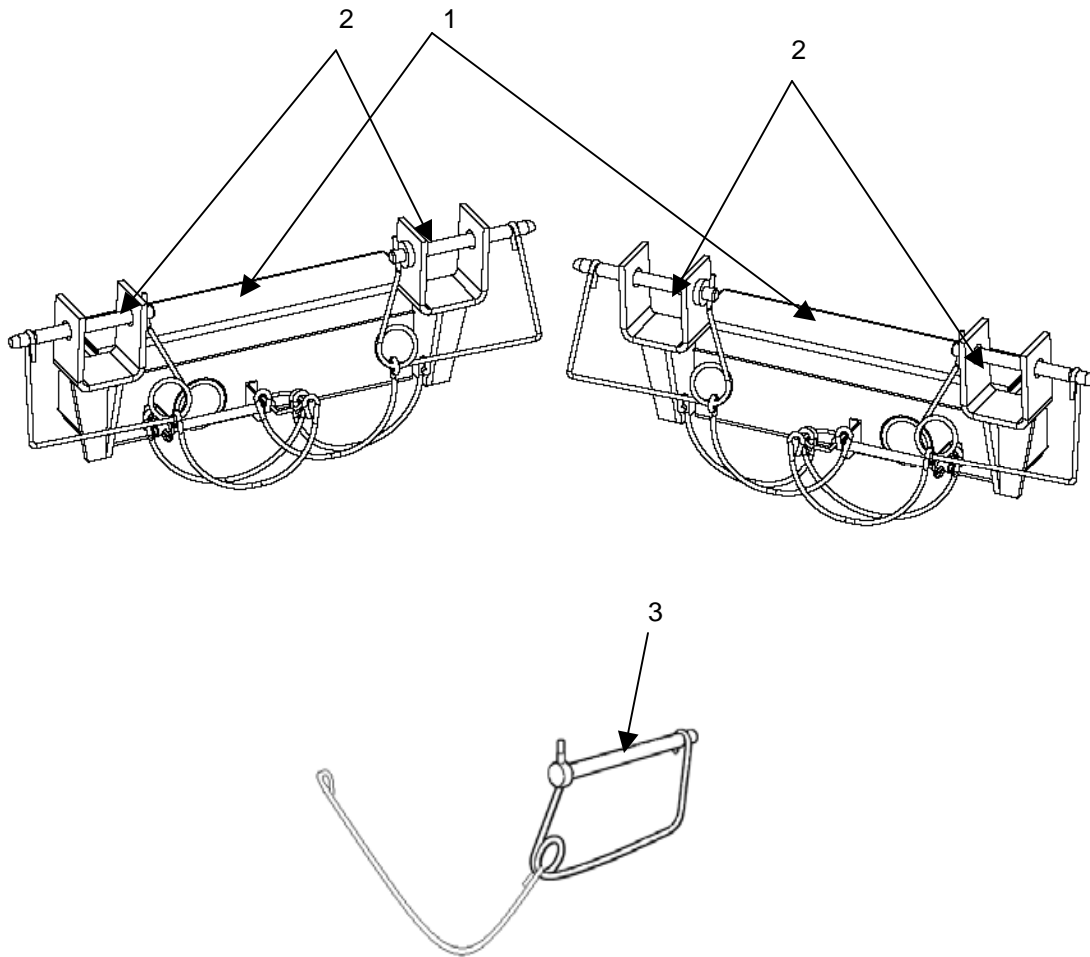

END OF WORK PACKAGE

UNIT MAINTENANCE**AUTHORIZED STOCKAGE LIST MOBILITY SYSTEM (ASLMS)**

**MODEL NUMBER FPU-8/12 PARTS (OD) P/N 15005002-001
NSN 5411-01-523-2071**

**MODEL NUMBER FPU-8/12 PARTS (DS) P/N 15005002-002
NSN 5411-01-523-2072**

**MODEL NUMBER FPU-8/12 BULK (OD) P/N 15005001-001
NSN 5411-01-523-2073**

**MODEL NUMBER FPU-8/12 BULK (DS) P/N 15005001-002
NSN 5411-01-523-2074**

DISTRIBUTION BOX**INSPECT****INITIAL SETUP:****Material/Parts****References****Tools**

Drill (Item 2, WP 0063 00)
Drill Bit, 3/16" (Item 3, WP 0063 00)
Ladder (Item 6, WP 0063 00)

Personnel Required

One

Equipment Condition

ASLMS set-up. Power Disconnected from M40 PDISE. Main breaker set to OFF position.

INSPECT**WARNING**

Electrical power must be disconnected before any electrical system work is performed to prevent electrical shock, injury, or death (electrocution). Only trained and qualified personnel (MOS 51R, 52C, 52E, or 52G) may perform maintenance or attempt to correct electrical discrepancies on the electrical system.

1. Ensure all power has been disconnected from the container before removing distribution box covers.
2. Inspect for missing cover plates (1), damaged boxes, missing hardware, or loose connections.
3. Report to direct support maintenance if any problems are discovered.

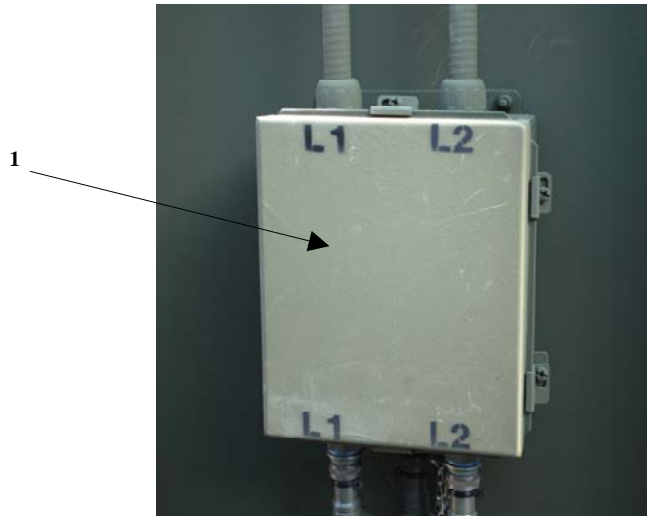

END OF WORK PACKAGE

UNIT MAINTENANCE

AUTHORIZED STOCKAGE LIST MOBILITY SYSTEM (ASLMS)

MODEL NUMBER FPU-8/12 PARTS (OD) P/N 15005002-001
NSN 5411-01-523-2071

MODEL NUMBER FPU-8/12 PARTS (DS) P/N 15005002-002
NSN 5411-01-523-2072

MODEL NUMBER FPU-8/12 BULK (OD) P/N 15005001-001
NSN 5411-01-523-2073

MODEL NUMBER FPU-8/12 BULK (DS) P/N 15005001-002
NSN 5411-01-523-2074

A/C

INSPECT

INITIAL SETUP:

Material/Parts

References

Personnel Required

One

Equipment Condition

ASLMS set-up. Disconnected from
PDISE. Main Breaker set to OFF position.

Tools

General Mechanic's Tool Kit (Item 4, WP 0063 00)

INSPECT

**WARNING**

Electrical power must be disconnected before any electrical system work is performed to prevent electrical shock, injury, or death (electrocution). Only trained and qualified personnel (MOS 51R, 52C, 52E, or 52G) may perform maintenance or attempt to correct electrical discrepancies on the electrical system.

1. Verify electrical (AC) connection (1) from the M40 PDISE (2) to the entrance panel of the FPU-12 (3).
2. Verify electrical (AC) connection of the FPU-8 (4) from the FPU-12 container.
3. Use a multi-meter to check the GFCI electrical outlets in the FPU-12 container.
4. Depress the GFCI test button to check ground fault circuit isolation.
5. Depress the reset button to reactivate the outlet power.
6. Repeat steps 4 and 5 for each GFCI electrical outlet.

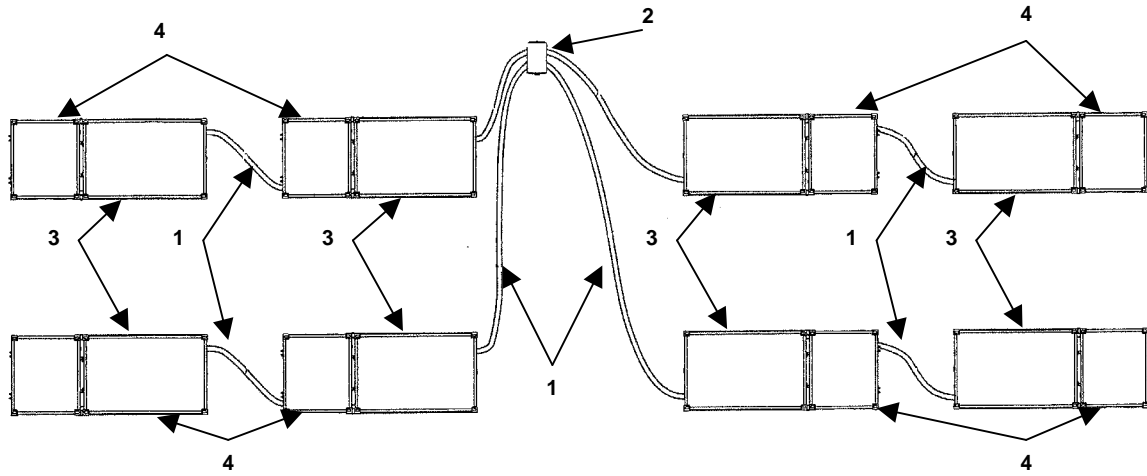

END OF WORK PACKAGE

UNIT MAINTENANCE

AUTHORIZED STOCKAGE LIST MOBILITY SYSTEM (ASLMS)

- MODEL NUMBER FPU-8/12 PARTS (OD) P/N 15005002-001
NSN 5411-01-523-2071
- MODEL NUMBER FPU-8/12 PARTS (DS) P/N 15005002-002
NSN 5411-01-523-2072
- MODEL NUMBER FPU-8/12 BULK (OD) P/N 15005001-001
NSN 5411-01-523-2073
- MODEL NUMBER FPU-8/12 BULK (DS) P/N 15005001-002
NSN 5411-01-523-2074

TRANSFORMER

INSPECT

INITIAL SETUP:

Material/Parts

References

Personnel Required

One

Equipment Condition

ASLMS set-up.

Tools

INSPECT

Inspect operation of lights and the exterior of transformer box (1) for discoloration that could be caused by excessive heat. Report to direct support maintenance if any problems are discovered.

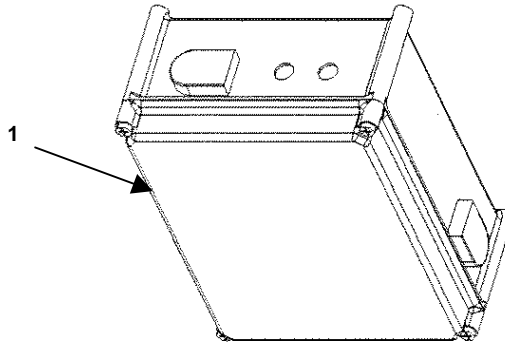

END OF WORK PACKAGE

UNIT MAINTENANCE

AUTHORIZED STOCKAGE LIST MOBILITY SYSTEM (ASLMS)

- MODEL NUMBER FPU-8/12 PARTS (OD) P/N 15005002-001
NSN 5411-01-523-2071
- MODEL NUMBER FPU-8/12 PARTS (DS) P/N 15005002-002
NSN 5411-01-523-2072
- MODEL NUMBER FPU-8/12 BULK (OD) P/N 15005001-001
NSN 5411-01-523-2073
- MODEL NUMBER FPU-8/12 BULK (DS) P/N 15005001-002
NSN 5411-01-523-2074

CABLE A/C

INSPECT, REPLACE

INITIAL SETUP:

Material/Parts

References

Personnel Required

One

Equipment Condition

ASLMS set-up. Power Disconnected from PDISE.

Tools

Main Breaker set to OFF position.

INSPECT



WARNING

Electrical power must be disconnected before any electrical system work is performed to prevent electrical shock, injury, or death (electrocution). Only trained and qualified personnel (MOS 51R, 52C, 52E, or 52G) may perform maintenance or attempt to correct electrical discrepancies on the electrical system.

Inspect cables (1 and 2) for frayed or cut insulation (3) cable end damage (4). Report to direct support maintenance if any problems are discovered.

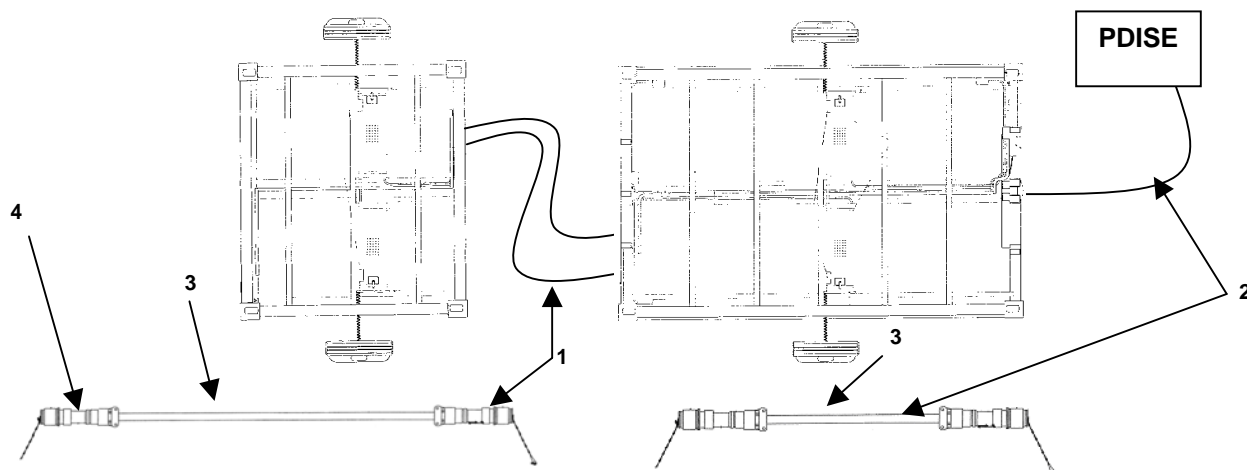

REPLACE

Replace any frayed cut or damaged AC 9-foot cables (1) between the containers or the 150-foot cables (2) from the M40 PDISE (3).

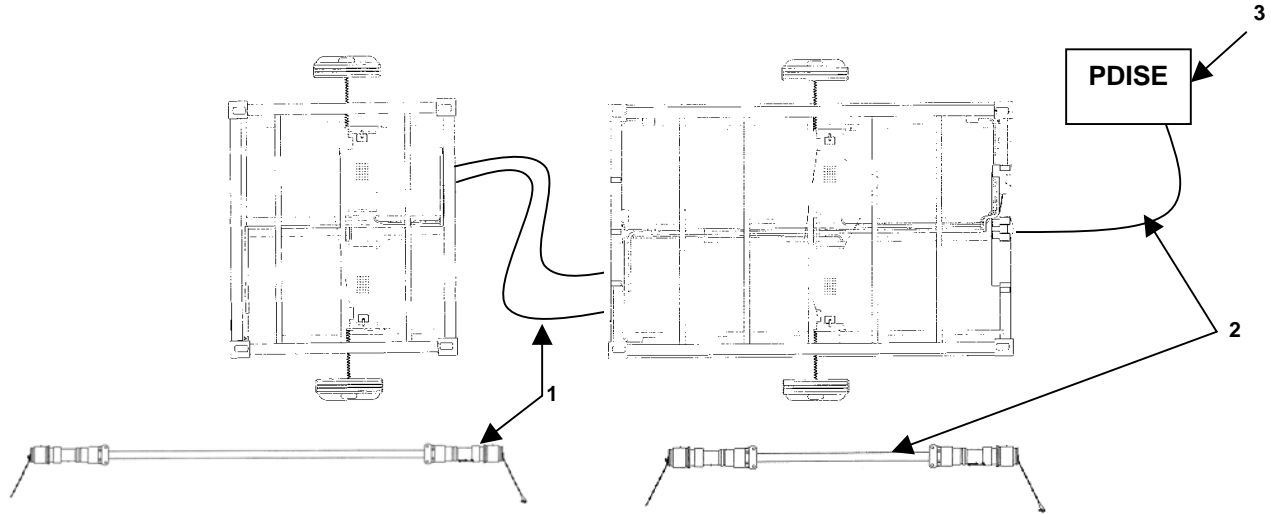

END OF WORK PACKAGE

UNIT MAINTENANCE**AUTHORIZED STOCKAGE LIST MOBILITY SYSTEM (ASLMS)**

**MODEL NUMBER FPU-8/12 PARTS (OD) P/N 15005002-001
NSN 5411-01-523-2071**

**MODEL NUMBER FPU-8/12 PARTS (DS) P/N 15005002-002
NSN 5411-01-523-2072**

**MODEL NUMBER FPU-8/12 BULK (OD) P/N 15005001-001
NSN 5411-01-523-2073**

**MODEL NUMBER FPU-8/12 BULK (DS) P/N 15005001-002
NSN 5411-01-523-2074**

RECEPTACLE GFCI**INSPECT, REPLACE, TEST****INITIAL SETUP:****Material/Parts****References****Personnel Required**

One

Equipment Condition

ASLMS set-up.

Tools**INSPECT**

With the container connected to a proper power source, inspect receptacles for operability using a standard power tool. If there is no power try to reset the reset button. If the reset button will not reset, replace receptacle.

REPLACE**WARNING**

Electrical power must be disconnected before any electrical system work is performed to prevent electrical shock, injury, or death (electrocution). Only trained and qualified personnel (MOS 51R, 52C, 52E, or 52G) may perform maintenance or attempt to correct electrical discrepancies on the electrical system.

1. Ensure all electrical power has been disconnected between the M40 PDISE and the FPU-12 external power connection point.
2. Remove the GFCI cover plate (1) and retaining screws.
3. Remove the GFCI retaining screws (2).
4. Pull the receptacle (3) from the box to reveal the black, white and ground wire connections (4).
5. Remove the black (hot), white (neutral), and ground wire connections (4).
6. To install the new GFCI receptacle (3) reconnect the black, white and ground wire connections (4).

7. Push the receptacle (3) into the box (5) and tighten the mounting screws (2).
8. Reinstall the mounting screws and cover plate (1).

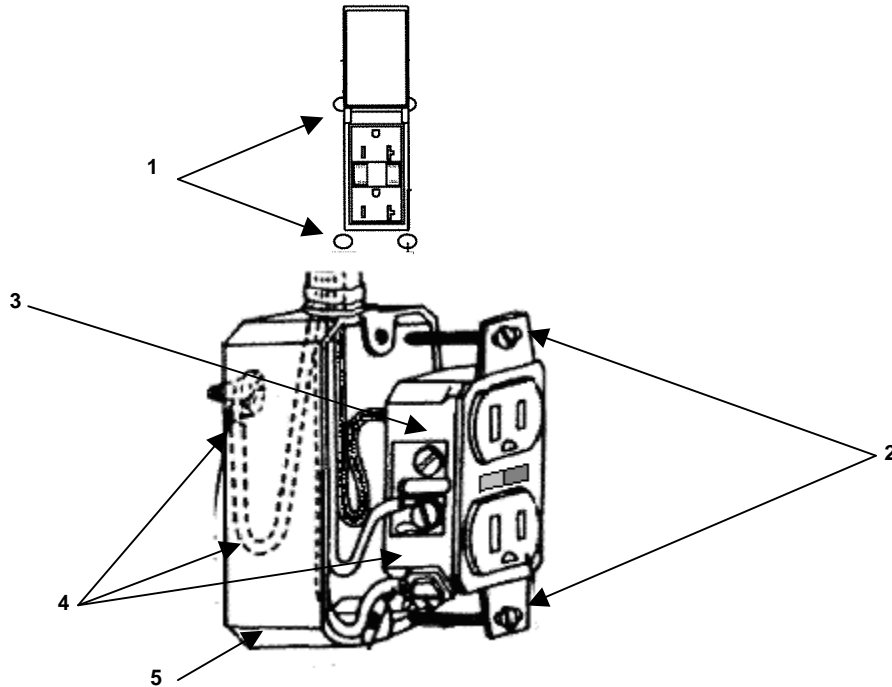

TEST

1. Newly installed GFCI receptacle (1) should be tested after installation and monthly.
2. Plug in an electrical device such as a common three-prong trouble light with light bulb.
3. Turn on the trouble light.
4. Press the test button (2). The light should go out and the reset button should pop out.
5. Press the reset button (3). The light should come on and the reset button should stay in.

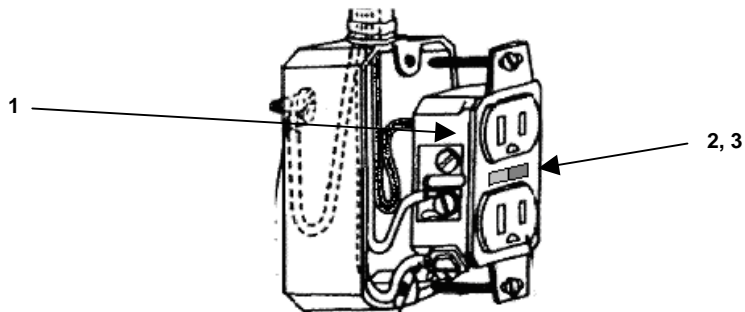

END OF WORK PACKAGE

UNIT MAINTENANCE

AUTHORIZED STOCKAGE LIST MOBILITY SYSTEM (ASLMS)

MODEL NUMBER FPU-8/12 PARTS (OD) P/N 15005002-001
 NSN 5411-01-523-2071

MODEL NUMBER FPU-8/12 PARTS (DS) P/N 15005002-002
 NSN 5411-01-523-2072

MODEL NUMBER FPU-8/12 BULK (OD) P/N 15005001-001
 NSN 5411-01-523-2073

MODEL NUMBER FPU-8/12 BULK (DS) P/N 15005001-002
 NSN 5411-01-523-2074

D/C

INSPECT

INITIAL SETUP:

Material/Parts

References

Personnel Required

One

Equipment Condition

ASLMS set-up.

Tools

INSPECT

CAUTION

Place the light on top of a pallet or module within the container for support while checking the lights, to prevent damage to the light fixture.

1. Verify the electrical (D/C) connection from the FPU-8 to the FPU-12 container.
2. Remove the lights (1) from the storage containers, insure the coiled wire fits into the cutout provided and close the box and turn them on white and red.
3. Insure there are no burned out florescent tubes (2), or a cracked cover lens (3).

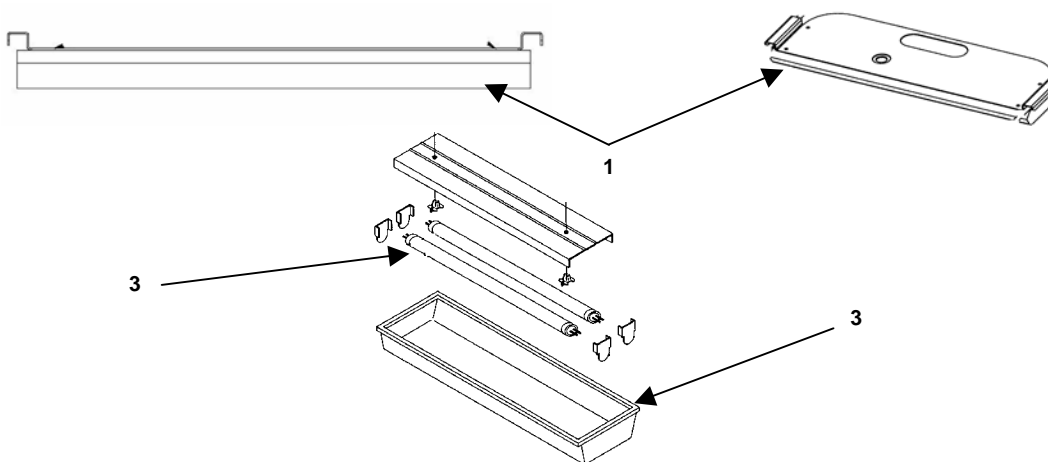

END OF WORK PACKAGE

UNIT MAINTENANCE

AUTHORIZED STOCKAGE LIST MOBILITY SYSTEM (ASLMS)

- MODEL NUMBER FPU-8/12 PARTS (OD) P/N 15005002-001
NSN 5411-01-523-2071
- MODEL NUMBER FPU-8/12 PARTS (DS) P/N 15005002-002
NSN 5411-01-523-2072
- MODEL NUMBER FPU-8/12 BULK (OD) P/N 15005001-001
NSN 5411-01-523-2073
- MODEL NUMBER FPU-8/12 BULK (DS) P/N 15005001-002
NSN 5411-01-523-2074

CABLE D/C

INSPECT, REPLACE

INITIAL SETUP:

Material/Parts

References

Personnel Required

One

Equipment Condition

ASLMS set-up. Power Disconnected from PDISE. Main Breaker set to OFF position.

Tools

INSPECT

Inspect cable for frayed or cut insulation and cable end damage. Report to direct support maintenance if any problems are discovered.

REPLACE

1. Disconnect container from power source.
2. Turning counter clockwise, disconnect D/C lines from the FPU-12 (1).
3. Turning counter clockwise, disconnect D/C lines from the FPU-8 (2).
4. Install new 9-foot DC power cord (3) (DC power cord plugs are two pin and will only fit into DC receptacles).

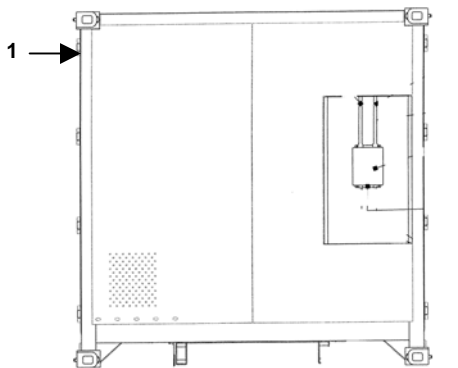

REAR FPU-12 9-FOOT DC CONNECTION

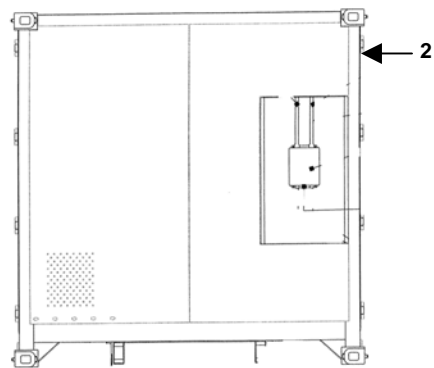

FRONT FPU-8 DC CONNECTION

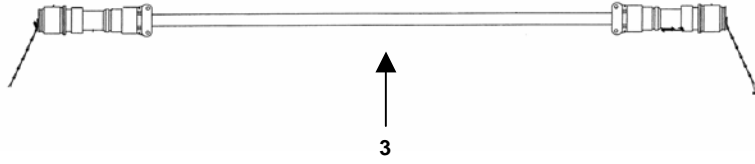

END OF WORK PACKAGE

AUTHORIZED STOCKAGE LIST MOBILITY SYSTEM (ASLMS)

**MODEL NUMBER FPU-8/12 PARTS (OD) P/N 15005002-001
NSN 5411-01-523-2071**

**MODEL NUMBER FPU-8/12 PARTS (DS) P/N 15005002-002
NSN 5411-01-523-2072**

**MODEL NUMBER FPU-8/12 BULK (OD) P/N 15005001-001
NSN 5411-01-523-2073**

**MODEL NUMBER FPU-8/12 BULK (DS) P/N 15005001-002
NSN 5411-01-523-2074**

12-VOLT LIGHT ASSEMBLY

INSPECT

**INITIAL SETUP:
Material/Parts**

References

**Personnel Required
One**

**Equipment Condition
ASLMS set-up.**

**Tools
Ladder (Item 6, WP 0063 00)**

INSPECT

1. Inspect coiled wire (1) on light fixture for frayed or cut insulation and exposed wires. Report to Direct Support for repair.
2. Inspect light fixture (2) for operability, broken covers or missing hardware. Report to Direct Support for repair.
3. Inspect D/C cable (3) for frayed or cut insulation.
4. Inspect the four light support poles (4) for completeness and serviceability. Replace or repair as necessary.

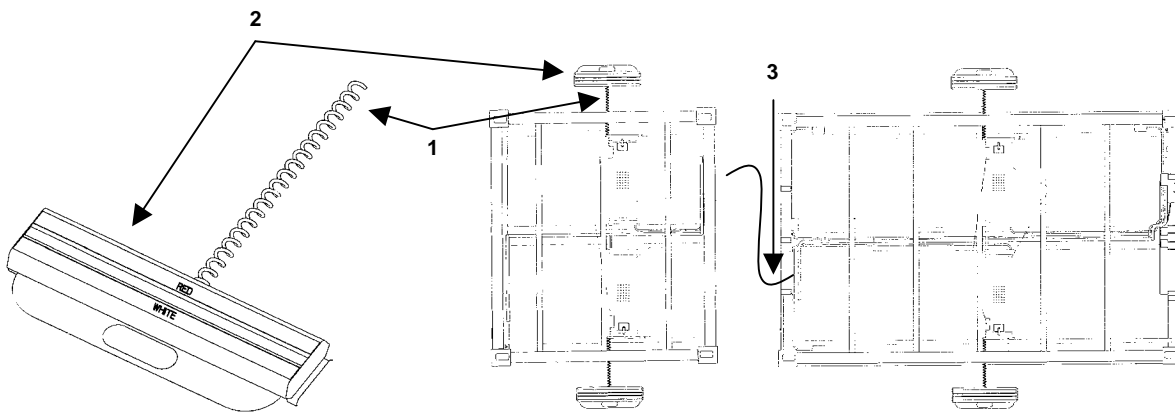

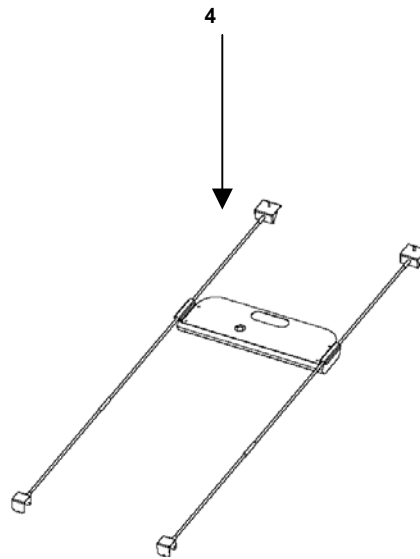

END OF WORK PACKAGE

AUTHORIZED STOCKAGE LIST MOBILITY SYSTEM (ASLMS)

**MODEL NUMBER FPU-8/12 PARTS (OD) P/N 15005002-001
NSN 5411-01-523-2071**

**MODEL NUMBER FPU-8/12 PARTS (DS) P/N 15005002-002
NSN 5411-01-523-2072**

**MODEL NUMBER FPU-8/12 BULK (OD) P/N 15005001-001
NSN 5411-01-523-2073**

**MODEL NUMBER FPU-8/12 BULK (DS) P/N 15005001-002
NSN 5411-01-523-2074**

VENT SYSTEM

INSPECT, REPLACE, REPAIR

INITIAL SETUP:

Material/Parts

Oil, Lubricating (Item 6, WP 0105 00)

References

Personnel Required

One

Equipment Condition

ASLMS set-up.

Tools

General Mechanic's Tool Kit (Item 4, WP 0063 00)

Ladder (Item 6, WP 0063 00)

INSPECT

1. Inspect vent cover release assembly (1) for proper operation and alignment. Align or replace as necessary.
2. Inspect vent device for obstruction and debris. Clean as necessary.
3. Inspect filter housing for proper fit. Replace as necessary.
4. Inspect vent cover release and reset cables for proper operation. Replace cables as necessary.
5. Inspect vent cables for lubrication. Lubricate as necessary.

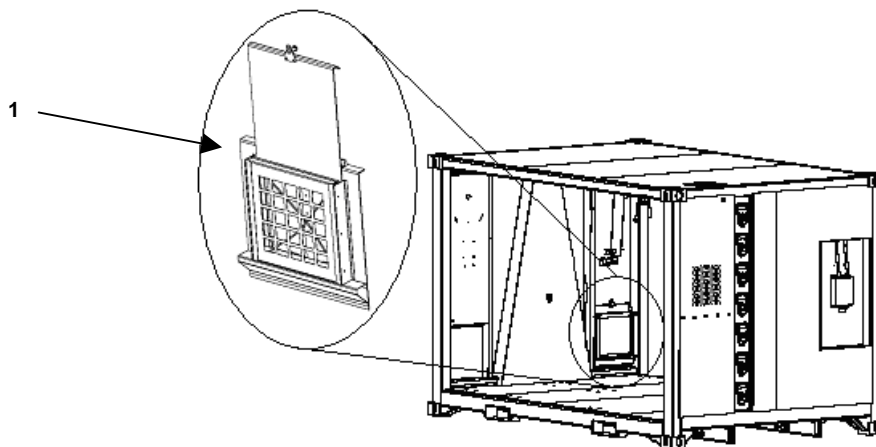

REPLACE**Replace broken vent cover release assembly as follows:**

1. Ensure vent cover (1) is in the closed position.
2. Disconnect the release cable from the vent cover release assembly (2) by removing the cable stop.
3. Remove two each 1/4-inch hex head bolts and nuts (3, 4) from the vent cover release assembly (5) using a 7/16-inch socket and ratchet.
4. Attach the new vent cover release cable to the vent cover release assembly by feeding cable through release lever and reattaching the cable stop.
5. Attach the new vent cover release assembly (5) to the container with two each 1/4-inch hex head bolts using a 7/16-inch socket and ratchet. Do not tighten these bolts.
6. To align, pull the reset handle until the vent cover is locked in the open position.
7. Tighten the two each 1/4-inch hex head bolts and nuts (3, 4) using a 7/16-inch socket and ratchet.

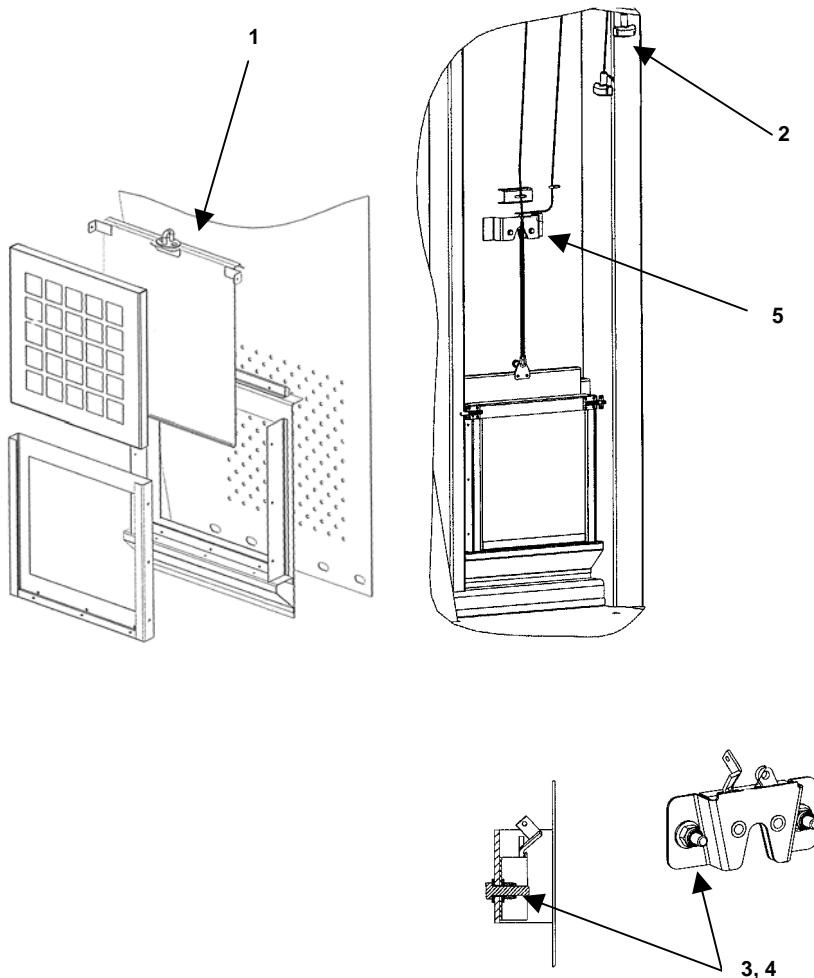

Replace filter housing as follows:

1. Close vent cover (1) using red banded release handle (2).
2. Slide the two barrel bolts (3) on the filter-retaining lid (4) and remove.
3. Remove filter housing (5) by sliding upward.
4. Insert new filter housing (5) with filter (6).
5. Reinstall the filter-retaining lid (4). Push the barrel bolts (3) outward to lock the retaining lid in place.
6. Using the black reset handle (2) pull until the vent cover is set in the open position.

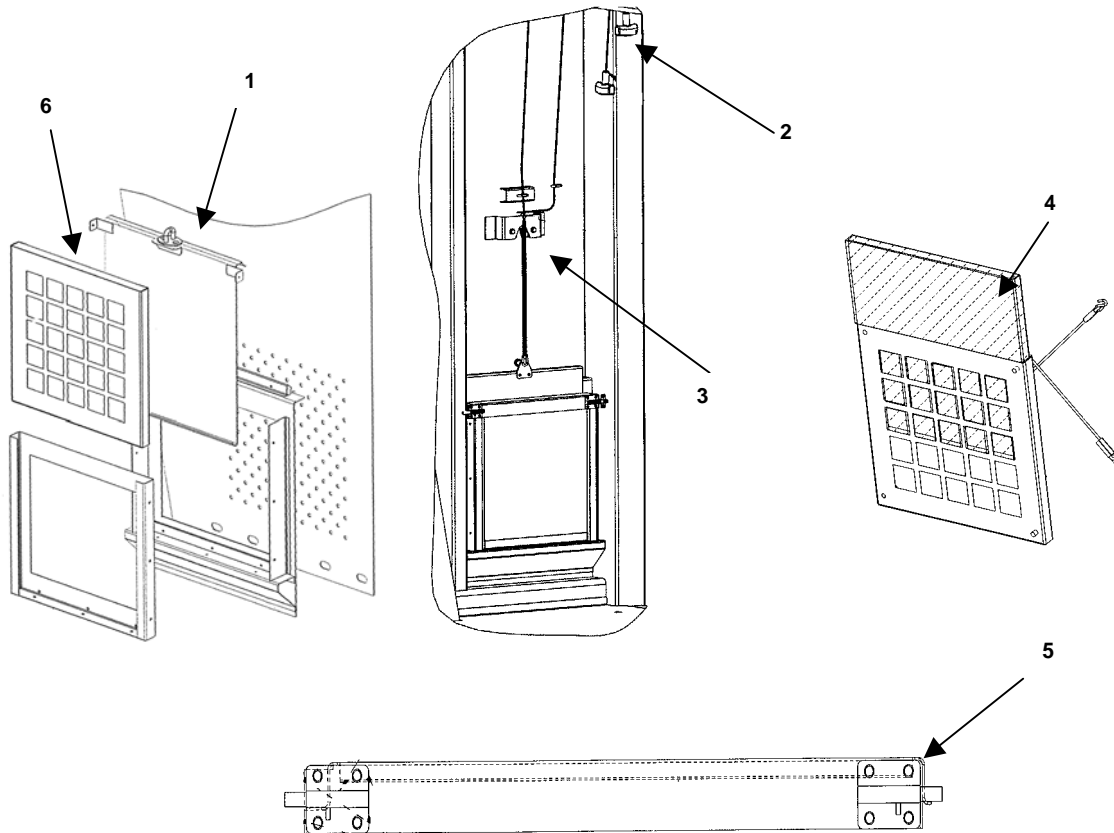

Replace vent cover release/reset cable as follows:

1. Close vent cover (1) using red banded release handle (2).
2. Disconnect the vent release cable from the vent cover release assembly by removing the cable stop.
3. Remove release cable from the red/black handle by removing the cable stop.
4. Cut a length of 304 stainless steel, nylon coated, 1/8-inch wire rope. Obtain proper length from the table below.

Release Cable Curb Side	84-inches
Release Cable Street Side	38-inches
Reset Cable Curb Side	74-inches
Reset Cable Street Side	60-inches

5. Remove two inches of nylon coating on both ends of the cable.
6. Route one end through the bottom to the top of the release/reset handle.
7. Attach a cable stop.
8. Route cable through appropriate cable guide. For reset cable, route through the cable guide and pulley.
9. Attach release cable by routing through the vent cover release lever and attaching a cable stop. Attach reset cable by routing through the vent cover chain length and crimp using a cable sleeve.
10. Using the black reset handle (3) pull until the vent cover is set in the open position.

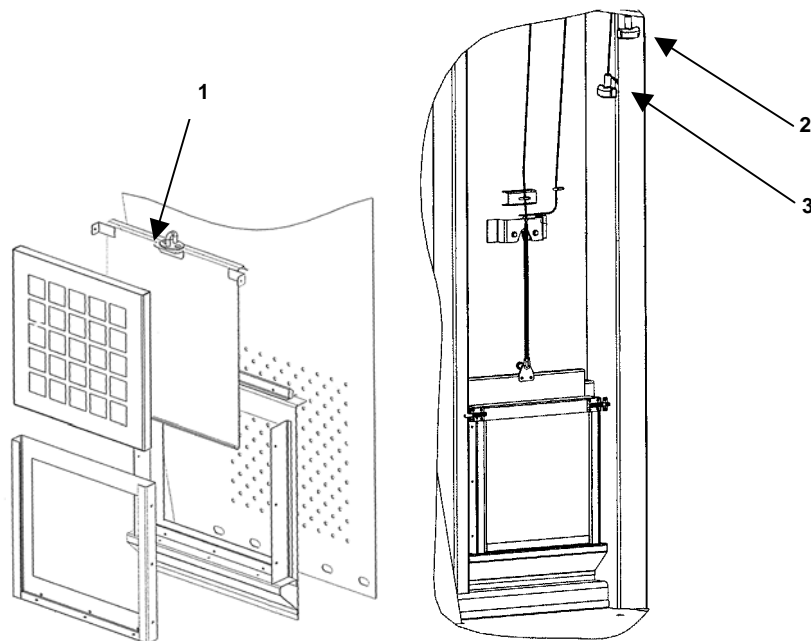

REPAIR

Repair ventilation device as required by ensuring filter cover plate is properly aligned and free of debris if it cannot be raised or lowered as reported by operator.

END OF WORK PACKAGE

UNIT MAINTENANCE**AUTHORIZED STOCKAGE LIST MOBILITY SYSTEM (ASLMS)**

**MODEL NUMBER FPU-8/12 PARTS (OD) P/N 15005002-001
NSN 5411-01-523-2071**

**MODEL NUMBER FPU-8/12 PARTS (DS) P/N 15005002-002
NSN 5411-01-523-2072**

**MODEL NUMBER FPU-8/12 BULK (OD) P/N 15005001-001
NSN 5411-01-523-2073**

**MODEL NUMBER FPU-8/12 BULK (DS) P/N 15005001-002
NSN 5411-01-523-2074**

VENT FILTER**INSPECT, REPLACE****INITIAL SETUP:****Material/Parts****References****Personnel Required**

One

Equipment Condition**Tools**

ASLMS set-up.

INSPECT

1. Close vent cover (1) using the black handle (2) with red band.
2. Slide the two barrel bolts (3) on filter-retaining lid (4) inward to their open position and remove retaining lid (4).
3. Remove the filter (5) and housing (6).
4. Unhook bungee cords (7) from the back of the filter housing (6).
5. Pull filter material from housing (6).

CAUTION

The filters have a yellow surface that will always be installed facing the interior of the container to properly filter the ASLMS.

6. Ensure filter-retaining bracket (8) is free of dirt and debris.
7. Inspect the yellow side of the filter for:
 - a. Significant discoloration of the visible yellow side from dirt and grit.
 - b. Tears and holes through entire filter material.
8. If the filter is unserviceable, the filter must be replaced (the filter cannot be cleaned and must be discarded).
9. If the filter is serviceable:

- a. Insert the serviceable filter media (5) back into the housing (6) with the yellow side facing to the inside of the container and the white side facing toward the outside. The yellow side of the media must be inserted facing the square holes in the filter housing (6).
- b. Slide the filter housing (6) back into the ventilation system (8). Filter bungee cords (7) should be facing back towards the outside of the container.
- c. Reinstall the filter-retaining lid (4). Push the barrel bolts (3) outward to lock the retaining lid in place.
- d. Pull the handle (9) to release the cover plate to the closed position.
- e. Using the black pull handle (2) reset the ventilation cover plate to the open position.

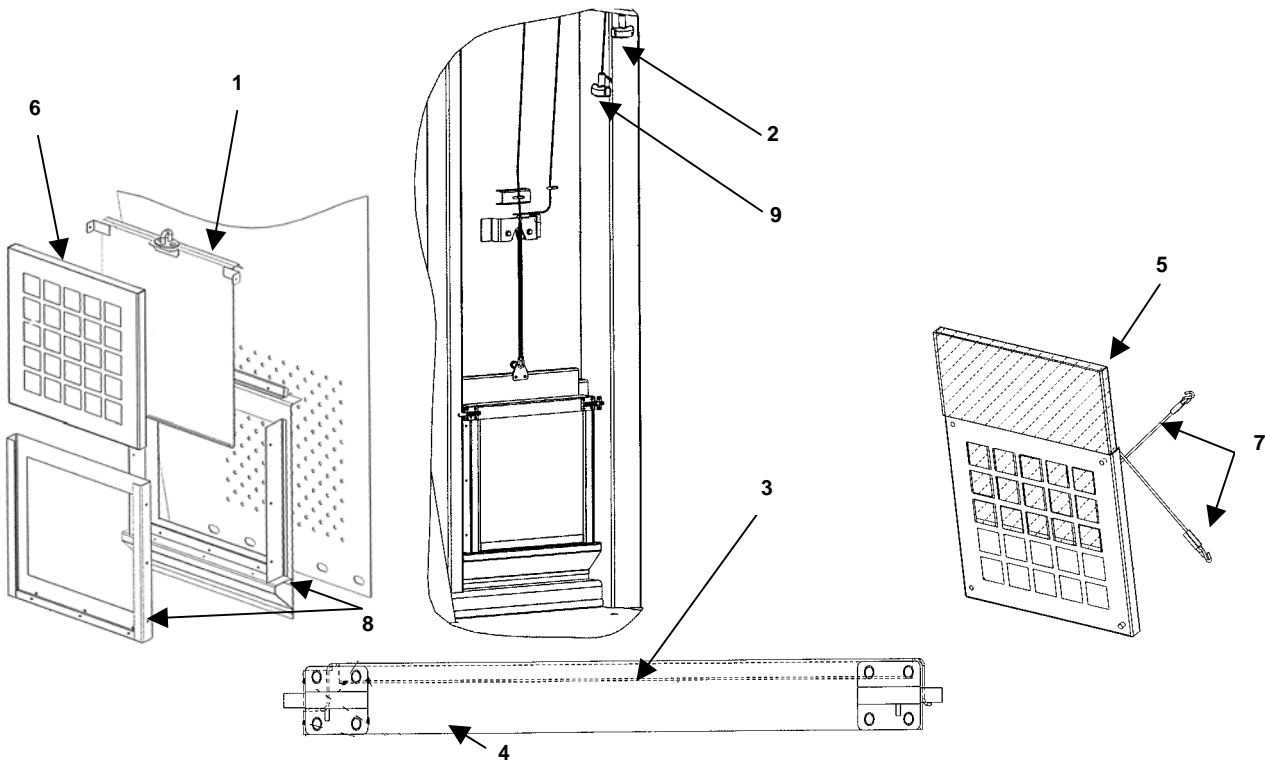

REPLACE

1. Using the black handle (1) with red band, pull to release ventilation cover plate from open position.
2. Slide the two barrel bolts on filter-retaining lid (2) inward to their open position and remove retaining lid (2).
3. Pull filter housing (3) upward until it is clear of the ventilation system (4).
4. Remove the two bungee cords (5) from the filter housing (3).
5. Remove old filter media from filter housing (3).

6. Clean filter housing (3) as necessary.
7. Insert new filter media (6) with the yellow side facing to the inside of the container and the white side facing towards the outside. The yellow side of media must be inserted facing the square holes of the filter housing (3).
8. Reinstall the two bungee cords (5) into the filter housing (3).
9. Slide the filter housing (3) back into the ventilation system (4). Filter bungee cords must be facing towards the outside of the container.
10. Reinstall the filter-retaining lid (2).
11. Pull the red handle (7) to release the cover plate to the closed position.
12. Pull the black pull handle (1) to place the vent cover (8) in the open position.

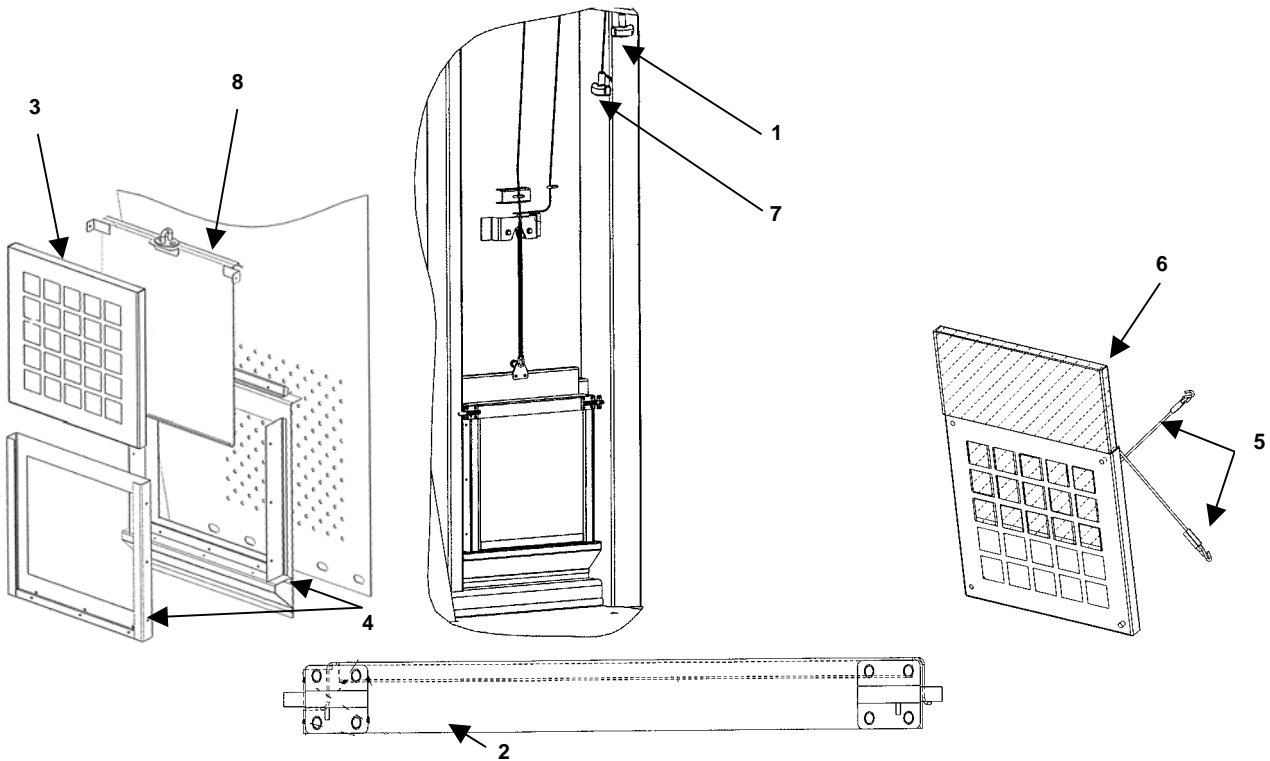

END OF WORK PACKAGE

UNIT MAINTENANCE**AUTHORIZED STOCKAGE LIST MOBILITY SYSTEM (ASLMS)**

**MODEL NUMBER FPU-8/12 PARTS (OD) P/N 15005002-001
NSN 5411-01-523-2071**

**MODEL NUMBER FPU-8/12 PARTS (DS) P/N 15005002-002
NSN 5411-01-523-2072**

**MODEL NUMBER FPU-8/12 BULK (OD) P/N 15005001-001
NSN 5411-01-523-2073**

**MODEL NUMBER FPU-8/12 BULK (DS) P/N 15005001-002
NSN 5411-01-523-2074**

ELEMENT PROTECTIVE COVER (EPC) SECURING KIT**INSPECT, SERVICE, REPAIR, REPLACE****INITIAL SETUP:****Material/Parts**

Rags (Item 8, WP 0105 00)
Water

References**Personnel Required**

One

Equipment Condition

EPC bag removed from its stowed location.

Tools

General Mechanic's Tool Kit (Item 4, WP 0063 00)

INSPECT

1. Inspect EPC storage bracket for dirt or debris.
2. Inspect the EPC frame pole storage bracket for broken or missing retention pins.
3. Inspect the EPC frame pole storage bracket for broken, frayed or missing lanyard connectors.

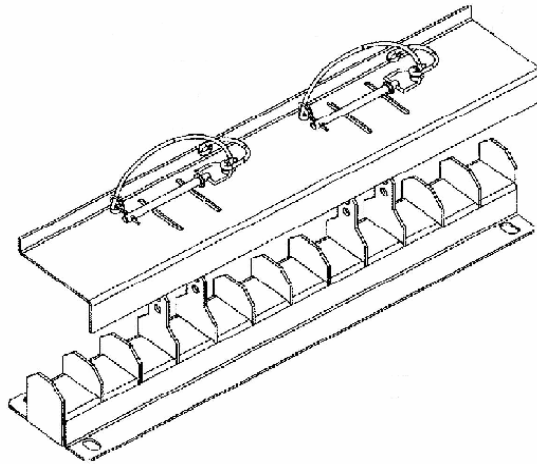

SERVICE

Wipe surfaces of EPC storage bracket (1), retainer pins with lanyards (2), and mount cap (3) to keep equipment clean.

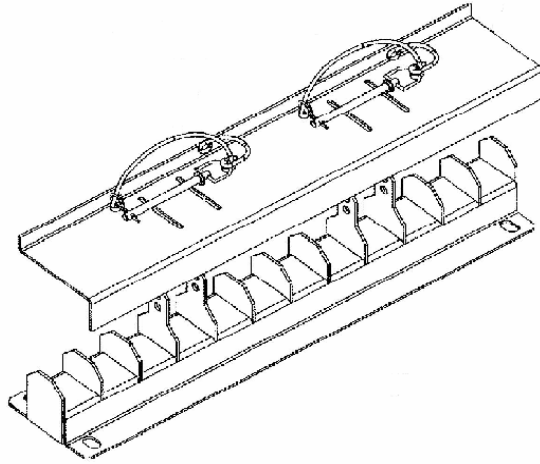
**REPAIR**

Repair pin and lanyard assembly as required.

REPLACE

1. Replace damaged or missing retainer pins or lanyards as required.
2. Replace damaged or missing mount cap if necessary.

END OF WORK PACKAGE

UNIT MAINTENANCE**AUTHORIZED STOCKAGE LIST MOBILITY SYSTEM (ASLMS)**

**MODEL NUMBER FPU-8/12 PARTS (OD) P/N 15005002-001
NSN 5411-01-523-2071**

**MODEL NUMBER FPU-8/12 PARTS (DS) P/N 15005002-002
NSN 5411-01-523-2072**

**MODEL NUMBER FPU-8/12 BULK (OD) P/N 15005001-001
NSN 5411-01-523-2073**

**MODEL NUMBER FPU-8/12 BULK (DS) P/N 15005001-002
NSN 5411-01-523-2074**

EPC

INSPECT, SERVICE, REPLACE

INITIAL SETUP:**Material/Parts**

Rags (Item 8, WP 0105 00)

Water

Personnel Required

Four

Tools

Ladder (Item 6, WP 0063 00)

References**Equipment Condition**

ASLMS set-up. EPC in place.

INSPECT

1. Inspect EPC (1) for dirt or debris.
2. Inspect EPC (1) covering for rips and/or tears. Notify direct support maintenance for repair.
3. Inspect EPC support bars (2) for bends, loose or missing hardware.
4. Inspect tent stake points (3), guy lines (4), and fastening straps (5) for rips and tears.
5. Inspect EPC poles for damaged or missing parts.
6. Inspect attachment points of the containers to include pins, davits, and struts.

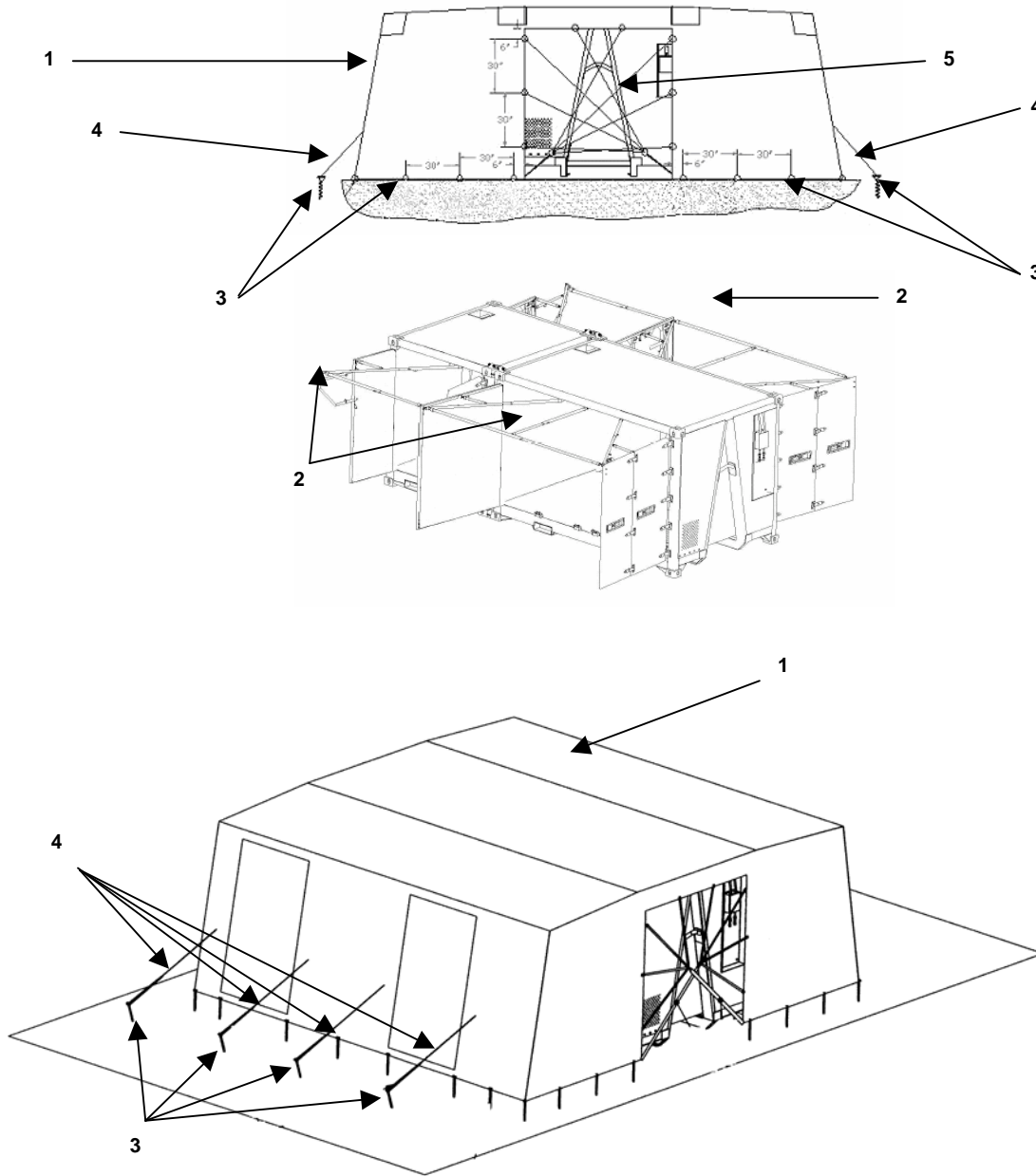

SERVICE

Wipe surfaces of EPC, support bars, and hardware as necessary to keep equipment clean.

REPLACE

Replace damaged or missing hardware (guy ropes, harnesses, stakes, and storage bag) as required.

END OF WORK PACKAGE

CHAPTER 6
DIRECT SUPPORT
MAINTENANCE INSTRUCTIONS

DIRECT SUPPORT MAINTENANCE

AUTHORIZED STOCKAGE LIST MOBILITY SYSTEM (ASLMS)

MODEL NUMBER FPU-8/12 PARTS (OD) P/N 15005002-001
NSN 5411-01-523-2071

MODEL NUMBER FPU-8/12 PARTS (DS) P/N 15005002-002
NSN 5411-01-523-2072

MODEL NUMBER FPU-8/12 BULK (OD) P/N 15005001-001
NSN 5411-01-523-2073

MODEL NUMBER FPU-8/12 BULK (DS) P/N 15005001-002
NSN 5411-01-523-2074

DOOR ASSEMBLIES

ALIGN, REPLACE, REPAIR

INITIAL SETUP:**Material/Parts**

Locktite 262 Red (Item 5, WP 0105 00)

References

WP 0006 00, WP 0049 00, TM 9-237

Personnel Required

Two

Equipment Condition

Doors open. Pallets/drawers removed.

Tools

General Mechanic's Tool Kit (Item 4, WP 0063 00)

Pinch Bar (Item 7, WP 0063 00)

Ladder (Item 6, WP 0063 00)

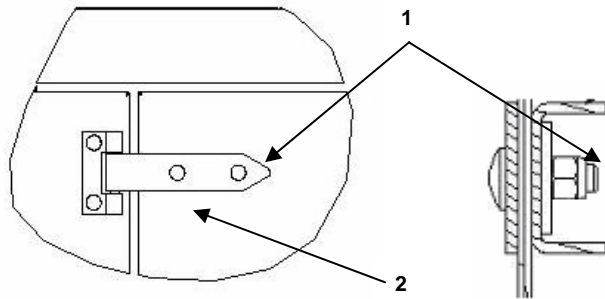
ALIGN**Align doors 2, 3, 8 and 9 as follows:**

1. Ensure that the container is on a level surface.
2. Remove drawers/pallets directly behind the door to be aligned. See WP 0006 00.
3. With door in the open position loosen hinge bolts on the door using a 9/16-inch socket with ratchet and wrench that the misaligned door is attached to. Do not loosen the bolts on the hinges that are on the misaligned door.
4. Close the misaligned door, leaving the opposite door open to allow access for measurements.
5. Using a pry bar, center door with equal distance from top of door edge to header and bottom door edge to threshold.

6. Retighten hinge bolts using a 9/16-inch socket with ratchet and wrench.
7. Reopen the door to be aligned.
8. Loosen the hinge bolts using a 9/16-inch socket with ratchet and wrench on the door that is being aligned. Do not loosen the hinge bolts on the door that the misaligned door is attached to.
9. Close the misaligned and opposite doors.
10. Retighten hinge bolts using a 9/16-inch socket with ratchet and wrench on the misaligned door.

Align doors 1, 4, 5, 6, 7, 10, 11 and 12 as follows:

1. Ensure that the container is on a level surface.
2. Remove drawers/pallets/modules directly behind the door to be aligned.
3. With door in the open position loosen hinge bolts on the door to be aligned using a 9/16-inch socket with ratchet and wrench. Do not loosen the bolts on the hinges attached to the misaligned door.
4. Close the misaligned door leaving the opposite door open to allow access for measurements.
5. Using a pry bar, center door with equal distance from top of door edge to header and bottom door edge to threshold.
6. Retighten hinge bolts using a 9/16-inch socket with ratchet and wrench.

REPLACE
Replacement of Door Hinge

1. Remove hinge bolts (1) using a 9/16-inch socket with ratchet and wrench, locknuts, and hinge (2) to be replaced.

NOTE

Replace only one hinge at a time to avoid alignment problems.

1. Applying Loctite 262 red to the bolt threads, reinstall bolts (1), and replacement hinge (2).
2. Check door operation, alignment, and align as required.

Replacement of Door Assembly

Refer to schematics, description, and parts required in WP 0049 00. The primary components are the hinges (1) carriage bolts (2) lock nuts (3) and seals.

BI-FOLD DOOR HARDWARE

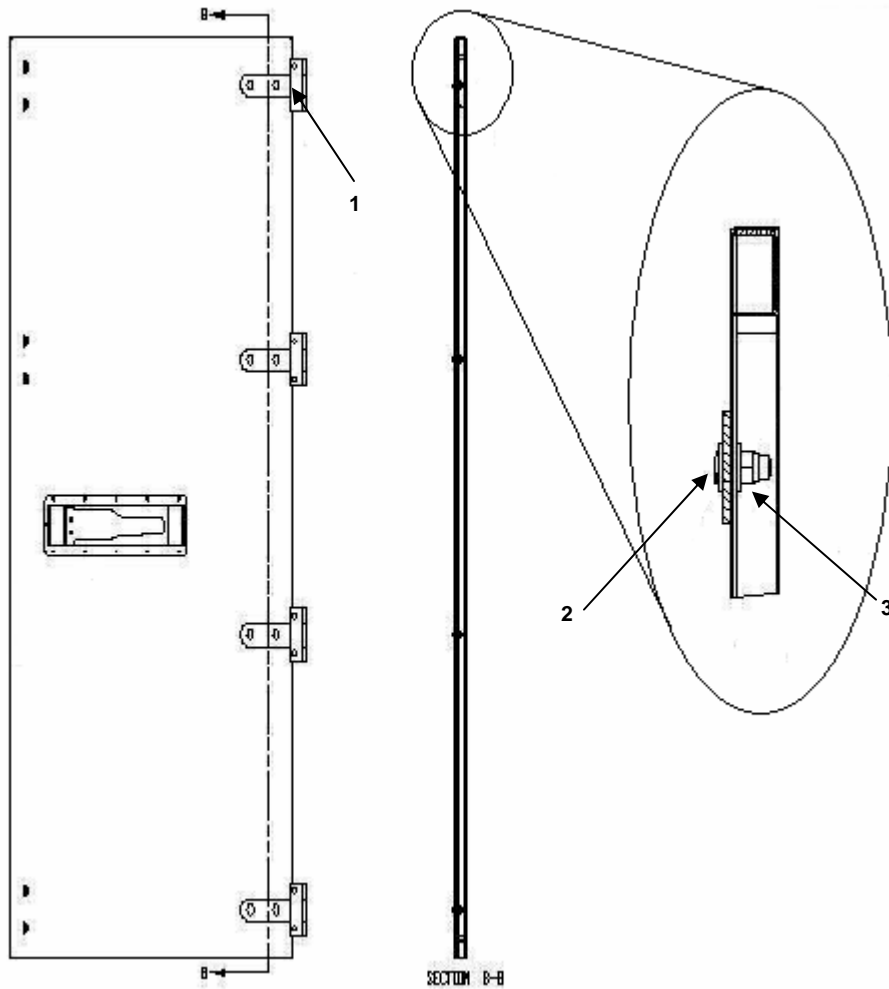

REPAIR



WARNING

When welding near CARC paint, be advised that vapors may be hazardous to health if inhaled. Wear proper protective clothing, mask and gear when performing this task.

Repairs Requiring Welding

Welding repairs are only required when the ASLMS container is pierced, punctured, or cracked. Standard welding principles and materials apply to ASLMS repairs. For welding procedures, refer to TM 9-237, Chapter 6.

END OF WORK PACKAGE

DIRECT SUPPORT

AUTHORIZED STOCKAGE LIST MOBILITY SYSTEM (ASLMS)

MODEL NUMBER FPU-8/12 PARTS (OD) P/N 15005002-001
NSN 5411-01-523-2071

MODEL NUMBER FPU-8/12 PARTS (DS) P/N 15005002-002
NSN 5411-01-523-2072

MODEL NUMBER FPU-8/12 BULK (OD) P/N 15005001-001
NSN 5411-01-523-2073

MODEL NUMBER FPU-8/12 BULK (DS) P/N 15005001-002
NSN 5411-01-523-2074

VERTICAL RACK FRAME

REPAIR, REPLACE

INITIAL SETUP:

Material/Parts

Locktite 262 Red (Item 6, WP 0150 00)

References

WP 0006 00, WP 0007 00 and TM 9-237

Personnel Required

Two

Equipment Condition

Doors open. Pallets/drawers removed.

Tools

Drill (Item 2, WP 0063 00)
General Mechanic's Tool Kit (Item 4, WP 0063 00)
Ladder (Item 6, WP 0063 00)
Rivnut Tool (Item 9, WP 0063 00)

REPAIR

Welding repairs are only required when the ASLMS container is pierced, punctured, or cracked. Standard welding principles and materials apply to ASLMS repairs. Refer to TM 9-237, Chapter 6, for welding procedures.

Drill out thread-damaged rivnuts in the rack frame (1) and install new rivnuts with the rivnut tool.

REPLACE

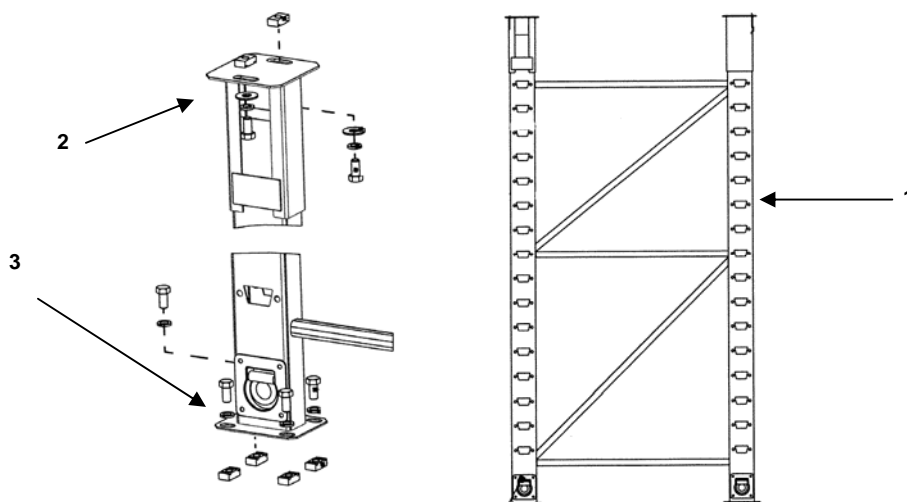

1. Remove all drawers/pallets, and drawer/pallet ledges that are attached to the vertical rack frame, to be replaced (refer to WP 0006 00 and WP 0007 00) for drawer and pallet ledge removal procedures).
2. Remove the 1/2-inch hex head bolts from the upper rack attachment assembly (2) and vertical rack frame base (3) using a 3/4-inch socket with ratchet.
3. Slide the rack upper attachment assembly down and remove vertical rack frame.
4. Insert the repaired/replacement vertical rack frame in the approximate position.
5. Attach upper attachment assembly (2) and vertical rack base (3) with 1/2-inch hex head bolts (Apply Locktite 262 to bolt threads). Hand-tighten only.
6. If the vertical rack frame is being installed on a pallet-configured container, use the pallet ledge stabilizer to obtain proper spacing by attaching, but not tightening, the stabilizer.
7. For parts configured container use the following table to obtain proper spacing:

30-Inch Drawers	29-7/8 Inches
48-Inch Drawers	47-5/8 Inches

8. Tighten all 1/2-inch bolts on the rack upper attachment (2) and vertical rack frame base (3) using a 3/4-inch socket with ratchet.
9. Reattach drawers/pallets to vertical rack frame (refer to WP 0006 00 and WP 0007 00) for drawer and pallet install procedures).

END OF WORK PACKAGE

DIRECT SUPPORT

AUTHORIZED STOCKAGE LIST MOBILITY SYSTEM (ASLMS)

MODEL NUMBER FPU-8/12 PARTS (OD) P/N 15005002-001
NSN 5411-01-523-2071

MODEL NUMBER FPU-8/12 PARTS (DS) P/N 15005002-002
NSN 5411-01-523-2072

MODEL NUMBER FPU-8/12 BULK (OD) P/N 15005001-001
NSN 5411-01-523-2073

MODEL NUMBER FPU-8/12 BULK (DS) P/N 15005001-002
NSN 5411-01-523-2074

DISTRIBUTION BOXES

REPLACE

INITIAL SETUP:

Material/Parts

Personnel Required

Two

Tools

Crimping Tool (Item 1, WP 0063 00)
General Mechanic's Tool Kit (Item 4, WP 0063 00)
Insertion/Extraction Tool (Item 5, WP 0063 00)

References

WP 0006 00, WP 0007 00

Equipment Condition

Doors open. Pallets/drawers removed.
Main breaker set to OFF position (cover of
distribution box is shown removed for clarity).

REPLACE

Replace distribution box "A" (1) as follows:

CAUTION

Although all personnel qualified to operate the ASLMS may connect electrical power using operating manual procedures, only qualified civilian (electrician), or qualified military personnel with MOS 51R, 52C, 52D, or 52G may perform maintenance on the electrical system.

1. Disconnect from power source.
2. Remove drawers/pallets to provide access to the area inside the container behind the distribution box (refer WP 0006 00).
3. Open distribution box.
4. Tag and disconnect all wires from the ground bar (2).

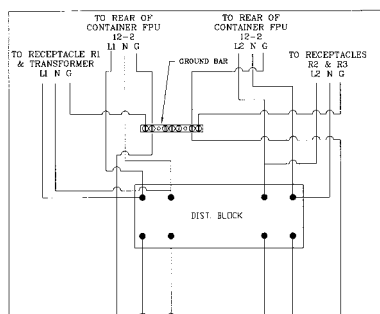

5. Remove all wires on the topside of the distribution box.
6. Remove internal nuts (3) that attach the conduit.
7. Remove the four 1/4" -20 x 1" distribution box securing screws (4).
8. Pull distribution box down and remove.
9. Attach new distribution box with the four 1/4" -20 x 1" securing screws (4).
10. Feed wires and conduit through holes located in the top of the distribution box.
11. Install and tighten conduit nuts (3).
12. Attach wires in accordance with the above illustration.
13. Close and secure distribution box cover.

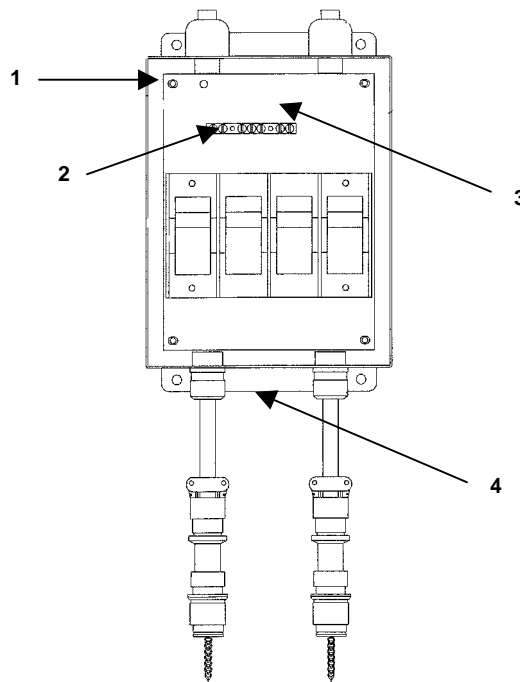

Replace distribution box "B" as follows:

1. Disconnect from power source.
2. Remove drawers/pallets/module to provide access to the area inside the container behind the distribution box (refer to WPs 0006 00 and 0007 00).
3. Open distribution box (1).
4. Tag (from left to right) L1 (4), DC (5), L2 (6) and cut wires closely next to the receptacles.
5. Remove internal nuts (2) that attach the conduit.

6. Remove the four 1/4" -20 x 1" distribution box securing screws (3).
7. Pull distribution box (1) down and remove.
8. Attach new distribution box (4) with the four 1/4" -20 x 1" securing screws (3).
9. Feed wires and conduit through holes located in the top of the distribution box (1).
10. Install and tighten conduit nuts (2).
11. Remove all receptacles (10) from the new distribution box (1) by removing the four #5 - 40 x 1/2-inch fillister head screws, (9) hex head nuts (8) and lock washers (7) using a flat head screw driver and 5/16-inch open end wrench.
12. Pull wires through the three openings in the bottom of the of the distribution box being careful to ensure that the marked wires are oriented as follows: From left to right L1(4) , DC (5) , L2 (6).
13. Strip insulation back 3/8-inch (10mm) on all wires using a stripper tool.

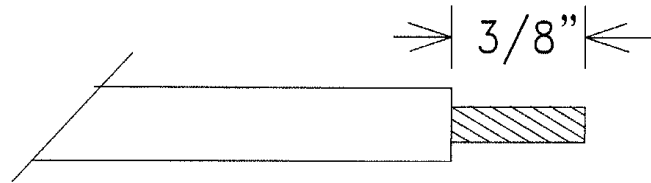

14. Insert stripped wire into female pin connector.

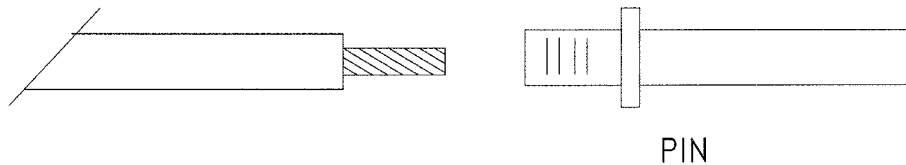

15. Using a type AF8 crimping tool with wire size setting 12 and depth setting yellow (12) at the end of the pin, crimp until the ratcheting action is released

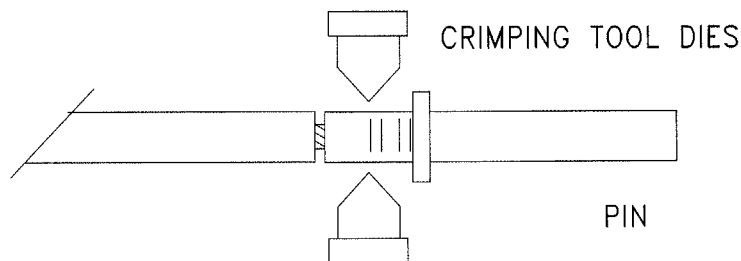

16. Using a pin insertion tool, slip the wire into insertion tool until pin shoulder is against the insertion tool.

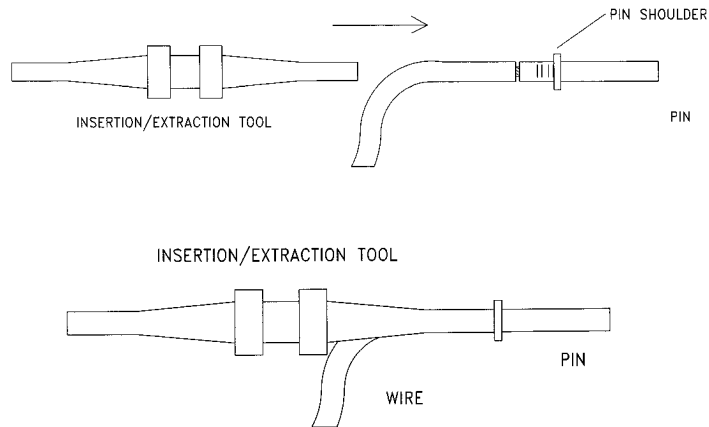

17. Slide wire and insertion tool into the connector (see table and illustration below for wire arrangement) until the pin shoulder is against the inner part of the connector.

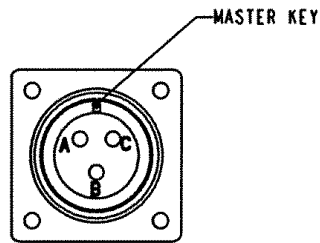

BLACK	A
WHITE	B
GREEN	C

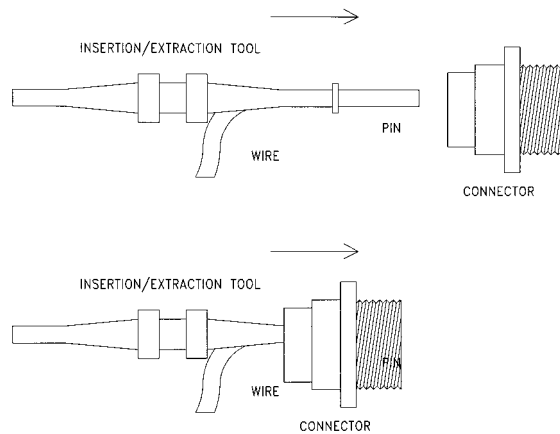

18. Slide out insertion tool.

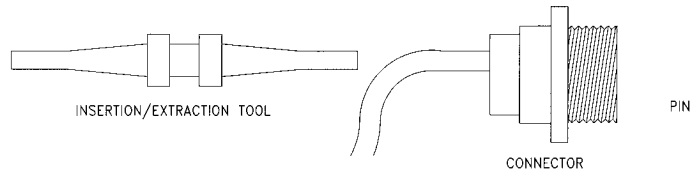

19. Following the same procedures in steps 12 and 17 to attach the wires marked L2 to sockets of the right female connector.

20. Using installation steps 3 through 7, connect DC wires (see table and illustration below for wire arrangement).

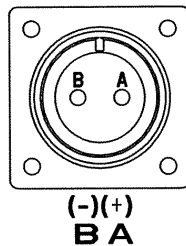

RED	A
BLACK	B

21. Reattach the female receptacles to the distribution box with the four #5 – 40 x 1/2-inch fillister head screws (8), hex head nuts (6) and lock washers (7) using a flat head screw driver and 5/16-inch open end wrench.

22. Verify electrical continuity for “from – to” path with an ohmmeter and remove tags.

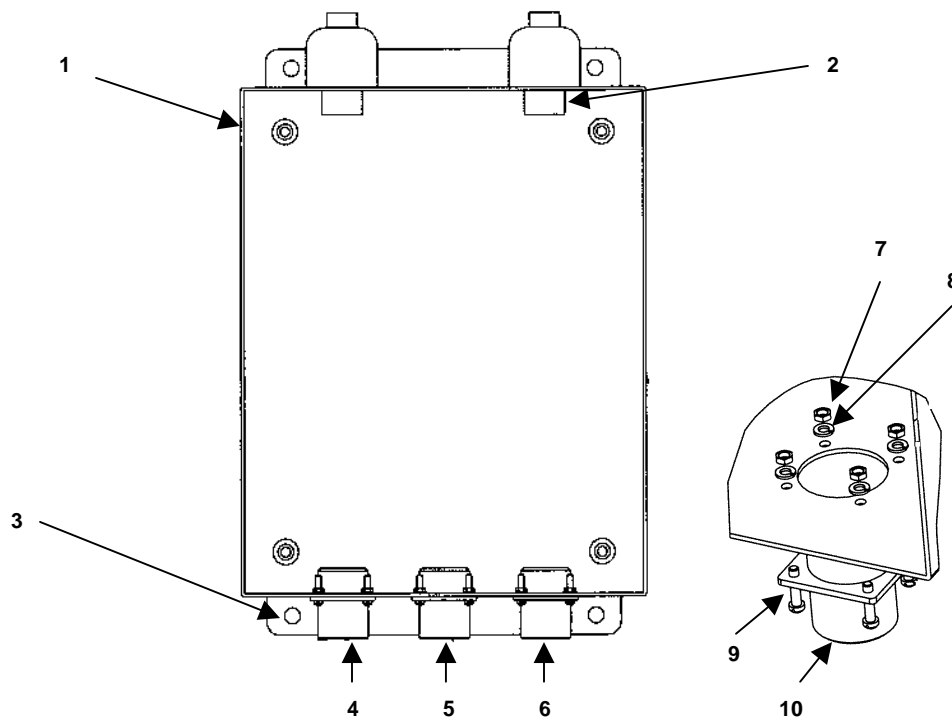

Replace distribution box “C” as follows:

1. Disconnect from power source.
2. Remove drawers/pallets/module to provide access to the area inside the container behind the distribution box (refer to WPs 0006 00 and 0007 00).
3. Open distribution box (1).
4. Tag (from left to right) L1 (4), L2 (5) and cut wires closely next to the receptacles (9).
5. Remove internal nuts (3) that attach the conduit.
6. Remove the four 1/4" –20 x 1" distribution box securing screws (2).
7. Pull distribution box (1) down and remove.
8. Attach new distribution box with the four 1/4" –20 x 1" securing screws (2).
9. Feed wires and conduit through holes located in the top of the distribution box (1).
10. Install and tighten conduit nuts (3).
11. Remove all receptacles (9) from the new distribution box (1) by removing the four #5 – 40 x 1/2-inch fillister head screws (8), hex head nuts (6) and lock washers (7) using a flat head screw driver and 5/16-inch open end wrench.
12. Pull wires through the two openings in the bottom of the of the distribution box (1) being careful to ensure that the marked wires are oriented as follows: From left to right L1 (4), L2 (5).
13. Strip insulation back 3/8-inch (10mm) on all wires using a stripper tool.

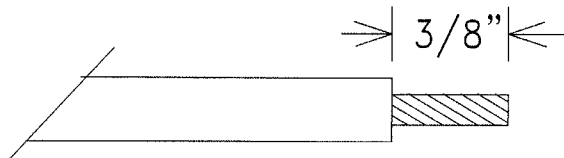

14. Slip stripped wire into female pin connector.

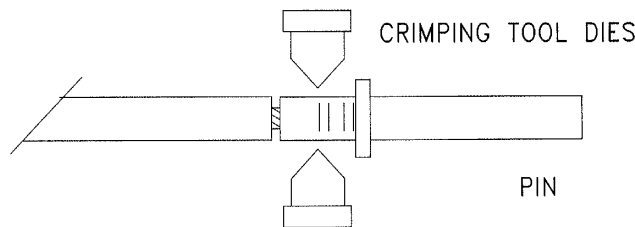

15. Using a type AF8 crimping tool with wire size setting 12 and depth setting yellow (12) at the end of the pin, crimp until the ratcheting action is released

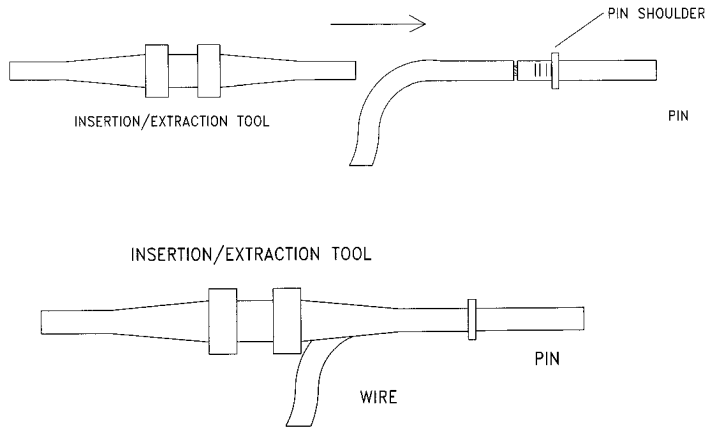

16. Using a pin insertion tool, slip the wire into insertion tool until pin shoulder is against the insertion tool.

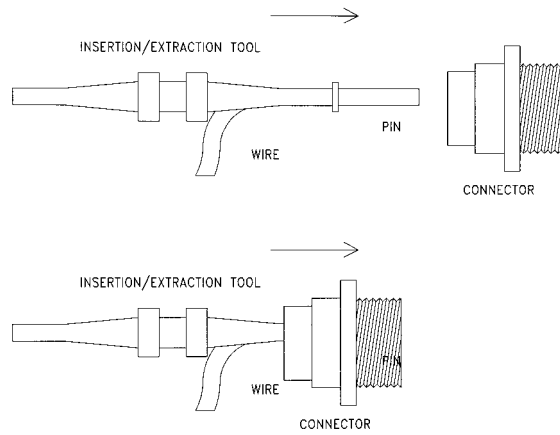

17. Slide wire and insertion tool into the connector (see table and illustration below for wire arrangement) until the pin shoulder is against the inner part of the connector.

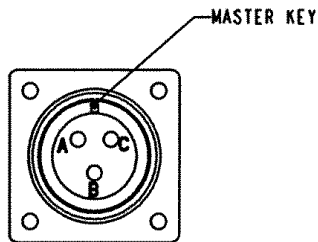

BLACK	A
WHITE	B
GREEN	C

18. Slide out insertion tool.

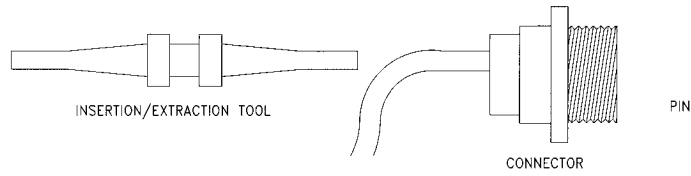

19. Following the same procedures in steps 13 and 17 to attach the wires marked L2 (5) to sockets of the right female connector.

20. Reattach the female receptacles (9) to the distribution box (1) with the four #5 – 40 x 1/2-inch fillister head screws, (8) hex head nuts (6) and lock washers (7) using a flat head screw driver and 5/16-inch open end wrench.

21. Verify electrical continuity for “from – to” path with an ohmmeter and remove tags.

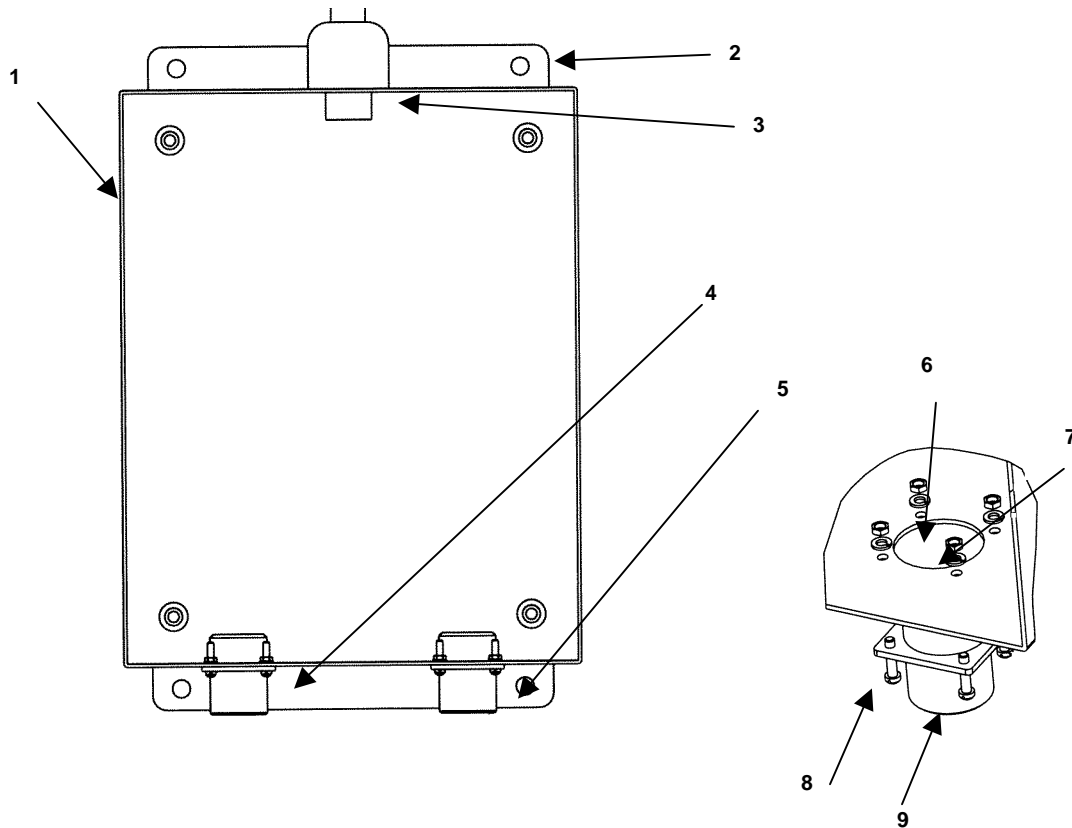

END OF WORK PACKAGE

AUTHORIZED STOCKAGE LIST MOBILITY SYSTEM (ASLMS)

**MODEL NUMBER FPU-8/12 PARTS (OD) P/N 15005002-001
NSN 5411-01-523-2071**
**MODEL NUMBER FPU-8/12 PARTS (DS) P/N 15005002-002
NSN 5411-01-523-2072**
**MODEL NUMBER FPU-8/12 BULK (OD) P/N 15005001-001
NSN 5411-01-523-2073**
**MODEL NUMBER FPU-8/12 BULK (DS) P/N 15005001-002
NSN 5411-01-523-2074**

TRANSFORMER

TEST, REPLACE

INITIAL SETUP:

Material/Parts

Electrical Tape (Item 2, WP 0105 00)

References

WP 0006 00

Personnel Required

One

Equipment Condition

Doors open. Module, pallets/drawers removed.
Power disconnected. PDISE main breaker set
to OFF position.

Tools

General Mechanic's Tool Kit (Item 4, WP 0063 00)

TEST

1. Disconnect from power source.
2. Remove drawers/pallets under transformer enclosure to provide access (refer to WP 0006 00).
3. Remove cover (3) of transformer enclosure (1) by loosening 4 cover retention screws (6).
4. Reconnect to power source.
5. Using the multi-meter, test for incoming AC power (Black, White and Green wires at the top left hand corner of the transformer).
6. Using the multi-meter, test for DC power output (Black and White wires at the bottom of the transformer marked positions 5 and 6).
7. If there is incoming AC power but no DC power output replace the transformer.

REPLACE**WARNING**

Electrical power must be disconnected before any electrical system work is performed to prevent electrical shock, injury, or death (electrocution). Only trained and qualified personnel (MOS 51R, 52C, 52E, or 52G) may perform maintenance or attempt to correct electrical discrepancies on the electrical system.

1. Disconnect from power source.
2. Remove drawers/pallets under transformer enclosure to provide access (refer to WP 0006 00).
3. Remove cover (3) of transformer enclosure (1) by loosening 4 cover retention screws (6).
4. Disconnect the black (L), white (N) and green (G) 120V input wires.
5. Tag and disconnect the black and white DC output wires.
6. Remove the six M4 – 6 Philips pan head screws and pull out the transformer and backing plate.
7. Remove transformer attaching on the backside of the backing plate (2) and remove transformer (4).
8. Attach the new transformer (4) to the backing plate (2) with the 4 M4 – 6 Philips pan head screws.
9. Attach transformer to the transformer enclosure with the 6 M4 – 6 Philips pan head screws (5).

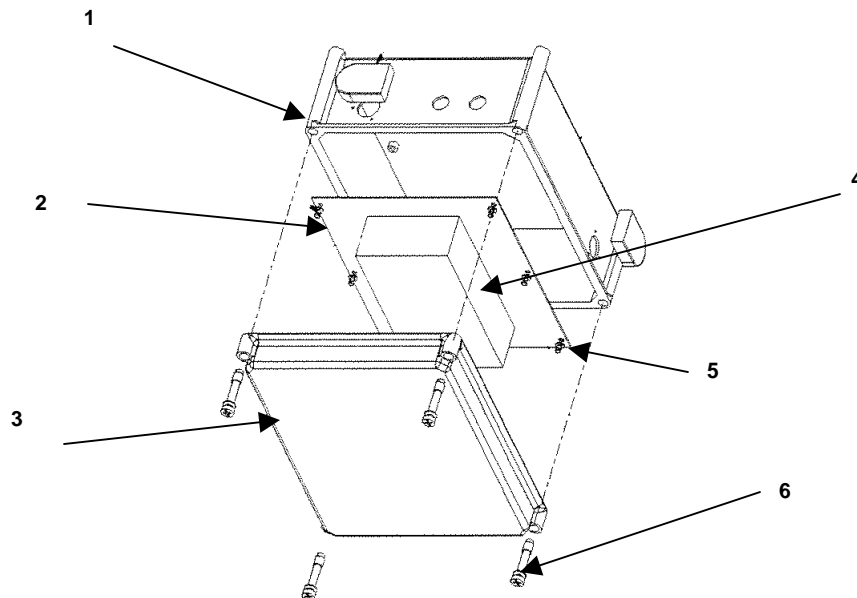

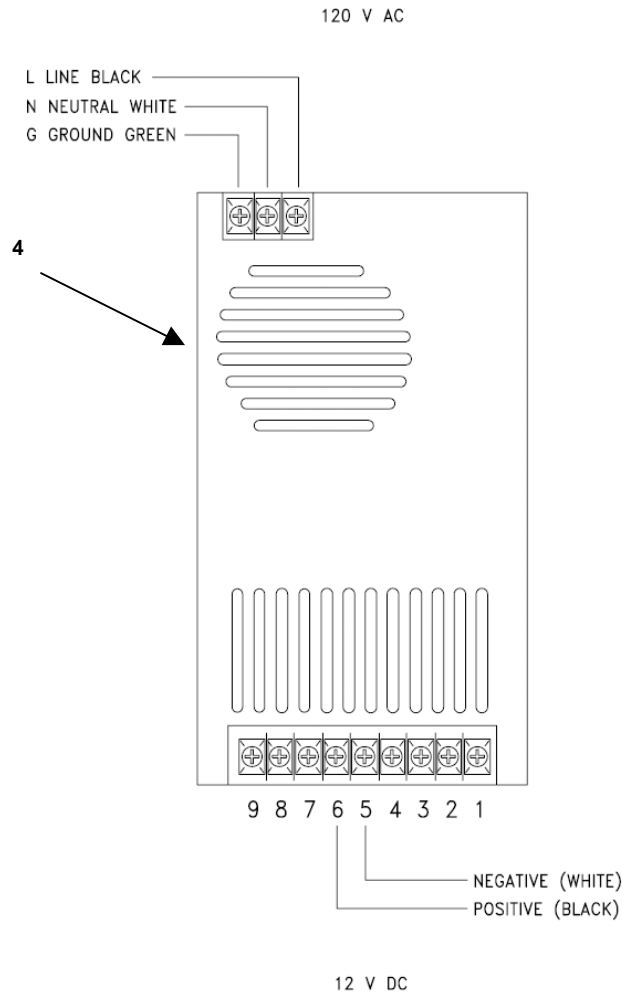

- 10. Reconnect wires and remove tags in accordance with the above illustration.
- 11. Reinstall cover to transformer enclosure.

END OF WORK PACKAGE

DIRECT SUPPORT**AUTHORIZED STOCKAGE LIST MOBILITY SYSTEM (ASLMS)**

**MODEL NUMBER FPU-8/12 PARTS (OD) P/N 15005002-001
NSN 5411-01-523-2071**

**MODEL NUMBER FPU-8/12 PARTS (DS) P/N 15005002-002
NSN 5411-01-523-2072**

**MODEL NUMBER FPU-8/12 BULK (OD) P/N 15005001-001
NSN 5411-01-523-2073**

**MODEL NUMBER FPU-8/12 BULK (DS) P/N 15005001-002
NSN 5411-01-523-2074**

12-VOLT LIGHT ASSEMBLY

TEST, REPAIR

INITIAL SETUP:**Material/Parts**

Electrical Tape (Item 2, WP 0105 00)

References

WP 0054 00

Personnel Required

One

Equipment Condition

Doors open. Modules, drawers/pallets removed. Power disconnected. PDISE breakers set to OFF position.

Tool

General Mechanic's Tool Kit (Item 4, WP 0063 00)
Ladder (Item 6, WP 0063 00)

TEST**NOTE**

Ensure test of the transformer (refer to WP 0054 00) has been performed and no problems noted prior to initiating the following steps.

1. Disconnect from power source.
2. Open light storage box (2) and remove light assembly (1).
3. Remove cover to light junction box (3) located inside the light storage box (2) by removing the 2 screws.
4. Reconnect to power source.
5. Using a multi-meter, check for 12V DC power at the wire nut connections (white is positive and black is negative) and the light sock.
6. If power test positive at the junction box but not at the light socket replace the light fixture.

REPAIR

**WARNING**

Electrical power must be disconnected before any electrical system work is performed to prevent electrical shock, injury, or death (electrocution). Only trained and qualified personnel (MOS 51R, 52C, 52E, or 52G) may perform maintenance or attempt to correct electrical discrepancies on the electrical system.

1. Disconnect from power source.
2. Open light storage box (2) and remove light assembly (1).
3. Remove cover to light junction box (3) located inside the light storage box (2) by removing the 2 screws.
4. Remove electrical tape from the wire nuts.
5. Remove wire nuts that connect the white and black wires.
6. Loosen the 15/16-inch nut on the cord grip.
7. Pull cord (4) out of the junction box (3).
8. Remove old light.
9. Feed cord (4) of the new light through the cord grip.
10. Tighten the 15/16-inch nut on the cord grip.
11. Using wire nuts, reconnect the white and black wires.
12. Wrap electrical tape over wire nuts to properly secure the electrical connections.
13. Reinstall junction box cover by inserting the 2 screws.
14. Re-stow the light in the light storage box.

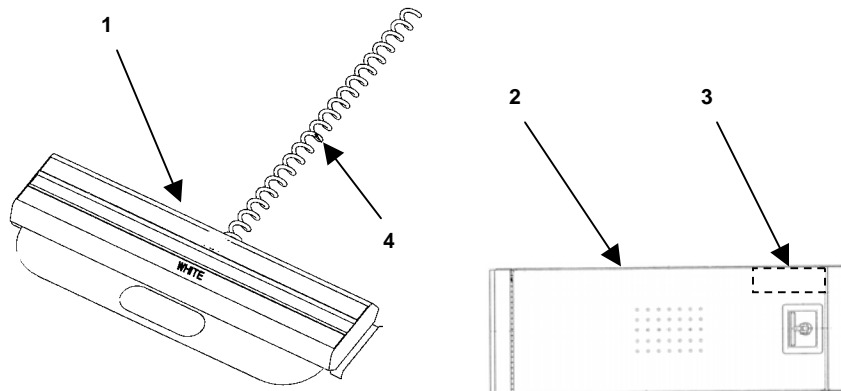

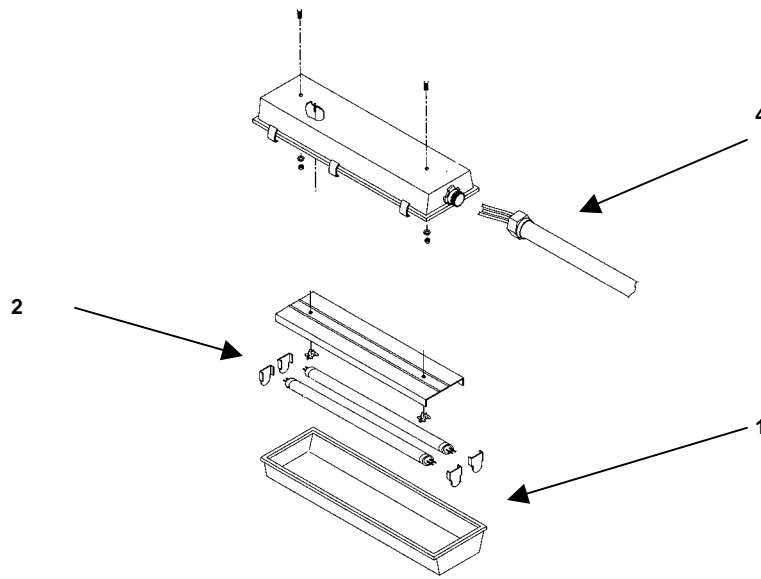

END OF WORK PACKAGE

DIRECT SUPPORT**AUTHORIZED STOCKAGE LIST MOBILITY SYSTEM (ASLMS)**

**MODEL NUMBER FPU-8/12 PARTS (OD) P/N 15005002-001
NSN 5411-01-523-2071**

**MODEL NUMBER FPU-8/12 PARTS (DS) P/N 15005002-002
NSN 5411-01-523-2072**

**MODEL NUMBER FPU-8/12 BULK (OD) P/N 15005001-001
NSN 5411-01-523-2073**

**MODEL NUMBER FPU-8/12 BULK (DS) P/N 15005001-002
NSN 5411-01-523-2074**

DOOR SEALS

INSPECT, SERVICE, REPLACE

INITIAL SETUP:**Material/Parts**

Oil, Lubricating (Item 6, WP 0105 00)
Rags (Item 8, WP 0105 00)

References

WP 0017 00

Personnel Required

One

Equipment Condition

Doors open.

Tools

Drill (Item 2, WP 0063 00)
Drill Bit 3/16" (Item 3, WP 0063 00)
General Mechanic's Tool Kit (Item 4, WP 0063 00)
Ladder (Item 6, WP 0063 00)
Pinch Bar (Item 7, WP 0063 00)
Riveting Tool (Item 8, WP 0063 00)

INSPECT

Inspect seals for rips, cuts, leaks and missing or detached seal pieces. Report problems to direct support maintenance.

SERVICE

1. Clean seals with damp and dry rags.
2. Lubricate as necessary (refer to WP 0017 00).

REPLACE

1. Drill out rivets of the seal that is to be replaced using a 3/16-inch drill bit.
2. Use a pry bar or large scraper to remove old seals (1, 2, 3, 4, 5, 6, and 7).
3. Use a scraper to remove adhesive.
4. Using the appropriate seal replacement kit for the door of the seal to be replaced, apply SEALOK sealant to the inside of the door seals.
5. Press door seals (1 through 4) in the proper position.
6. Using a 3/16-inch drill bit, drill holes through the seal and door edge. Four evenly distributed along the top and bottom and eight along the two sides.
7. Attach using 3/16-inch closed end rivets.
8. Using tab adhesive attach the door seal corners (7).
9. Using tab adhesive attach the inside and outside corner tabs (5) and (6).

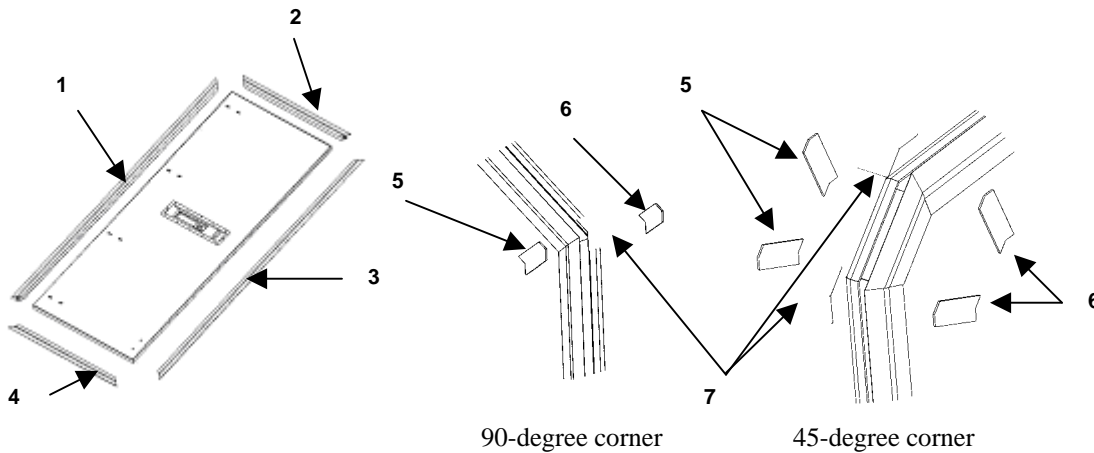
**END OF WORK PACKAGE**

DIRECT SUPPORT

AUTHORIZED STOCKAGE LIST MOBILITY SYSTEM (ASLMS)

MODEL NUMBER FPU-8/12 PARTS (OD) P/N 15005002-001
NSN 5411-01-523-2071

MODEL NUMBER FPU-8/12 PARTS (DS) P/N 15005002-002
NSN 5411-01-523-2072

MODEL NUMBER FPU-8/12 BULK (OD) P/N 15005001-001
NSN 5411-01-523-2073

MODEL NUMBER FPU-8/12 BULK (DS) P/N 15005001-002
NSN 5411-01-523-2074

CABLE A/C

REPAIR

INITIAL SETUP:

Material/Parts

References

Personnel Required

One

Equipment Condition

Cable removed and disconnected from power source. PDISE breakers set to OFF position.

Tools

- Crimping Tool (Item 1, WP 0063 00)
- General Mechanic's Tool Kit (Item 4, WP 0063 00)
- Insertion/Extraction Tool (Item 5, WP 0063 00)
- Ladder (Item 6, WP 0063 00)

REPAIR

CAUTION

Although all personnel qualified to operate the ASLMS may connect electrical power using operating manual procedures, only qualified civilian (electrician), or qualified military personnel with MOS 51R, 52C, 52D, or 52G may perform maintenance on the electrical system.

1. Disconnect from power source.
2. Remove receptacle to be replaced.

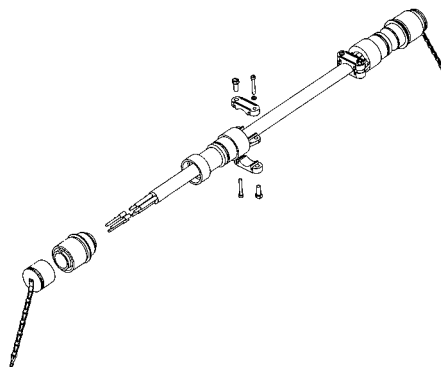

3. Re-strip insulation back 3/8-inch (10mm) on all three wires using a stripper tool if necessary.

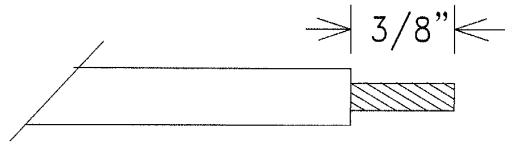

4. Insert stripped wire into male pin connector.

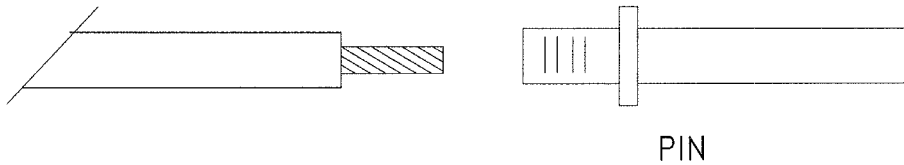

5. Using a type AF8 crimping tool with wire size setting 12 and depth setting yellow (12) at the end of the pin, crimp until the ratcheting action is released

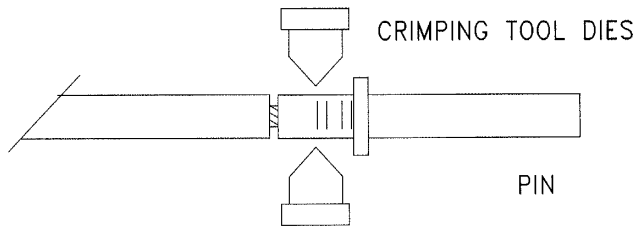

6. Using a pin insertion tool, slip the wire into insertion tool until pin shoulder is against the insertion tool.

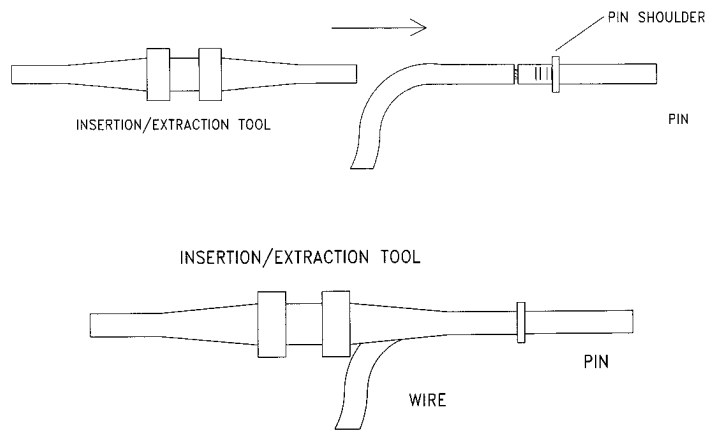

- Slide wire and insertion tool into the connector (see table and illustration below for wire arrangement) until the pin shoulder is against the inner part of the connector.

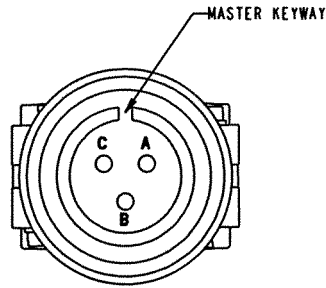

BLACK	A
WHITE	B
GREEN	C

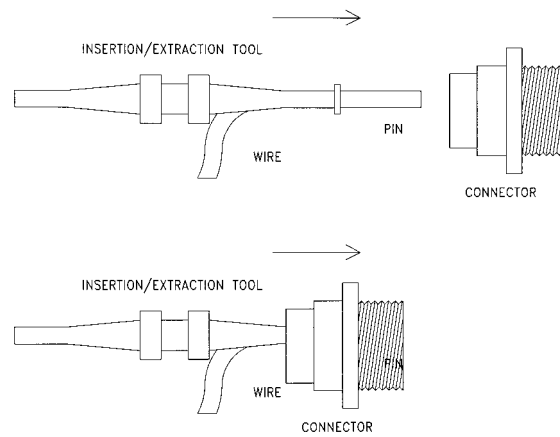

- Slide out insertion tool.

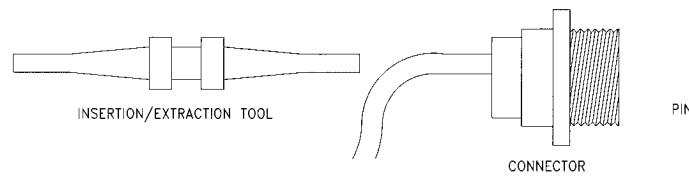

- Follow the same procedures in steps 4 through 8 to attach pins to the other wires and to the connector.
- Verify electrical continuity for "from – to" path with an ohmmeter

END OF WORK PACKAGE

DIRECT SUPPORT

AUTHORIZED STOCKAGE LIST MOBILITY SYSTEM (ASLMS)

MODEL NUMBER FPU-8/12 PARTS (OD) P/N 15005002-001
NSN 5411-01-523-2071

MODEL NUMBER FPU-8/12 PARTS (DS) P/N 15005002-002
NSN 5411-01-523-2072

MODEL NUMBER FPU-8/12 BULK (OD) P/N 15005001-001
NSN 5411-01-523-2073

MODEL NUMBER FPU-8/12 BULK (DS) P/N 15005001-002
NSN 5411-01-523-2074

CABLE D/C

REPAIR

INITIAL SETUP:

Material/Parts

References

Personnel Required

One

Equipment Condition

Cable removed and disconnected from power source. PDISE main breaker set to OFF position.

Tools

Crimping Tool (Item 1, WP 0063 00)
General Mechanic's Tool Kit (Item 4, WP 0063 00)
Ladder (Item 6, WP 0063 00)

REPAIR

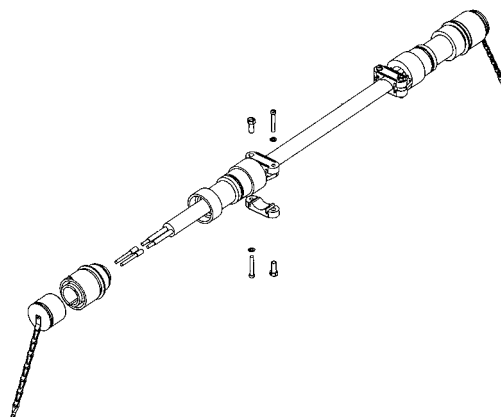
**CAUTION**

Although all personnel qualified to operate the ASLMS may connect electrical power using operating manual procedures, only qualified civilian (electrician), or qualified military personnel with MOS 51R, 52C, 52D, or 52G may perform maintenance on the electrical system.

1. Disconnect from power source.
2. Remove receptacle to be replaced.

3. Re-strip insulation back 3/8-inch (10mm) on all three wires using a stripper tool if necessary.

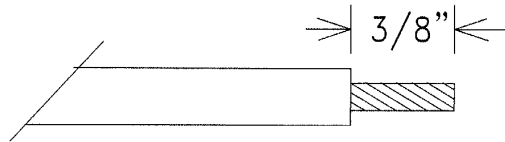

4. Insert stripped wire into male pin connector.

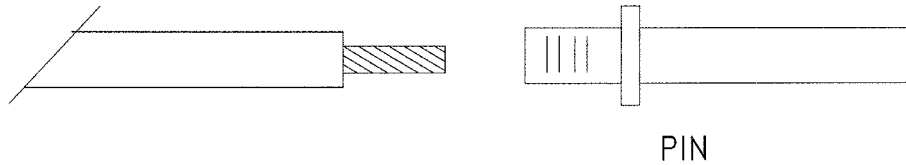

5. Using a crimping tool with wire size setting 12 and depth setting yellow (12) at the end of the pin, crimp until the ratcheting action is released

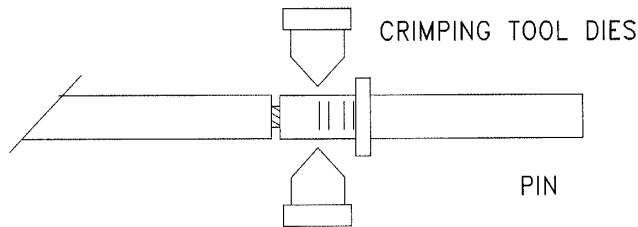

6. Using a pin insertion tool, slip the wire into insertion tool until pin shoulder is against the insertion tool.

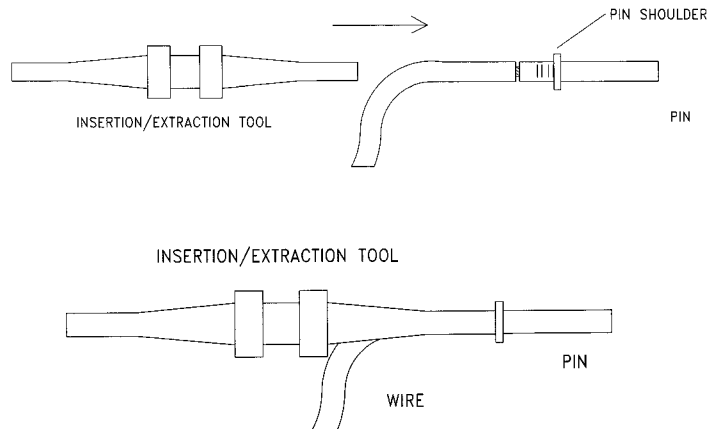

- Slide wire and insertion tool into the connector (see table and illustration below for wire arrangement) until the pin shoulder is against the inner part of the connector.

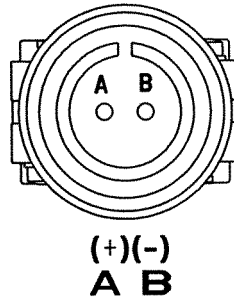

BLACK	A
WHITE	B
GREEN	C

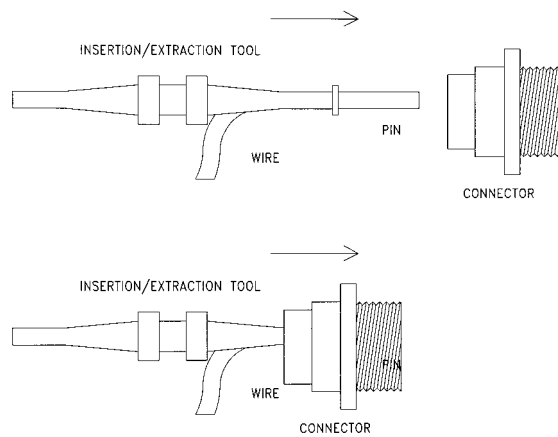

- Slide out insertion tool.

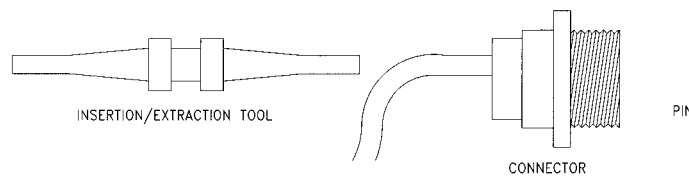

- Follow the same procedures in steps 4 through 8 to attach pins to the other wires and to the connector.
- Verify electrical continuity for "from – to" path with an ohmmeter

END OF WORK PACKAGE

DIRECT SUPPORT

AUTHORIZED STOCKAGE LIST MOBILITY SYSTEM (ASLMS)

MODEL NUMBER FPU-8/12 PARTS (OD) P/N 15005002-001
NSN 5411-01-523-2071

MODEL NUMBER FPU-8/12 PARTS (DS) P/N 15005002-002
NSN 5411-01-523-2072

MODEL NUMBER FPU-8/12 BULK (OD) P/N 15005001-001
NSN 5411-01-523-2073

MODEL NUMBER FPU-8/12 BULK (DS) P/N 15005001-002
NSN 5411-01-523-2074

EPC ASSEMBLY

REPAIR

INITIAL SETUP:

Material/Parts

References

Personnel Required

One

Equipment Condition

EPC deployed.

Tools

Ladder (Item 6, WP 0063 00)

REPAIR

Repair any reported rips/tears to EPC (1) as reported, using standard Army tent repair procedures (1).

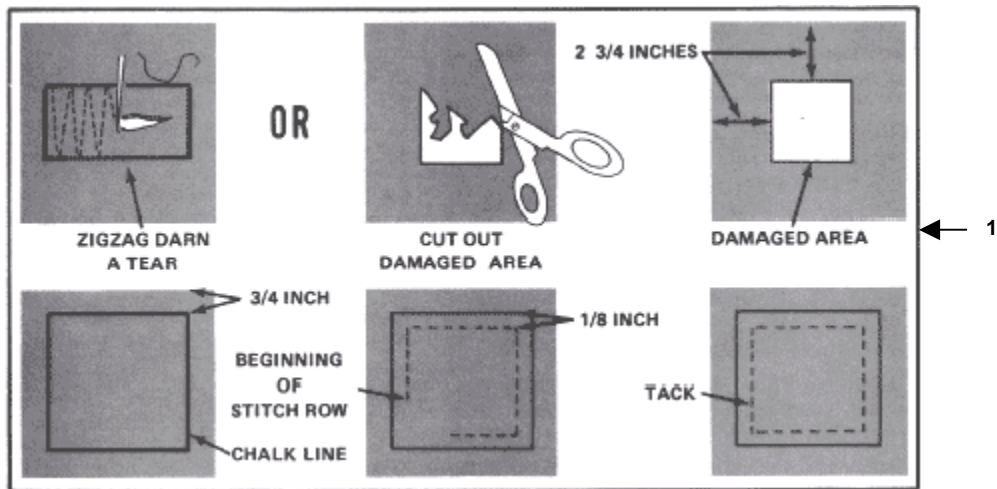

END OF WORK PACKAGE

DIRECT SUPPORT

AUTHORIZED STOCKAGE LIST MOBILITY SYSTEM (ASLMS)

MODEL NUMBER FPU-8/12 PARTS (OD) P/N 15005002-001
NSN 5411-01-523-2071

MODEL NUMBER FPU-8/12 PARTS (DS) P/N 15005002-002
NSN 5411-01-523-2072

MODEL NUMBER FPU-8/12 BULK (OD) P/N 15005001-001
NSN 5411-01-523-2073

MODEL NUMBER FPU-8/12 BULK (DS) P/N 15005001-002
NSN 5411-01-523-2074

PALLET LEDGE

REPAIR

INITIAL SETUP:

Material/Parts

References

TM 9-237

Personnel Required

Equipment Condition

One

Pallet removed.

Tools

Drill (Item 2, WP 0063 00)

Drill Bit 3/16" (Item 3, WP 0063 00)

General Mechanic's Tool Kit (Item 4, WP 0063 00)

REPAIR

Welding repairs are only required when the pallet is cracked. Standard welding principles and materials apply to ASLMS repairs. Welding procedures will not be discussed in this manual. Refer to TM 9-237, Chapter 6 for welding procedures.

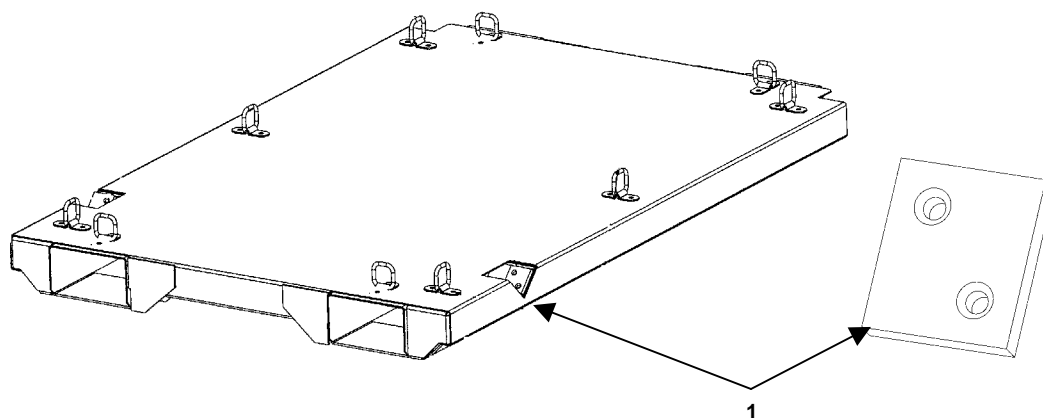

Pallet Locking Pad

1. Using a drill and size 3/16-inch drill bit, drill out the rivets that attach the pad (1) to be replaced.
2. Remove old lock pad (1).

3. Align new lock pad (1) with the pallet holes being careful to position the pad with the recessed holes to the outside.
4. Attach the pad using two 3/16-inch steel rivets.

END OF WORK PACKAGE

CHAPTER 7
SUPPORTING INFORMATION

OPERATOR, UNIT, AND DIRECT SUPPORT MAINTENANCE**AUTHORIZED STOCKAGE LIST MOBILITY SYSTEM (ASLMS)****MODEL NUMBER FPU-8/12 PARTS (OD) P/N 15005002-001****NSN 5411-01-523-2071****MODEL NUMBER FPU-8/12 PARTS (DS) P/N 15005002-002****NSN 5411-01-523-2072****MODEL NUMBER FPU-8/12 BULK (OD) P/N 15005001-001****NSN 5411-01-523-2073****MODEL NUMBER FPU-8/12 BULK (DS) P/N 15005001-002****NSN 5411-01-523-2074****REFERENCES****SCOPE**

This work package lists field manuals, forms, technical manuals, pamphlets and miscellaneous publications that are referenced in this manual or are otherwise applicable to the operation and maintenance of the ASLMS.

FIELD MANUALS

First Aid for Soldiers	FM 21-11
Theater of Operations Electrical Systems	FM 5-424
Basic Cold Weather Manual	FM 31-70
Chemical and Biological Contamination Avoidance	FM 3-3
NBC Protection	FM 3-4
NBC Decontamination	FM 3-5
General Repair of Tents, Canvas, and Webbing	FM 10-16

FORMS

Equipment Control Record	DA Form 2408-9
Equipment Inspection and Maintenance Worksheet	DA Form 2404
Hand Receipt/Annex Human	DA Form 2062
Product Quality Deficiency Report	SF 368
Recommended Changes to Publications and Blank Forms	DA Form 2028
Recommended Changes to Equipment Technical Publications	DA Form 2028-2
Transportation Discrepancy Report	SF 361

TECHNICAL MANUALS

Destruction of Army Equipment to Prevent Enemy Use (Mobility Equipment Command)	TM 750-244-3
Administrative Storage of Equipment	TM 740-90-1
Preservation, Packaging, and Packing of Military Supplies and Equipment	TM 38-230-2
Welding Theory and Application	TM 9-237
Metal Body Repair and Related Operation	TM 9-510
Operator's Manual for Generator Set, Skid Mounted, Tactical Quiet	TM 9-6115-642-10
Unit, Direct Support and General Support Maintenance Manual for Generator Set, Skid Mounted, Tactical Quiet	TM 9-6115-642-24
Facility Engineering Electrical Facility Safety	TM 5-682

PAMPHLETS

Functional User's Manual for the Army Maintenance Management System (TAMMS)	DA PAM 738-750
---	----------------

MISCELLANEOUS PUBLICATIONS

Occupational and Environmental Health Food Service

TB MED 530

Lubrication Order

LO 9-6115-642-12

Common Table of Allowances, Expendable/Durable Items

CTA 50-970

Common Table of Allowances, Army Medical Department Expendable/Durable Items

CTA 8-100

END OF WORK PACKAGE

OPERATOR, UNIT, AND DIRECT SUPPORT MAINTENANCE**AUTHORIZED STOCKAGE LIST MOBILITY SYSTEM (ASLMS)****MODEL NUMBER FPU-8/12 PARTS (OD) P/N 15005002-001****NSN 5411-01-523-2071****MODEL NUMBER FPU-8/12 PARTS (DS) P/N 15005002-002****NSN 5411-01-523-2072****MODEL NUMBER FPU-8/12 BULK (OD) P/N 15005001-001****NSN 5411-01-523-2073****MODEL NUMBER FPU-8/12 BULK (DS) P/N 15005001-002****NSN 5411-01-523-2074**

MAINTENANCE ALLOCATION CHART (MAC) INTRODUCTION

INTRODUCTION**The Army Maintenance System MAC**

This introduction provides a general explanation of all maintenance and repair functions authorized at various maintenance levels under the standard Army Maintenance System concept.

The MAC (WP 0062 00, Table 1, immediately following the introduction) designates overall authority and responsibility for the performance of maintenance functions on the ASLMS. The application of the maintenance functions to the ASLMS shall be consistent with the capacities and capabilities of the designated maintenance levels, which are shown on the MAC in column (4) as:

Unit – includes two sub columns, C (operator/crew) and O (unit) maintenance.

Direct Support – includes an F sub column.

General Support – includes an H sub column.

Depot – includes a D sub column.

The tools and test equipment requirements (WP 0062 00, Table 2, immediately following the MAC) list the tools and test equipment (both special tools and common tool sets) required for each maintenance function as referenced from the MAC.

The remarks (WP 0062 00, Table 3, immediately following the tools and test equipment requirements) contain supplemental instructions and explanatory notes for a particular maintenance function.

Maintenance Functions

Maintenance functions are limited to and defined as follows:

1. **Inspect:** To determine the serviceability of an item by comparing its physical, mechanical, and/or electrical characteristics with established standards through examination (e.g., by sight, sound, or feel). This includes scheduled inspections.
2. **Test:** To verify serviceability by measuring the mechanical, pneumatic, hydraulic, or electrical characteristics of an item and comparing those characteristics with prescribed standards on a scheduled basis, i.e., load testing of lift devices and hydrostatic testing of pressure hoses.
3. **Service:** Operations required periodically to keep an item in proper operating condition; e.g., to clean (includes decontaminate, when required), to preserve, to drain, to paint, or to replenish fuel, lubricants, chemical fluids, or gases.
4. **Adjust:** To maintain or regulate, within prescribed limits, by bringing into proper position, or by setting the operating characteristics to specific parameters.

5. **Align:** To adjust specified variable elements of an item to bring about optimum or desired performance.
6. **Calibrate:** To determine and cause corrections to be made or to be adjusted on instruments of test, measuring, and diagnostic equipment used in precision measurement. Consists of comparisons of two instruments, one of which is a certified standard of known accuracy, to detect and adjust any discrepancy in the accuracy of the instrument being compared.
7. **Remove/Install:** To remove and install the same item when required to perform service or other maintenance functions. Install may be the act of emplacing, seating, or fixing into position a spare, repair part, or module (component or assembly) in a manner to allow the proper functioning of an equipment or system.
8. **Replace:** To remove an unserviceable item and install a serviceable counterpart in its place. "Replace" is authorized by the MAC and assigned maintenance level is shown as the third position code of the Source, Maintenance and Recoverability (SMR) code.
9. **Repair:** The application of maintenance services, including fault location/troubleshooting, removal/installation, disassembly/assembly procedures, and maintenance actions to identify troubles and restore serviceability to an item by correcting specific damage, fault, malfunction, or failure in a part, subassembly, module (component or assembly), end item, or system.

NOTE

The following definitions are applicable to the "REPAIR" maintenance functions of Service, Inspect, Test, Adjust, Align, Calibrate, and/or Replace:

Fault location/troubleshooting – The process of investigating and detecting the cause of equipment malfunctioning; the act of isolating a fault within a system or Unit Under Test (UUT).

Disassembly/Assembly – The step-by-step breakdown (taking apart) of a spare/functional group coded item to the level of its least component, that is assigned an SMR code for the level of maintenance under consideration (i.e., identified as maintenance significant).

Actions – Welding, grinding, riveting, straightening, facing, machining, and/or resurfacing.

10. **Overhaul:** That maintenance effort (service/action) prescribed to restore an item to a completely serviceable/operational condition as required by maintenance standards in appropriate technical publications. Overhaul is normally the highest degree of maintenance performed by the Army. Overhaul does not normally return an item to like new condition.
11. **Rebuild:** Consists of those services/actions necessary for the restoration of unserviceable equipment to a like new condition in accordance with original manufacturing standards. Rebuild is the highest degree of materiel maintenance applied to Army equipment. The rebuild operation includes the act of returning to zero those age measurements (e.g., hours/miles) considered in classifying Army equipment/components.

Explanation of Columns in the MAC

Column (1) – Group Number. Column (1) lists Functional Group Code (FGC) numbers, the purpose of which is to identify maintenance significant components, assemblies, subassemblies, and modules with the Next Higher Assembly (NHA).

Column (2) – Component/Assembly. Column (2) contains the item names of components, assemblies, subassemblies, and modules for which maintenance is authorized.

Column (3) – Maintenance Function. Column (3) lists the functions to be performed on the item listed in column (2). (For a detailed explanation of these functions refer to “Maintenance Functions” outlined above).

Column (4) – Maintenance Level. Column (4) specifies each level of maintenance authorized to perform each function listed in column (3), by indicating work time required (expressed as man-hours in whole hours or decimals) in the appropriate sub column. This work time figure represents the active time required to perform that maintenance function at the indicated level of maintenance. If the number or complexity of the tasks within the listed maintenance function varies at different maintenance levels, appropriate work time figures are to be shown for each level. The work time figure represents the average time required to restore an item (assembly, subassembly, component, module, end item, or system) to a serviceable condition under typical field operating conditions. This time includes preparation time (including any necessary disassembly/assembly time), troubleshooting/fault location time, and quality assurance time in addition to the time required to perform the specific tasks identified for the maintenance functions authorized in the MAC. The symbol designations for the various maintenance levels are as follows:

- C – Operator or crew maintenance
- O – Unit maintenance
- F – Direct Support maintenance
- L – Specialized repair activity (SRA)
- H – General support maintenance
- D – Depot maintenance

NOTE

The "L" maintenance level is not included in column (4) of the MAC. Functions to this level of maintenance are identified by a work time figure in the "H" column of column (4), and an associated reference code is used in the REMARKS column (6). This code is keyed to the remarks and the SRA complete repair application is explained there.

Column (5) – Tools and Equipment Reference Code. Column (5) specifies, by code, those common tool sets (not individual tools), common Test, Measurement and Diagnostic Equipment (TMDE), and special tools, special TMDE and special support equipment required to perform the designated function. Codes are keyed to the entries in the tools and test equipment table (WP 0062 00, Table 2).

Column (6) – Remarks Code. When applicable, this column contains a letter code, in alphabetical order, which is keyed to the remarks table entries (WP 0062 00, Table 3).

Explanation of Columns in the Tools and Test Equipment Requirements (WP 0047 00, Table 2)

Column (1) – Tool or Test Equipment Reference Code. The tool or test equipment reference code correlates with a code used in column (5) of the MAC.

Column (2) – Maintenance Level. The lowest level of maintenance authorized to use the tool or test equipment.

Column (3) – Nomenclature. Name or identification of the tool or test equipment.

Column (4) – National Stock Number (NSN). The NSN of the tool or test equipment.

Column (5) – Tool Number. The manufacturer's part number, model number, or type number.

Explanation of Columns in the Remarks (WP 0062 00, Table 3)

Column (1) – Remarks Code. The code recorded in column (6) of the MAC.

Column (2) – Remarks. This column lists information pertinent to the maintenance function being performed as indicated in the MAC.

END OF WORK PACKAGE

**OPERATOR, UNIT AND DIRECT SUPPORT MAINTENANCE
 AUTHORIZED STOCKAGE LIST MOBILITY SYSTEM (ASLMS)**

**MODEL NUMBER FPU-8/12 PARTS (OD) P/N 15005002-001
 NSN 5411-01-523-2071
 MODEL NUMBER FPU-8/12 PARTS (DS) P/N 15005002-002
 NSN 5411-01-523-2072
 MODEL NUMBER FPU-8/12 BULK (OD) P/N 15005001-001
 NSN 5411-01-523-2073
 MODEL NUMBER FPU-8/12 BULK (DS) P/N 15005001-002
 NSN 5411-01-523-2074**

MAINTENANCE ALLOCATION CHART (MAC)

Table 1. MAC for Authorized Stockage List Mobility System (ASLMS)

(1) Group Number	(2) Component/Assembly	(3) Maintenance Function	(4) Maintenance Level					(5) Tools and Equipment Ref Code	(6) Remarks
			Unit		Direct Support	General Support	Depot		
			C	O	F	H	D		
00	ASLMS FPU 8/12								
01	FPU-12 Parts and Bulk Container								
0101	Door Assemblies	Inspect Service Align Replace Repair	0.1	0.1 0.2	0.1 0.2 0.5 2.0 1.0			4, 5	
0102	Vertical Rack Frame	Inspect Service Repair Replace	0.2	0.2 0.2	0.5 1.0			4, 5, 9	

Table 1. MAC for Authorized Stockage Mobility System (ASLMS) - continued

(1) Group Number	(2) Component/Assembly	(3) Maintenance Function	(4) Maintenance Level					(5) Tools and Equipment Ref Code	(6) Remarks
			Unit		Direct Support	General Support	Depot		
			C	O	F	H	D		
0103	EPC Pole Storage	Inspect Service Replace Repair		0.2 0.5 0.5 0.5				4	
010301	Mount Cap	Inspect Service Replace		0.2 0.5 0.5				4	
01030101	Pin with Lanyard	Inspect Replace Repair		0.2 0.5 0.5				4	
0104	Parts Storage								
010401	Constraint Bar	Inspect Replace Repair	0.1	0.1 0.1 0.2				2, 3, 5, 8	
01040101	Pin with Lanyard	Inspect Replace		0.1 0.2				2, 3, 5, 8	
010402	Drawer Assemblies	Inspect Service Replace		0.2 0.2 0.7				4	
010403	Drawer Slides	Inspect Service Replace		0.1 0.1 0.2				4	
0105	Bulk Storage								
010501	Pallet/Cargo Nets	Inspect Service Replace Repair	0.2	0.2 0.2 0.1 0.5	0.5			2, 4, 8	

Table 1. MAC for Authorized Stockage Mobility System (ASLMS) - continued

(1) Group Number	(2) Component/Assembly	(3) Maintenance Function	(4) Maintenance Level					5) Tools and Equipment Ref Code	(6) Remarks
			Unit		Direct Support	General Support	Depot		
			C	O	F	H	D		
010502	Pallet Ledge	Inspect Service Replace Repair	0.2	0.2 0.1 0.5 1.0				4	
01050201	Rear Cam Lock Assembly	Inspect Service Replace Repair		0.1 0.1 0.5 1.0				4	
02	FPU-8 Container Parts and Bulk								
0201	Door Assemblies	Inspect Service Align Replace Repair	0.1	0.1 0.2	0.1 0.2 0.5 2.0 1.0			4, 5, 7	
0202	Rear Roller Assembly	Inspect Service Replace Repair		0.1 0.1 0.2 0.3				4	
020201	Pin with Lanyard	Inspect Replace Repair		0.1 0.1 0.2					
0203	Parts Storage								
020301	Floor Adapter Plate	Inspect Service Replace Repair		0.2 0.1 0.6 0.6				4	

Table 1. MAC for Authorized Stockage Mobility System (ASLMS) - continued

(1) Group Number	(2) Component/Assembly	(3) Maintenance Function	(4) Maintenance Level					(5) Tools and Equipment Ref Code	(6) Remarks
			Unit		Direct Support	General Support	Depot		
			C	O	F	H	D		
020302	ASLMS Module	Inspect	0.1	0.1				2, 3, 4, 8	
		Service		0.2					
		Replace		0.2					
		Repair		0.5					
02030201	Module Basket	Inspect		0.2				4	
		Service		0.2					
		Replace		0.5					
		Repair		0.5					
0203020101	Shelf Assembly	Inspect		0.2				4	
		Service		0.2					
		Replace		0.5					
		Repair		0.5					
02030202	Module Cabinet	Inspect		0.2				4	
		Service		0.2					
		Replace		0.5					
		Repair		0.5					
0203020201	3G Bar	Inspect		0.1				2, 3, 4, 8	
		Service		0.2					
		Replace		0.2					
020302020101	Pin with Lanyard	Inspect		0.1				4	
		Replace		0.2					
		Repair		0.2					
0203020202	Drawer Assemblies	Inspect		0.1				4	
		Service		0.2					
		Replace		0.5					
		Repair		0.5					
0204	Bulk Storage								

Table 1. MAC for Authorized Stockage Mobility System (ASLMS) - continued

(1) Group Number	(2) Component/Assembly	(3) Maintenance Function	(4) Maintenance Level					(5) Tools and Equipment Ref Code	(6) Remarks
			Unit		Direct Support	General Support	Depot		
			C	O	F	H	D		
020401	Vertical Rack Frame	Inspect	0.2	0.2				4, 5, 9	
		Service		0.2					
		Replace			0.5				
		Repair			1.0				
020402	Pallet/Cargo Nets	Inspect	0.2	0.2				4,2	
		Service		0.2					
		Replace		0.1					
		Repair		0.5	0.5				
020403	Pallet Ledge	Inspect	0.2	0.2				4	
		Service		0.1					
		Replace		0.5					
		Repair		1.0					
02040301	Rear Cam Lock Assembly	Inspect		0.1				4	
		Service		0.1					
		Replace		0.5					
		Repair		1.0					
03	Folding Steps	Inspect	0.1	0.1				4, 5	
		Service		0.1					
		Replace		0.2					
04	Connector Kit	Inspect		0.2				4, 5	
		Service		0.5					
		Replace		0.5					
0401	Load Rail Connector Assembly	Inspect		0.2				4, 5	
		Service		0.5					
		Replace		0.5					
040101	Transversal Stabilizer	Inspect		0.2				4, 5	
		Service		0.5					
		Replace		0.5					

Table 1. MAC for Authorized Stockage Mobility System (ASLMS) - continued

(1) Group Number	(2) Component/Assembly	(3) Maintenance Function	(4) Maintenance Level					(5) Tools and Equipment Ref Code	(6) Remarks
			Unit		Direct Support	General Support	Depot		
			C	O	F	H	D		
04010101	Tensioning Block	Inspect		0.2				4, 5	
		Service		0.5					
		Replace		0.5					
05	Fork Pocket Plug Assembly	Inspect		0.2			4		
		Service		0.2					
		Replace		0.5					
		Repair		1.0					
06	Electrical System								
0601	Distribution Boxes	Inspect		0.5			4, 1		
		Replace			0.1				
0602	Transformer	Inspect		0.5			4		
		Test			0.5				
		Replace			0.5				
0603	A/C								
060301	Cable A/C, 150'	Inspect		0.2			1, 4, 5		
		Repair		1.0					
		Replace			1.0				
060302	Cable A/C, 9'	Inspect		0.2			1, 4, 5		
		Repair		0.1					
		Replace			1.0				
060303	Receptacle GFCI	Inspect		0.1			1, 4, 5		
		Replace		0.2					
		Test		0.1					
0604	D/C	Inspect		0.5					
		Repair			1.0				
060401	Cable D/C, 9'	Inspect		0.5			1, 4, 5		
		Repair		0.2					
		Replace			1.0				

Table 1. MAC for Authorized Stockage Mobility System (ASLMS) - continued

(1) Group Number	(2) Component/Assembly	(3) Maintenance Function	(4) Maintenance Level					(5) Tools and Equipment Ref Code	(6) Remarks
			Unit		Direct Support	General Support	Depot		
			C	O	F	H	D		
060402	12-Volt Light Assembly	Inspect		0.5				4, 5	
		Test			0.5				
		Repair			1.5				
060403	Light Pole Assembly	Inspect		0.2				4, 5	
		Replace		0.2					
		Repair		0.2					
07	Vent System	Inspect		0.2				4, 5	
		Replace		0.5					
		Repair		1.0					
0701	Vent Filter	Inspect		0.2					
		Replace		0.5					
08	EPC Assembly	Inspect		0.5				5	
		Service		0.5					
		Replace		1.0					
		Repair			1.0				
0801	Canvas, EPC	Inspect		0.5				5	
		Service		0.5					
		Replace		1.0					
		Repair			1.0				
0802	Securing Kit, EPC	Inspect		0.2				4	
		Service		0.5					
		Replace		0.5					
		Repair		0.5					
09	Poles, EPC	Inspect		0.5				4	
		Service		0.5					
		Replace		0.2					
0901	Pin W /Lanyard	Inspect		0.1				4	
		Replace		0.1					
		Repair		0.2					

Table 2. Tools and Test Equipment for Authorized Stockage List Mobility System (ASLMS)

TOOL OR TEST EQUIPMENT REF CODE	MAINTENANCE LEVEL	NOMENCLATURE	NATIONAL STOCK NUMBER	TOOL NUMBER
1	O, F	Crimping & Stripping Tool	5110-01-430-6009	
2	O, F	Drill	5133-00-227-9667	
3	O, F	Drill Bit, 3/16-IN.	5133-01-437-3756	
4	O, F	General Mechanic's Tool Kit	5180-00-177-7033	
5	O, F	Insertion/Extraction Tool	5120-01-068-6511	
6	C, O, F	Ladder	5440-01-415-1241	
7	C, O, F	Pinch Bar	5120-00-240-6040	
8	O, F	Riveting Tool	5120-00177-9839	
9	O, F	Rivnut Tool		RNHT-3118

Table 3. Remarks for Authorized Stockage List Mobility System (ASLMS)

REMARKS CODE	REMARKS

END OF WORK PACKAGE

OPERATOR, UNIT AND DIRECT SUPPORT MAINTENANCE**AUTHORIZED STOCKAGE LIST MOBILITY SYSTEM (ASLMS)****MODEL NUMBER FPU-8/12 PARTS (OD) P/N 15005002-001
NSN 5411-01-523-2071****MODEL NUMBER FPU-8/12 PARTS (DS) P/N 15005002-002
NSN 5411-01-523-2072****MODEL NUMBER FPU-8/12 BULK (OD) P/N 15005001-001
NSN 5411-01-523-2073****MODEL NUMBER FPU-8/12 BULK (DS) P/N 15005001-002
NSN 5411-01-523-2074**

REPAIR PARTS AND SPECIAL TOOLS LIST (RPSTL) INTRODUCTION

INTRODUCTION**SCOPE**

This RPSTL lists and authorizes spares and repair parts; special tools; special test, measurement, and diagnostic equipment (TMDE); and other special support equipment required for performance of Operator, Unit, and Direct Support maintenance of the Authorized Stockage List Mobility System (ASLMS). It authorizes the requisitioning, issue, and disposition of spares, repair parts, and special tools as indicated by the Source, Maintenance, and Recoverability (SMR) codes.

GENERAL

In addition to the Introduction work package, this RPSTL is divided into the following work packages:

1. Repair Parts List Work packages. Work packages containing lists of spares and repair parts authorized by this RPSTL for use in the performance of maintenance. These work packages also include parts which must be removed for replacement of the authorized parts. Parts lists are composed of functional groups in ascending alphanumeric sequence, with the parts in each group listed in ascending figure and item number sequence. Sending units, brackets, filters, and bolts are listed with the component they mount on. Bulk materials are listed by item name in FIG. BULK at the end of the work Packages. Repair parts kits are listed separately in their own functional group and work Package. Repair parts for reparable special tools are also listed in a separate work Package. Items listed are shown on the associated illustrations.
2. Special Tools List Work Packages. Work Packages containing lists of special tools, special TMDE, and special support equipment authorized by this RPSTL (as indicated by Basis of Issue (BOI) information in the Description and Usable On Code (UOC) column). Tools that are components of common tool sets and/or Class VII are not listed.
3. Cross-Reference Indexes Work Packages. There are two cross-reference indexes work packages in this RPSTL: the National Stock Number (NSN) Index work Package and the Part Number (P/N) Index work Package. The National Stock Number Index work Package refers you to the figure and item number. The Part Number Index work Package refers you to the figure and item number.

EXPLANATION OF COLUMNS IN THE REPAIR PARTS LIST AND SPECIAL TOOLS LIST WORK PACKAGES

ITEM NO. (Column (1)). Indicates the number used to identify items called out in the illustration.

SMR CODE (Column (2)). The SMR code containing supply/requisitioning information, maintenance level authorization criteria, and disposition instructions, as shown in the following breakout:

<u>Source Code</u>		<u>Maintenance Code</u>		<u>Recoverability Code</u>
XX		XX		X
1st two positions: How to get an item.	3rd position: Who can install, replace, or use the item	4th position: Who can do complete repair* on the item	5th position: Who determines disposition action on unserviceable items.	

*Complete Repair: Maintenance capacity, capability, and authority to perform all corrective maintenance tasks of the "Repair" function in a use/user environment in order to restore serviceability to a failed item

Source Code. The source code tells you how you get an item needed for maintenance, repair, or overhaul of an end item/equipment. Explanations of source codes follow:

<u>Source Code</u>	<u>Application/Explanation</u>
PA PB PC PD PE PF PG	Stock items; use the applicable NSN to requisition/request items with these source codes. They are authorized to the level indicated by the code entered in the 3 rd position of the SMR code.

NOTE

Items coded PC are subject to deterioration.

KD KF KB	Items with these codes are not to be requested/requisitioned individually. They are part of a kit which is authorized to the maintenance level indicated in the 3rd position of the SMR code. The complete kit must be requisitioned and applied.
MO – Made at unit/AVUM level MF – Made at DS/AVIM level MH – Made at GS level ML – Made at SRA MD – Made at depot	Items with these codes are not to be requested/requisitioned individually. They must be made from bulk materiel which is identified by the P/N in the DESCRIPTION AND USABLE ON CODE (UOC) column and listed in the bulk materiel group work Package of the RPSTL. If the item is authorized to you by the 3rd position code of the SMR code, but the source code indicates it is made at higher level, order the item from the higher level of maintenance.

<u>Source Code</u>	<u>Application/Explanation</u>
AO – Assembled by unit/AVUM level AF – Assembled by DS/AVIM level AH – Assembled by GS level AL – Assembled by SFA AD – Assembled by depot	Items with these codes are not to be requested/requisitioned individually. The parts that make up the assembled item must be requisitioned or fabricated and assembled at the level of maintenance indicated by the source code. If the 3rd position of the SMR code authorizes you to replace the item, but the source code indicates the item is assembled at a higher level, order the item from the higher level of maintenance.
XA	Do not requisition an “XA” coded item. Order the next higher assembly. (Refer to NOTE below).
XB	If an item is not available from salvage, order it using the CAGE and P/N.
XC	Installation drawings, diagrams, instruction sheets, field service drawings; identified by manufacturer’s P/N.
XD	Item is not stocked. Order an XD-coded item through normal supply channels using the CAGE and P/N given, if no NSN is available.

NOTE

Cannibalization or controlled exchange, when authorized, may be used as a source of supply for items with the above source codes except for those items source coded “XA” or those aircraft support items restricted by requirements of AR 750-1.

Maintenance Code. Maintenance codes tell you the level(s) of maintenance authorized to use and repair support items. The maintenance codes are entered in the third and fourth positions of the SMR code as follows:

Third Position. The maintenance code entered in the third position tells you the lowest maintenance level authorized to remove, replace, and use an item. The maintenance code entered in the third position will indicate authorization to the following levels of maintenance:

<u>Maintenance Code</u>	<u>Application/Explanation</u>
C	Crew or operator maintenance done within unit/AVUM maintenance.
O	Unit level/AVUM maintenance can remove, replace, and use the item.
F	Direct support/AVIM maintenance can remove, replace, and use the item.
H	General support maintenance can remove, replace, and use the item.
L	Specialized repair activity can remove, replace, and use the item.
D	Depot can remove, replace, and use the item.

Fourth Position. The maintenance code entered in the fourth position tells you whether or not the item is to be repaired and identifies the lowest maintenance level with the capability to do complete repair (perform all authorized repair functions).

NOTE

Some limited repair may be done on the item at a lower level of maintenance, if authorized by the Maintenance Allocation Chart (MAC) and SMR codes.

<u>Maintenance Code</u>	<u>Application/Explanation</u>
O	Unit/AVUM is the lowest level that can do complete repair of the item.
F	Direct support/AVIM is the lowest level that can do complete repair of the item.
H	General support is the lowest level that can do complete repair of the item.
L	Specialized Repair Activity (SRA) is the lowest level that can do complete repair of the item.
D	Depot is the lowest level that can do complete repair of the item.
Z	Non-repairable. No repair is authorized.
B	No repair is authorized. No parts or special tools are authorized for maintenance of "B" coded items. However, the items may be reconditioned by adjusting, lubricating, etc., at the user level.

Recoverability Code. Recoverability codes are assigned to items to indicate the disposition action on unserviceable items. The recoverability code is shown in the fifth position of the SMR code as follows:

<u>Recoverability Code</u>	<u>Application/Explanation</u>
Z	Non-repairable item. When unserviceable, condemn and dispose of the item at the level of maintenance shown in the third position of the SMR code.
O	Repairable item. When uneconomically repairable, condemn and dispose of the item at the unit level.
F	Repairable item. When uneconomically repairable, condemn and dispose of the item at the direct support level.
H	Repairable item. When uneconomically repairable, condemn and dispose of the item at the general support level.
D	Repairable item. When beyond lower level repair capability, return to depot. Condemnation and disposal of item are not authorized below depot level.
L	Repairable item. Condemnation and disposal not authorized below Specialized Repair Activity (SRA).
A	Items requires special handling or condemnation procedures because of specific reasons (such as precious metal content, high dollar value, critical materiel, or hazardous materiel). Refer to appropriate manuals/directives for specific instructions.

NSN (Column (3)). The NSN for the item is listed in this column.

CAGEC (Column (4)). The Commercial and Government Entity Code (CAGEC) is a five-digit code which is used to identify the manufacturer, distributor, or Government agency/activity that supplies the item.

PART NUMBER (Column (5)). Indicates the primary number used by the manufacturer (individual, company, firm, corporation, or Government activity), which controls the design and characteristics of the item by means of its engineering drawings, specifications, standards, and inspection requirements to identify an item or range of items.

NOTE

When you use an NSN to requisition an item, the item you receive may have a different P/N from the number listed.

DESCRIPTION AND USABLE ON CODE (UOC) (Column (6)). This column includes the following information:

1. The federal item name, and when required, a minimum description to identify the item.
2. P/Ns of bulk materials are referenced in this column in the line entry to be manufactured or fabricated.
3. Hardness Critical Item (HCI). A support item that provides the equipment with special protection from electromagnetic pulse (EMP) damage during a nuclear attack.
4. The statement END OF FIGURE appears just below the last item description in column (6) for a given figure in both the repair parts list and special tools list work Packages.

QTY (Column (7)). The QTY (quantity per figure) column indicates the quantity of the item used in the breakout shown on the illustration/figure, which is prepared for a functional group, sub-functional group, or an assembly. A "V" appearing in this column instead of a quantity indicates that the quantity is variable and quantity may change from application to application.

EXPLANATION OF CROSS-REFERENCE INDEXES WORK PACKAGES FORMAT AND COLUMNS.

1. National Stock Number (NSN) Index Work Package.

STOCK NUMBER Column. This column lists the NSN in National Item Identification Number (NIIN) sequence. The NIIN consists of the last nine digits of the NSN.

NSN
(e.g.,5385-01-574-1476)

When using this column to locate an item, ignore the first four digits of the NSN. However, the complete NSN should be used when ordering items by stock number.

FIG. Column. This column lists the number of the figure where the item is identified/located. The figures are in numerical order in the repair parts list and special tools list work Packages.

ITEM Column. The item number identifies the item associated with the figure listed in the adjacent FIG. Column. This item is also identified by the NSN listed on the same line.

2. Part Number (P/N) Index Work Package. P/Ns in this index are listed in ascending alphanumeric sequence (vertical arrangement of letter and number combinations which places the first letter or digit of each group in order A through Z, followed by the numbers 0 through 9 and each following letter or digit in like order).

PART NUMBER Column. Indicates the P/N assigned to the item.

FIG. Column. This column lists the number of the figure where the item is identified/located in the repair parts list and special tools list work Packages.

ITEM Column. The item number is the number assigned to the item as it appears in the figure referenced in the adjacent figure number column.

SPECIAL INFORMATION

UOC. The UOC appears in the lower left corner of the Description Column heading. Usable On Codes are shown as “UOC: . . .” in the Description Column (justified left) on the first line under the applicable item/nomenclature. None coded items are applicable to all models. Identification of the UOCs used in this RPSTL are:

<u>Code</u>	<u>Used On</u>
FTR	Model FPU-8/12-PARTS OD – Olive Drab
FTS	Model FPU-8/12-BULK OD – Olive Drab
FTT	Model FPU-8/12-PARTS DS – Desert Sand
FTU	Model FPU-8/12-BULK DS – Desert Sand

Fabrication Instructions. Bulk materiel required to manufacture items are listed in the bulk materiel functional group of this RPSTL. Part numbers for bulk materiel are also referenced in the Description Column of the line item entry for the item to be manufactured/fabricated. Detailed fabrication instructions for items source coded to be manufactured or fabricated are found in: Not Applicable.

Index Numbers. Items which have the word BULK in the figure column will have an index number shown in the item number column. This index number is a cross-reference between the NSN and P/N index work Packages and the bulk materiel list in the repair parts list work Package.

Associated Publications. The publication(s) listed below pertain to the Authorized Stockage List Mobility System (ASLMS):

<u>Publication</u>	<u>Short Title</u>
TM 9-6115-642-10	Operator’s Manual, Generator Set, Skid Mounted, Tactical Quiet, 10 KW, 60 and 400 Hz
TM 9-6115-642-24	Unit, Direct Support and General Support Maintenance Manual for Generator Set, Skid Mounted, Tactical Quiet

Illustrations List. The illustrations in this RPSTL contain unit and direct support authorized items. The tabular list in the repair parts list work Package contains only those parts coded “O” and “F” in the third position of the SMR code, therefore, there may be a break in the item number sequence.

HOW TO LOCATE REPAIR PARTS

1. When NSNs or P/Ns Are Not Known.

First. Using the table of contents, determine the assembly group to which the item belongs. This is necessary since figures are prepared for assembly groups and subassembly groups, and lists are divided into the same groups.

Second. Find the figure covering the functional group or the sub functional group to which the item belongs.

Third. Identify the item on the figure and note the number(s).

Fourth. Look in the repair parts list work Packages for the figure and item numbers. The NSNs and part numbers are on the same line as the associated item numbers.

2. When NSN Is Known.

First. If you have the NSN, look in the STOCK NUMBER column of the NSN index work Package. The NSN is arranged in NIIN sequence. Note the figure and item number next to the NSN.

Second. Turn to the figure and locate the item number. Verify that the item is the one you are looking for.

3. When the P/N Is Known.

First. If you have the P/N and not the NSN, look in the PART NUMBER column of the P/N index work Package. Identify the figure and item number.

Second. Look up the item on the figure in the applicable repair parts list work package.

END OF WORK PACKAGE

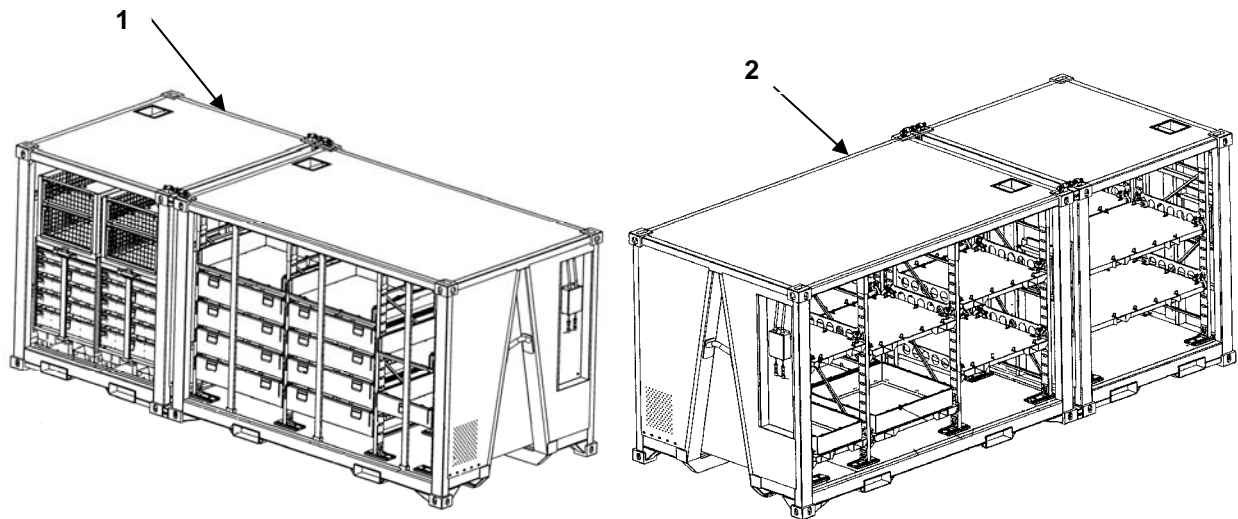
OPERATOR'S, UNIT AND DIRECT SUPPORT MAINTENANCE**AUTHORIZED STOCKAGE LIST MOBILITY SYSTEM (ASLMS)****MODEL NUMBER FPU-8/12 PARTS (OD) P/N 15005002-001****NSN 5411-01-523-2071****MODEL NUMBER FPU-8/12 PARTS (DS) P/N 15005002-002****NSN 5411-01-523-2072****MODEL NUMBER FPU-8/12 BULK (OD) P/N 15005001-001****NSN 5411-01-523-2073****MODEL NUMBER FPU-8/12 BULK (DS) P/N 15005001-002****NSN 5411-01-523-2074****ASLMS FPU 8/12****NOTE: DOORS REMOVED FOR CLARITY****Figure 1. ASLMS FPU 8/12**

(1) ITEM NO.	(2) SMR CODE	(3) NSN	(4) CAGEC	(5) PART NUMBER	(6) DESCRIPTION AND USABLE ON CODE (UOC)	(7) QTY
					GROUP 00 ASLMS FPU 8/12 FIG. 1 ASLMS FPU 8/12	
1	PAFDD	5411-01-523-2071	1NSG3	15005002-001	FPU 8/12, PARTS, OD UOC: FTR	1
	PAFDD	5411-01-523-2072	1NSG3	15005002-002	FPU 8/12, PARTS, DS UOC: FTT	1
2	PAFDD	5411-01-523-2073	1NSG3	15005001-001	FPU 8/12, BULK, OD UOC: FTS	1
	PAFDD	5411-01-523-2074	1NSG3	15005001-002	FPU 8/12, BULK, DS UOC: FTU	1
					END OF FIGURE	

**OPERATOR'S, UNIT AND DIRECT SUPPORT MAINTENANCE
AUTHORIZED STOCKAGE LIST MOBILITY SYSTEM (ASLMS)**

- MODEL NUMBER FPU-8/12 PARTS (OD) P/N 15005002-001
NSN 5411-01-523-2071**
- MODEL NUMBER FPU-8/12 PARTS (DS) P/N 15005002-002
NSN 5411-01-523-2072**
- MODEL NUMBER FPU-8/12 BULK (OD) P/N 15005001-001
NSN 5411-01-523-2073**
- MODEL NUMBER FPU-8/12 BULK (DS) P/N 15005001-002
NSN 5411-01-523-2074**

FPU-12 PARTS AND BULK CONTAINER

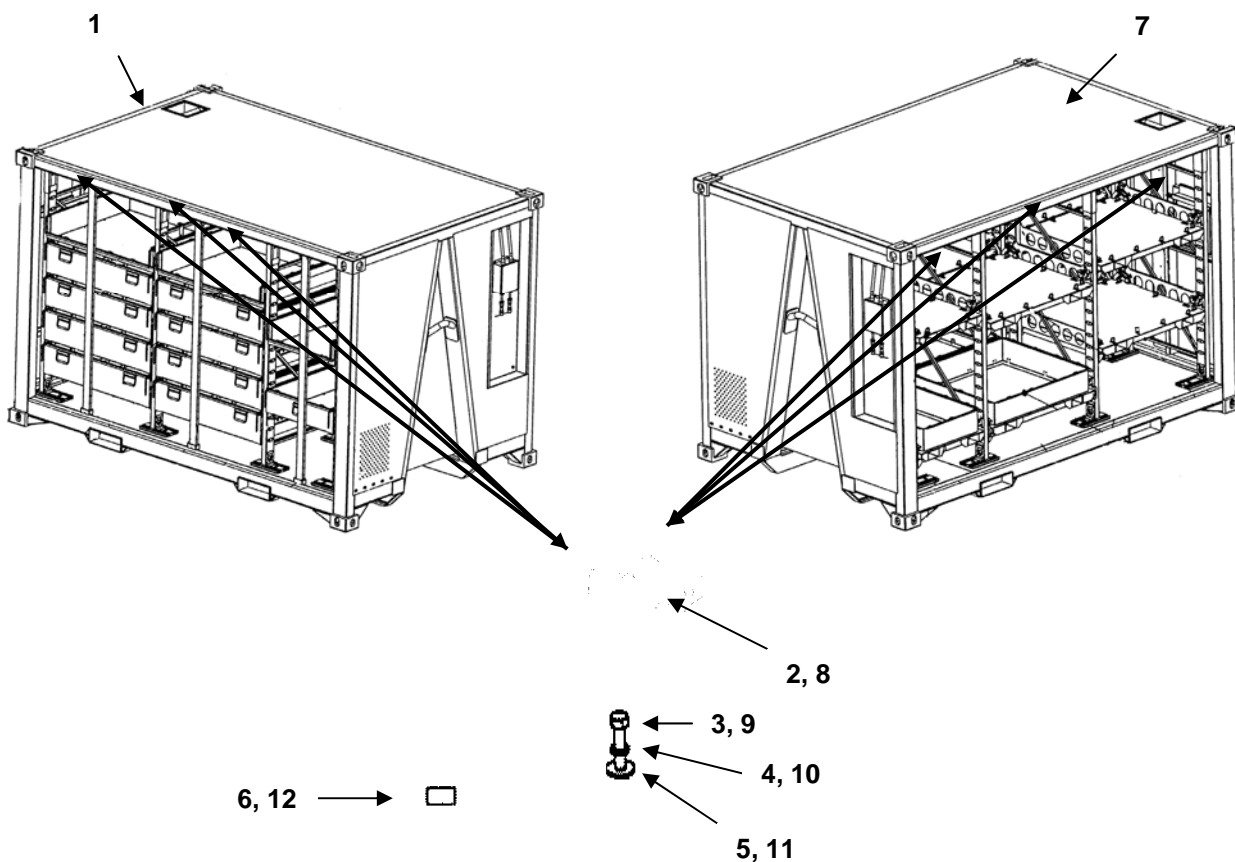

NOTE: DOORS REMOVED FOR CLARITY

Figure 2. FPU-12 Parts and Bulk Container

(1) ITEM NO.	(2) SMR CODE	(3) NSN	(4) CAGEC	(5) PART NUMBER	(6) DESCRIPTION AND USABLE ON CODE (UOC)	(7) QTY
					GROUP 01 FPU-12 PARTS AND BULK CONTAINER FIG. 2 FPU-12 PARTS AND BULK CONTAINER	
1	PAFFF	5411-01-530-1010	1NSG3	15005016-001	FPU-12-PARTS OD UOC: FTR	1
	PAFFF	5411-01-530-1016	1NSG3	15005016-002	FPU-12-PARTS DS UOC: FTT	1
2	PAOZZ	5411-01-529-8333	1NSG3	16501861-001	.BRACKET, EPC OD UOC: FTR, FTS	6
	PAOZZ	5411-01-529-8334	1NSG3	16501861-002	.BRACKET, EPC DS UOC: FTT, FTU	6
3	XDOZZ		1RDQ0	2M014	..BOLT, HEXHD ½ -13X 1	2
4	XDOZZ		1RDQ0	2V106	..WASHER, LOCK ½ GR8	2
5	XDOZZ		1RDQ0	4P533	..WASHER, FLAT ½"	2
6	XDOZZ		07BY4	3259T19	..UNI STRUT NUT	2
7	PAFFF	5411-01-530-1003	1NSG3	15005013-001	FPU-12-BULK OD UOC: FTS	1
	PAFFF	5411-01-530-1006	1NSG3	15005013-002	FPU-12-BULK DS UOC: FTU	1
8	PAOZZ	5411-01-529-8333	1NSG3	16501861-001	.BRACKET, EPC OD UOC: FTR, FTS	6
	PAOZZ	5411-01-529-8334	1NSG3	16501861-002	.BRACKET, EPC DS UOC: FTT, FTU	6
9	XDOZZ		1RDQ0	2M014	..BOLT, HEXHD ½ -13X 1	2
10	XDOZZ		1RDQ0	2V106	..WASHER, LOCK ½ GR8	2
11	XDOZZ		1RDQ0	4P533	..WASHER, FLAT ½"	2
12	XDOZZ		07BY4	3259T19	..UNI STRUT NUT	2
END OF FIGURE						

OPERATOR'S, UNIT AND DIRECT SUPPORT MAINTENANCE

AUTHORIZED STOCKAGE LIST MOBILITY SYSTEM (ASLMS)

MODEL NUMBER FPU-8/12 PARTS (OD) P/N 15005002-001

NSN 5411-01-523-2071

MODEL NUMBER FPU-8/12 PARTS (DS) P/N 15005002-002

NSN 5411-01-523-2072

MODEL NUMBER FPU-8/12 BULK (OD) P/N 15005001-001

NSN 5411-01-523-2073

MODEL NUMBER FPU-8/12 BULK (DS) P/N 15005001-002

NSN 5411-01-523-2074

DOOR ASSEMBLIES

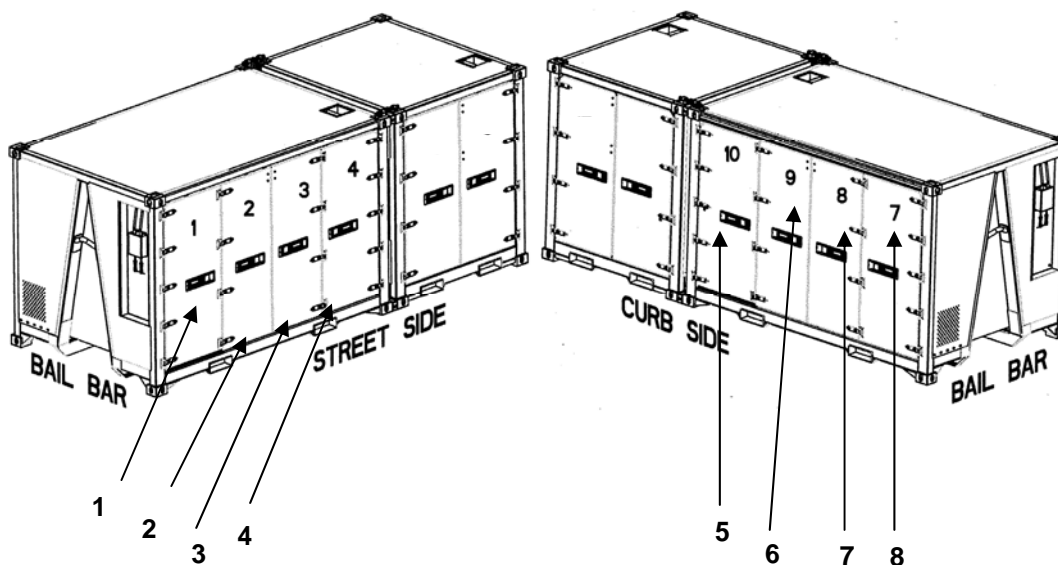

NOTE: FOR REPLACEMENT PARTS GO TO FIGURE 04

Figure 3. Door Assemblies
(Sheet 1 of 2)

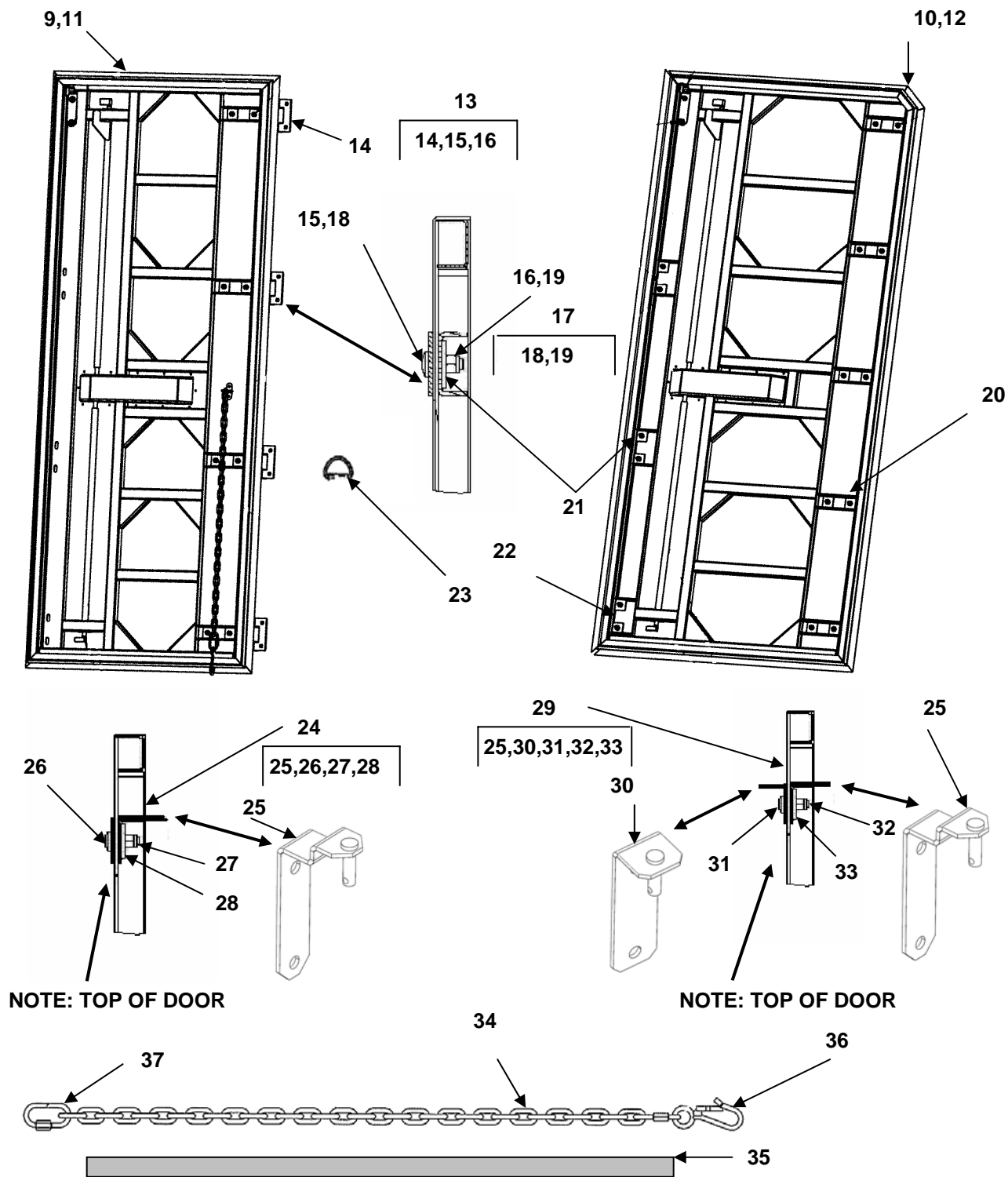

Figure 3. Door Assemblies
(Sheet 2 of 2)

(1) ITEM NO.	(2) SMR CODE	(3) NSN	(4) CAGEC	(5) PART NUMBER	(6) DESCRIPTION AND USABLE ON CODE (UOC)	(7) QTY
					GROUP 0101 DOOR ASSEMBLIES FIG. 3 DOOR ASSEMBLIES	
1	PAFFF	5411-01-529-8343	1NSG3	16505501-001	DOOR ASSY #1 OD UOC: FTR, FTS	1
	PAFFF	5411-01-529-8350	1NSG3	16505501-002	DOOR ASSY #1 DS UOC: FTT, FTU	1
2	PAFFF	5411-01-529-8332	1NSG3	16505502-001	DOOR ASSY #2 OD UOC: FTR, FTS	1
	PAFFF	5411-01-529-8334	1NSG3	16505502-002	DOOR ASSY #2 DS UOC: FTT, FTU	1
3	PAFFF	5411-01-529-8339	1NSG3	16505503-001	DOOR ASSY #3 OD UOC: FTR, FTS	1
	PAFFF	5411-01-529-8344	1NSG3	16505503-002	DOOR ASSY #3 DS UOC: FTT, FTU	1
4	PAFFF	5411-01-529-8349	1NSG3	16505504-001	DOOR ASSY #4 OD UOC: FTR, FTS	1
	PAFFF	5411-01-529-8355	1NSG3	16505504-002	DOOR ASSY #4 DS UOC: FTT, FTU	1
5	PAFFF	5411-01-529-8364	1NSG3	16505510-001	DOOR ASSY #10 OD UOC: FTR, FTS	1
	PAFFF	5411-01-529-8368	1NSG3	16505510-002	DOOR ASSY #10 DS UOC: FTT, FTU	1
6	PAFFF	5411-01-529-8356	1NSG3	16505509-001	DOOR ASSY #9 OD UOC: FTR, FTS	1
	PAFFF	5411-01-529-8361	1NSG3	16505509-002	DOOR ASSY #9 DS UOC: FTT, FTU	1
7	PAFFF	5411-01-529-8363	1NSG3	16505508-001	DOOR ASSY #8 OD UOC: FTR, FTS	1
	PAFFF	5411-01-529-8367	1NSG3	16505508-002	DOOR ASSY #8 DS UOC: FTT, FTU	1

(1)	(2)	(3)	(4)	(5)	(6)	(7)
ITEM NO.	SMR CODE	NSN	CAGEC	PART NUMBER	DESCRIPTION AND USABLE ON CODE (UOC)	QTY
8	PAFFF	5411-01-529-8352	1NSG3	16505507-001	DOOR ASSY #7 OD UOC: FTR, FTS	1
	PAFFF	01-529-8359	1NSG3	16505507-002	DOOR ASSY 37 DS UOC: FTT, FTU	
9	PAFZZ	5411-01-530-1009	1NSG3	16505513	.SEAL KIT, DOOR 1&10	1
10	PAFZZ	5411-01-530-1013	1NSG3	16505515	.SEAL KIT, DOOR 2&9	1
11	PAFZZ	5411-01-530-1017	1NSG3	16505516	.SEAL KIT, DOOR 3&8	1
12	PAFZZ	5411-01-530-1005	1NSG3	16505514	.SEAL KIT, DOOR 4&7	1
13	PAFZZ	5411-01-529-8370	1NSG3	16505545-001	.HINGE KIT, OD,DOOR2,3,8&9 UOC: FTR, FTS	4
	PAFZZ	5411-01-529-8371	1NSG3	16505545-002	.HINGE KIT, DS,DOOR2,3,8&9 UOC: FTT, FTU	1
14	XDFZZ		1NSG3	15108406-001	..HINGE OD UOC: FTR, FTS	1
	XDFZZ		1NSG3	15108406-002	..HINGE DS UOC: FTT, FTU	1
15	XDFZZ		1RDQ0	2M498	..BOLT, CARRIAGE	1
16	XDFZZ		1RDQ0	4P434	..NUT, LOCKING 3/8X16	1
17	XDFZZ		1NSG3	16505543	. MOUNTING KIT, HINGE	1
18	XDFZZ		1RDQ0	2M498	..BOLT, CARRIAGE	1
19	XDFZZ		1RDQ0	4P434	..NUT, LOCKING 3/8X16	1
20	XDFZZ		1NSG3	16502834-001	.BRACE, HINGE A OD UOC: FTR, FTS	1
	XDFZZ		1NSG3	16502834-002	.BRACE, HINGE A DS UOC: FTT, FTU	1
21	XDFZZ		1NSG3	16507022	.PLATE, HINGE	1
22	XDFZZ		1NSG3	16502835-001	.BRACE, HINGE B OD,DOOR 1,4,7&10 UOC: FTR, FTS	1
	XDFZZ		1NSG3	16502835-002	.BRACE, HINGE B DS, DOOR 1,4,7&10 UOC: FTR, FTS	1
23	XDFZZ		7B735	700 ZN	.D-RING, WELD ON, DOOR 2, 3, 8&9	1
24	PAFZZ	5411-01-529-8372	1NSG3	16505544-001	.BRACKET KIT, EPC INTERIOR,OD UOC: FTR, FTS	1
	PAFZZ	5411-01-529-8373	1NSG3	16505544-002	.BRACKET KIT, EPC INTERIOR, DS UOC: FTT, FTU	1

(1)	(2)	(3)	(4)	(5)	(6)	(7)
ITEM NO.	SMR CODE	NSN	CAGEC	PART NUMBER	DESCRIPTION AND USABLE ON CODE (UOC)	QTY
25	XDFZZ		1NSG3	16501867-001	..BRACKET, EPC A, OD UOC: FTR, FTS	2
	XDFZZ		1NSG3	16501867-002	..BRACKET, EPC A, DS UOC: FTT, FTU	1
26	XDFZZ		1RDQ0	2M498	..BOLT, CARRIAGE	1
27	XDFZZ		1RDQ0	4P531	..WASHER FLAT 3/8	1
28	XDFZZ		1RDQ0	4P434	..NUT, LOCKING 3/8X16	1
29	PAFZZ	5411-01-529-8374	1NSG3	16505546-001	.BRACKET KIT, EPC EXTERIOR,OD,DOOR 3&9 UOC: FTR, FTS	1
	PAFZZ	5411-01-529-8376	1NSG3	16505546-002	.BRACKET KIT,EPC EXTERIOR,DS,DOOR 3&9 UOC: FTT, FTU	1
30	XDFZZ		1NSG3	16501877-001	..BRACKET, EPC B, OD UOC: FTR, FTS	1
	XDFZZ		1NSG3	16501877-002	..BRACKET, EPC B, DS UOC: FTT, FTU	1
31	XDFZZ		1RDQ0	2M498	..BOLT, CARRIAGE	1
32	XDFZZ		1RDQ0	4P531	..WASHER FLAT 3/8	1
33	XDFZZ		1RDQ0	4P434	..NUT, LOCKING 3/8X16	1
34	XDOOO		1NSG3	16504253	.DOOR RESTRAINT, CHAIN ASSY, DOOR 2, 3, 8&9	1
35	XDOZZ		1NSG3	16504256	..SLEEVE	1
36	XDOZZ		75535	1023056	..HOOK, SAFETY SNAP	1
37	XDOZZ		1RDQ0	4J199	..CONNECTOR, THREADED	2
END OF FIGURE						

OPERATOR'S, UNIT AND DIRECT SUPPORT MAINTENANCE

AUTHORIZED STOCKAGE LIST MOBILITY SYSTEM (ASLMS)

MODEL NUMBER FPU-8/12 PARTS (OD) P/N 15005002-001

NSN 5411-01-523-2071

MODEL NUMBER FPU-8/12 PARTS (DS) P/N 15005002-002

NSN 5411-01-523-2072

MODEL NUMBER FPU-8/12 BULK (OD) P/N 15005001-001

NSN 5411-01-523-2073

MODEL NUMBER FPU-8/12 BULK (DS) P/N 15005001-002

NSN 5411-01-523-2074

VERTICAL RACK FRAME

NOTE: DOORS REMOVED FOR CLARITY

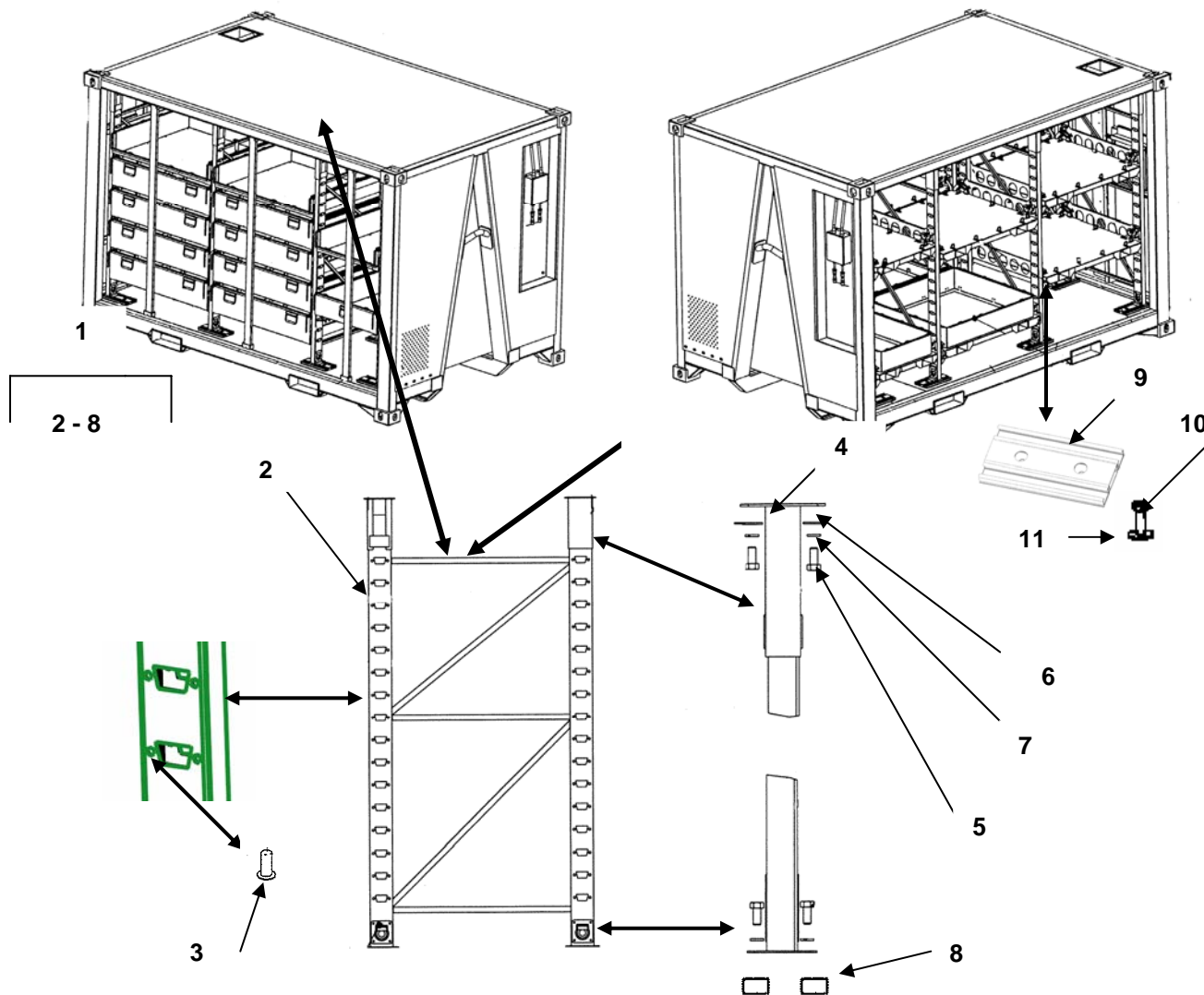

Figure 4. Vertical Rack Frame

(1) ITEM NO.	(2) SMR CODE	(3) NSN	(4) CAGEC	(5) PART NUMBER	(6) DESCRIPTION AND USABLE ON CODE (UOC)	(7) QTY
GROUP 0102 VERTICAL RACK FRAME FIG. 4 VERTICAL RACK FRAME						
1	PAFFF	5411-01-530-1015	INSG3	16500250-001	VERTICAL RACK ASSY, OD UOC: FTR, FTS	8
	PAFFF	5411-01-530-1019	INSG3	16500250-002	VERTICAL RACK ASSY, DS UOC: FTT, FTU	8
2	XDFFF		1NSG3	15700401-001	.VERTICAL RACK , OD UOC: FTR, FTS	1
	XDFFF		1NSG3	15700401-002	.VERTICAL RACK , DS UOC: FTT, FTU	1
3	XDFZZ		OVNM9	CAH2-3118-150	..NUT, RIVET 5/16" 18	
4	PAFZZ	5411-01-530-1020	1NSG3	16500252-001	.ATTACHMENT UPPER, OD UOC: FTR, FTS	2
	PAFZZ	5411-01-530-1021	1NSG3	16500252-002	.ATTACHMENT UPPER, DS UOC: FTT, FTU	2
5	XDFZZ		1RDQ0	2M014	.BOLT, HEXHD 1/2-13 X 1	12
6	XDFZZ		1RDQ0	4P533	.WASHER, FLAT, 1/2	4
7	XDFZZ		1RDQ0	2V106	.WASHER, LOCK 1/2	12
8	XDFZZ		07BY4	3259T19	.UNI STRUT NUT	12
9	PAFZZ	5411-01-529-8375	1NSG3	16500451-001	PLATE, ADAPTER OD UOC: FTR, FTS	16
	PAFZZ	5411-01-529-9249	1NSG3	16500451-002	PLATE, ADAPTER DS UOC: FTT, FTU	16
10	XDFZZ		1RDQ0	4P286	.BOLT, HEXHD 1/2 -13 X 1 1/2	2
11	XDFZZ		80064	9113874	.WASHER, LOCK 1/2 GR8	2
END OF FIGURE						

OPERATOR'S, UNIT AND DIRECT SUPPORT MAINTENANCE

AUTHORIZED STOCKAGE LIST MOBILITY SYSTEM (ASLMS)

MODEL NUMBER FPU-8/12 PARTS (OD) P/N 15005002-001
 NSN 5411-01-523-2071

MODEL NUMBER FPU-8/12 PARTS (DS) P/N 15005002-002
 NSN 5411-01-523-2072

MODEL NUMBER FPU-8/12 BULK (OD) P/N 15005001-001
 NSN 5411-01-523-2073

MODEL NUMBER FPU-8/12 BULK (DS) P/N 15005001-002
 NSN 5411-01-523-2074

EPC POLE STORAGE

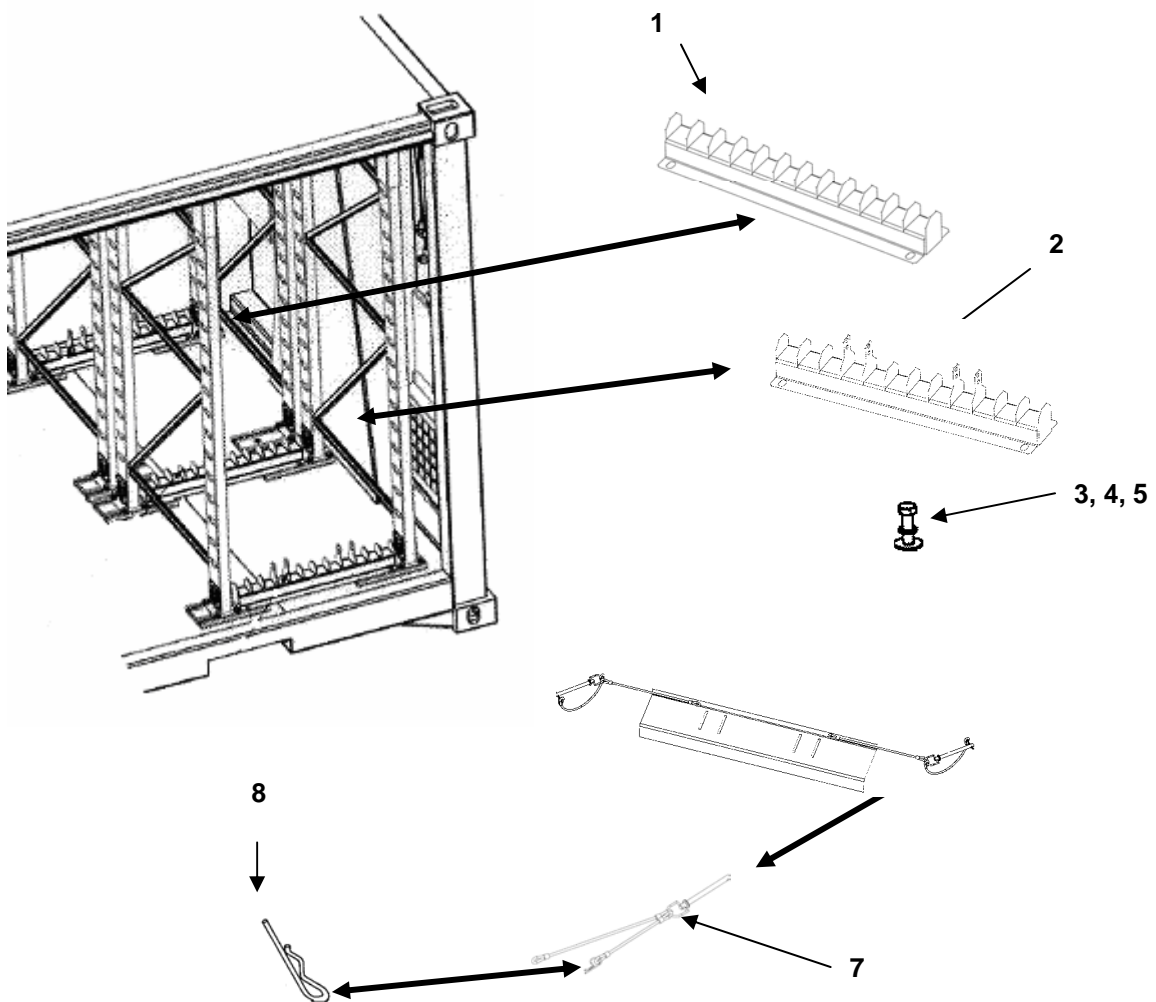

Figure 5. EPC Pole Storage

(1)	(2)	(3)	(4)	(5)	(6)	(7)
ITEM NO.	SMR CODE	NSN	CAGEC	PART NUMBER	DESCRIPTION AND USABLE ON CODE (UOC)	QTY
					GROUP 0103 EPC POLE STORAGE FIG. 5 EPC POLE STORAGE	
1	PAOZZ	5411-01-529-8377	1NSG3	16501863-001	BRACKET, MOUNTING EPC, POLE CENTER OD UOC: FTR, FTS	1
	PAOZZ	5411-01-529-8383	1NSG3	16501863-002	BRACKET, MOUNTING EPC, POLE CENTER DS UOC: FTT, FTU	1
2	PAOZZ	5411-01-529-8379	1NSG3	16501862-001	BACKET, MOUNT, FLOOR EPC POLE OD UOC: FTR, FTS	2
	PAOZZ	5411-01-529-8381	1NSG3	16501862-002	BRACKET, MOUNT FLOOR EPC POLE DS UOC: FTT, FTU	2
3	XDOZZ		1RDQ0	2M014	.BOLT, HEXHD ½ -13X 1	12
4	XDOZZ		1RDQ0	4P533	.WASHER, FLAT ½"	12
5	XDOZZ		1RDQ0	2V106	.WASHER, LOCK ½ GR8	12
6	PAOOO	5411-01-529-8375	1NSG3	16501866-001	CAP, MOUNTING POLE EPC OD UOC: FTR, FTS	2
	PAOOO	5411-01-529-8380	1NSG3	16501866-002	CAP, MOUNTING POLE EPC DS UOC: FTT, FTU	2
7	PAOOO	5411-01-530-1030	1NSG3	15120662	.PIN W/ LANYARD	2
8	XDOZZ		07BY4	98335A065	..PIN, HAIRPIN COTTER	1
					END OF FIGURE	

OPERATOR'S, UNIT AND DIRECT SUPPORT MAINTENANCE

AUTHORIZED STOCKAGE LIST MOBILITY SYSTEM (ASLMS)

**MODEL NUMBER FPU-8/12 PARTS (OD) P/N 15005002-001
NSN 5411-01-523-2071**

**MODEL NUMBER FPU-8/12 PARTS (DS) P/N 15005002-002
NSN 5411-01-523-2072**

**MODEL NUMBER FPU-8/12 BULK (OD) P/N 15005001-001
NSN 5411-01-523-2073**

**MODEL NUMBER FPU-8/12 BULK (DS) P/N 15005001-002
NSN 5411-01-523-2074**

CONSTRAINT BAR

**NOTE: DOORS REMOVED FOR
CLARITY**

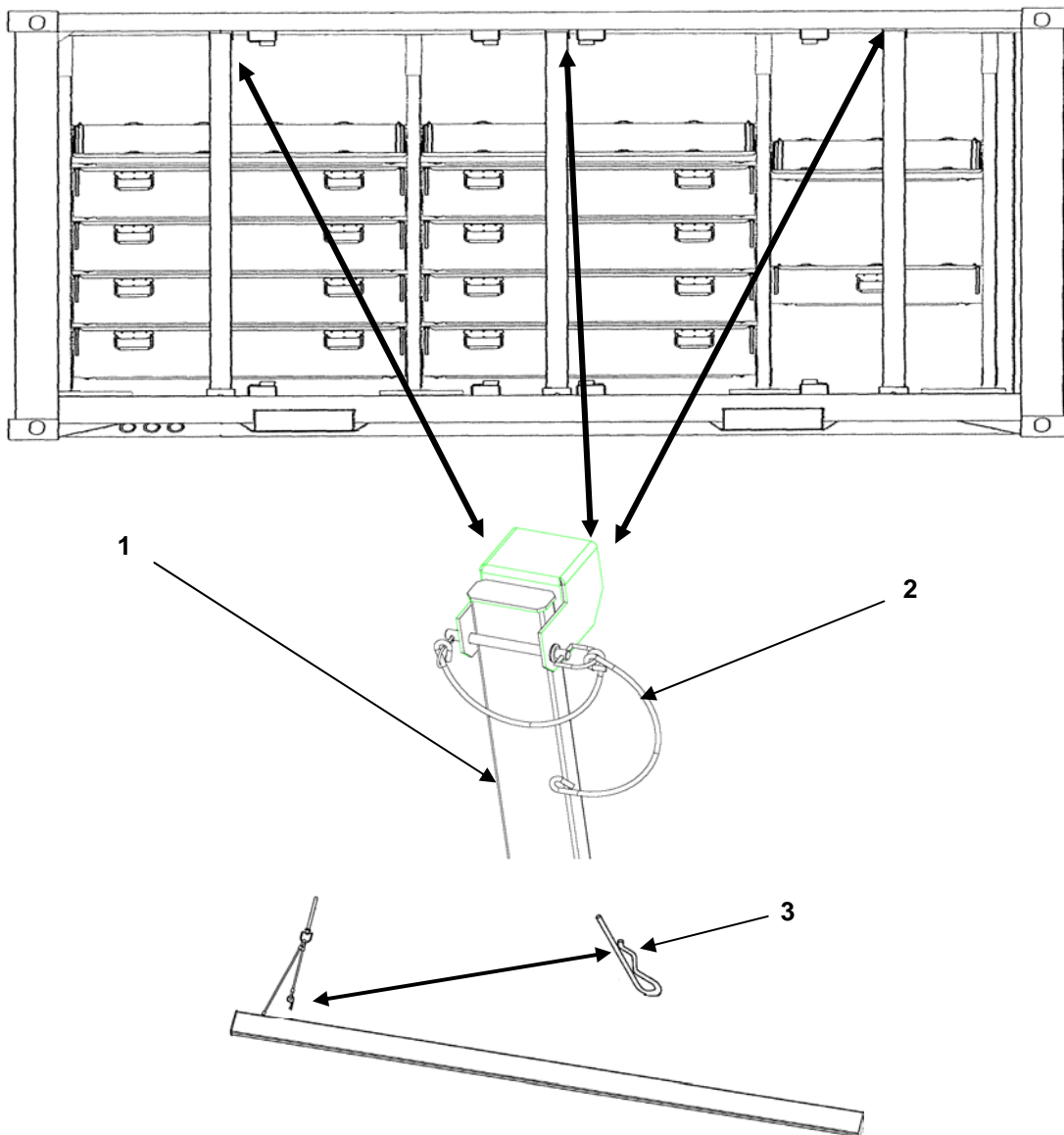

Figure 6. Constraint Bar

(1)	(2)	(3)	(4)	(5)	(6)	(7)
ITEM NO.	SMR CODE	NSN	CAGEC	PART NUMBER	DESCRIPTION AND USABLE ON CODE (UOC)	QTY
					GROUP 010401 CONSTRAINT BAR FIG. 6 CONSTRAINT BAR	
1	PAOOO	5411-01-529-8382	1NSG3	16501289-001	BAR, LOAD CONSTRAINT UOC: FTR	3
	PAOOO	5411-01-529-8384	1NSG3	16501289-002	BAR, LOAD CONSTRAINT UOC: FTT	3
2	PAOOO	5411-01-529-8385	1NSG3	15120662	.PIN ASSY W/ LANYARDS UOC: FTR, FTT	1
3	XDOZZ		07BY4	98335A065	..PIN, HAIRPIN COTTER UOC: FTR, FTT	1
END OF FIGURE						

OPERATOR'S, UNIT AND DIRECT SUPPORT MAINTENANCE

AUTHORIZED STOCKAGE LIST MOBILITY SYSTEM (ASLMS)

MODEL NUMBER FPU-8/12 PARTS (OD) P/N 15005002-001
NSN 5411-01-523-2071

MODEL NUMBER FPU-8/12 PARTS (DS) P/N 15005002-002
NSN 5411-01-523-2072

MODEL NUMBER FPU-8/12 BULK (OD) P/N 15005001-001
NSN 5411-01-523-2073

MODEL NUMBER FPU-8/12 BULK (DS) P/N 15005001-002
NSN 5411-01-523-2074

DRAWER ASSEMBLIES

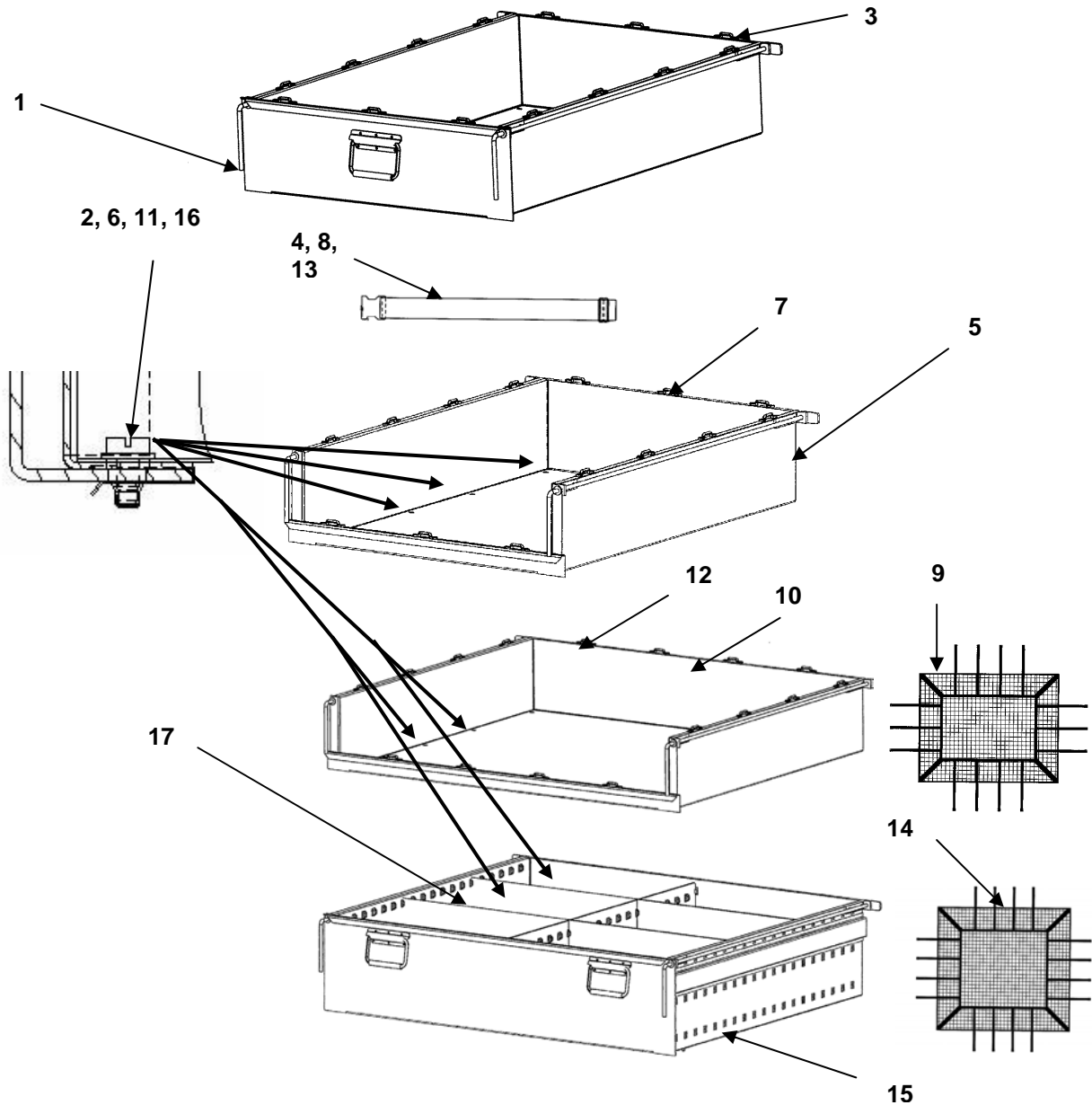

Figure 7. Drawer Assemblies

(1) ITEM NO.	(2) SMR CODE	(3) NSN	(5) PART NUMBER	(6) DESCRIPTION AND USABLE ON CODE (UOC)	(7) QTY
				GROUP 010402 DRAWER ASSEMBLIES FIG. 7 DRAWER ASSEMBLIES	
1	PAOOO	5411-01-529-8385	1NSG3 16503250-001	DRAWER ASSY 8" UOC: FTR	1
	PAOOO	5411-01-529-8317	1NSG3 16503250-002	DRAWER ASSY 8" UOC: FTT	1
2	XDOZZ		1NSG3 15121054	.SCREW, FLANGE HEAD UOC: FTR, FTT	8
3	XDOZZ		76735 AH6411BZN	.LOOP, STRAP ATTACHING UOC: FTR, FTT	14
4	PAOZZ	5411-01-529-8316	1NSG3 16501613	.STRAP, ATTACHING, NET UOC: FTR, FTT	14
5	PAOOO	5411-01-529-8318	1NSG3 16502050-001	DRAWER 2" SMALL OD UOC: FTR	1
	PAOOO	5411-01-529-8320	1NSG3 16502050-002	DRAWER 2" SMALL OD UOC: FTT	1
6	XDOZZ		1NSG3 15121054	.SCREW FLANGE HEAD UOC: FTR, FTT	8
7	XDOZZ		76735 AH6411BZN	.LOOP, STRAP ATTACHING UOC: FTR, FTT	14
8	PAOZZ	5411-01-529-8316	1NSG3 16501613	.STRAP, ATTACHING, NET UOC: FTR, FTT	14
9	PAOZZ	5411-01-529-8325	1NSG3 16501606	NET, 2" SMALL DRAWER UOC: FTR, FTT	1
10	PAOOO	5411-01-529-8319	1NSG3 16502056-001	DRAWER ASSY 2" MEDIUM OD' UOC: FTR	4
	PAOOO	5411-01-529-8321	1NSG3 16502056-002	DRAWER ASSY 2" MEDIUM DS UOC: FTT	4
11	XDOZZ		1NSG3 15121054	.SCREW FLANGE HEAD UOC: FTR, FTT	8
12	XDOZZ		76735 AH6411BZN	.LOOP, STRAP ATTACHING UOC: FTR, FTT	14
13	PAOZZ	5411-01-529-8316	1NSG3 16501613	.STRAP, ATTACHING, NET UOC: FTR, FTT	14
14	PAOZZ	5411-01-529-8326	1NSG3 16501607	NET, 2" MEDIUM DRAWER UOC: FTR, FTT	1
15	PAOOO	5411-01-530-1011	1NSG3 16504750-001	DRAWER ASSY 12" UOC: FTR	16
	PAOOO	5411-01-529-9196	1NSG3 16504750-002	DRAWER ASSY 12" UOC: FTT	16
16	XDOZZ		1NSG3 15121054	.SCREW FLANGE HEAD UOC: FTR, FTT	8
17	PAOZZ	5411-01-529-9181	1NSG3 16504705	.DIVIDERS, DRAWER UOC: FTR, FTT	2
				END OF FIGURE	

OPERATOR'S, UNIT AND DIRECT SUPPORT MAINTENANCE

AUTHORIZED STOCKAGE LIST MOBILITY SYSTEM (ASLMS)

MODEL NUMBER FPU-8/12 PARTS (OD) P/N 15005002-001

NSN 5411-01-523-2071

MODEL NUMBER FPU-8/12 PARTS (DS) P/N 15005002-002

NSN 5411-01-523-2072

MODEL NUMBER FPU-8/12 BULK (OD) P/N 15005001-001

NSN 5411-01-523-2073

MODEL NUMBER FPU-8/12 BULK (DS) P/N 15005001-002

NSN 5411-01-523-2074

DRAWER SLIDES

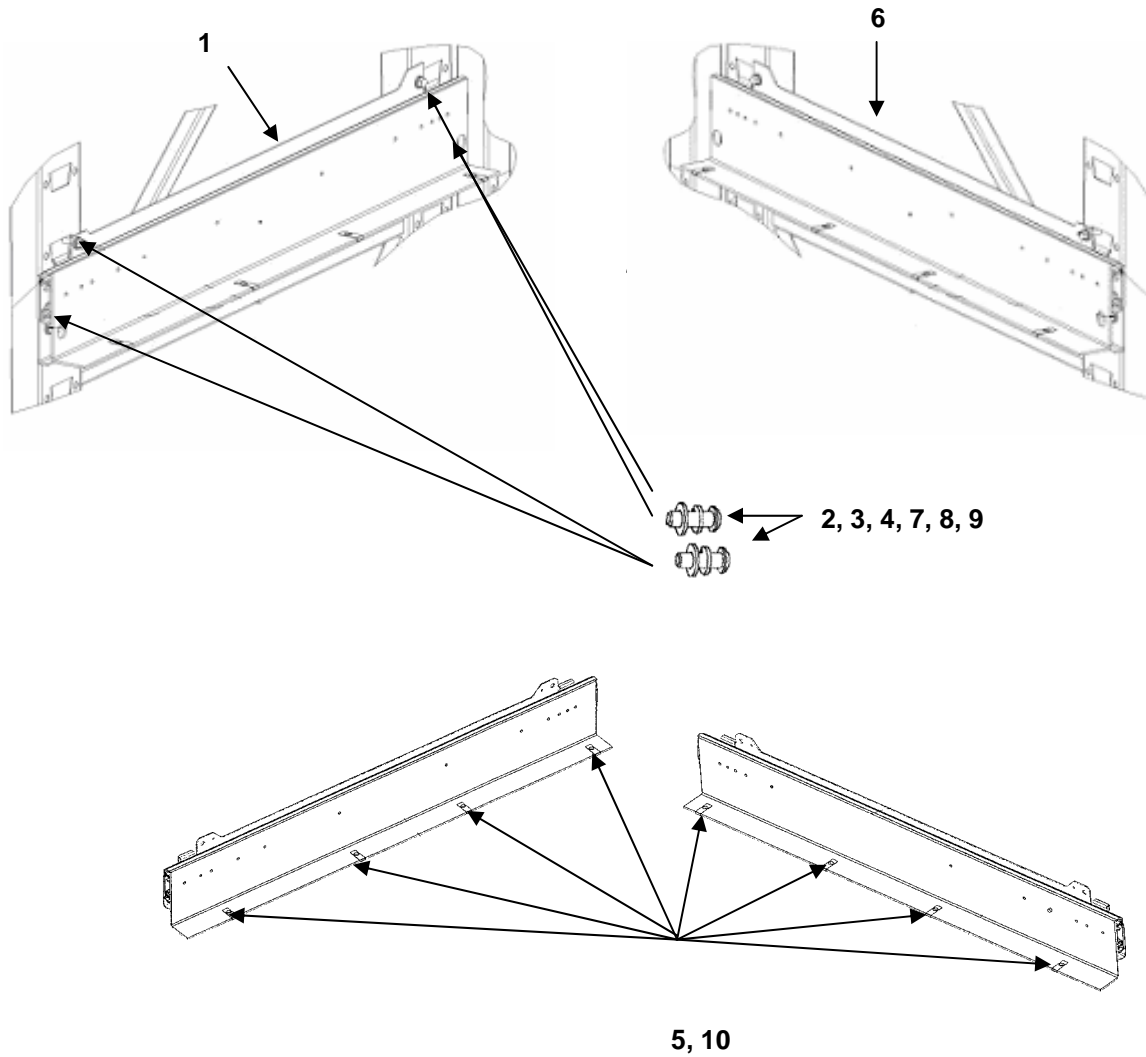

Figure 8. Drawer Slides

(1) ITEM NO.	(2) SMR CODE	(3) NSN	(4) CAGEC	(5) PART NUMBER	(6) DESCRIPTION AND USABLE ON CODE (UOC)	(7) QTY
GROUP 010403 DRAWER SLIDES FIG. 8 DRAWER SLIDES						
1	PAOOO	5411-01-529-9184	1NSG3	16500553	SLIDE, DRAWER LFT UOC: FTR, FTT	1
2	XDOZZ		1RDQ0	3H424	.ALLEN BOLT 5/16" x1" UOC: FTR, FTT	4
3	XDOZZ		1RDQ0	4P503	.WASHER FLAT 5/16" UOC: FTR, FTT	4
4	XDOZZ		1RDQ0	4P530	. WASHER, LOCK 5/16" UOC: FTR, FTT	4
5	XDOZZ		1NSG3	15121055	. SPRING, SHEET CLIP UOC: FTR, FTT	4
6	PAOOO	5411-01-529-9187	1NSG3	16500554	SLIDE, DRAWER RHT UOC: FTR, FTT	1
7	XDOZZ		1RDQ0	3H424	.ALLEN BOLT 5/16" x1" UOC: FTR, FTT	4
8	XDOZZ		1RDQ0	4P503	.WASHER FLAT 5/16" UOC: FTR, FTT	4
9	XDOZZ		1RDQ0	4P530	. WASHER, LOCK 5/16" UOC: FTR, FTT	4
10	XDOZZ		1NSG3	15121055	. SPRING, SHEET CLIP UOC: FTR, FTT	4
END OF FIGURE						

OPERATOR'S, UNIT AND DIRECT SUPPORT MAINTENANCE

AUTHORIZED STOCKAGE LIST MOBILITY SYSTEM (ASLMS)

MODEL NUMBER FPU-8/12 PARTS (OD) P/N 15005002-001
 NSN 5411-01-523-2071

MODEL NUMBER FPU-8/12 PARTS (DS) P/N 15005002-002
 NSN 5411-01-523-2072

MODEL NUMBER FPU-8/12 BULK (OD) P/N 15005001-001
 NSN 5411-01-523-2073

MODEL NUMBER FPU-8/12 BULK (DS) P/N 15005001-002
 NSN 5411-01-523-2074

PALLET/CARGO NETS

NOTE: DOORS OPEN FOR CLARITY

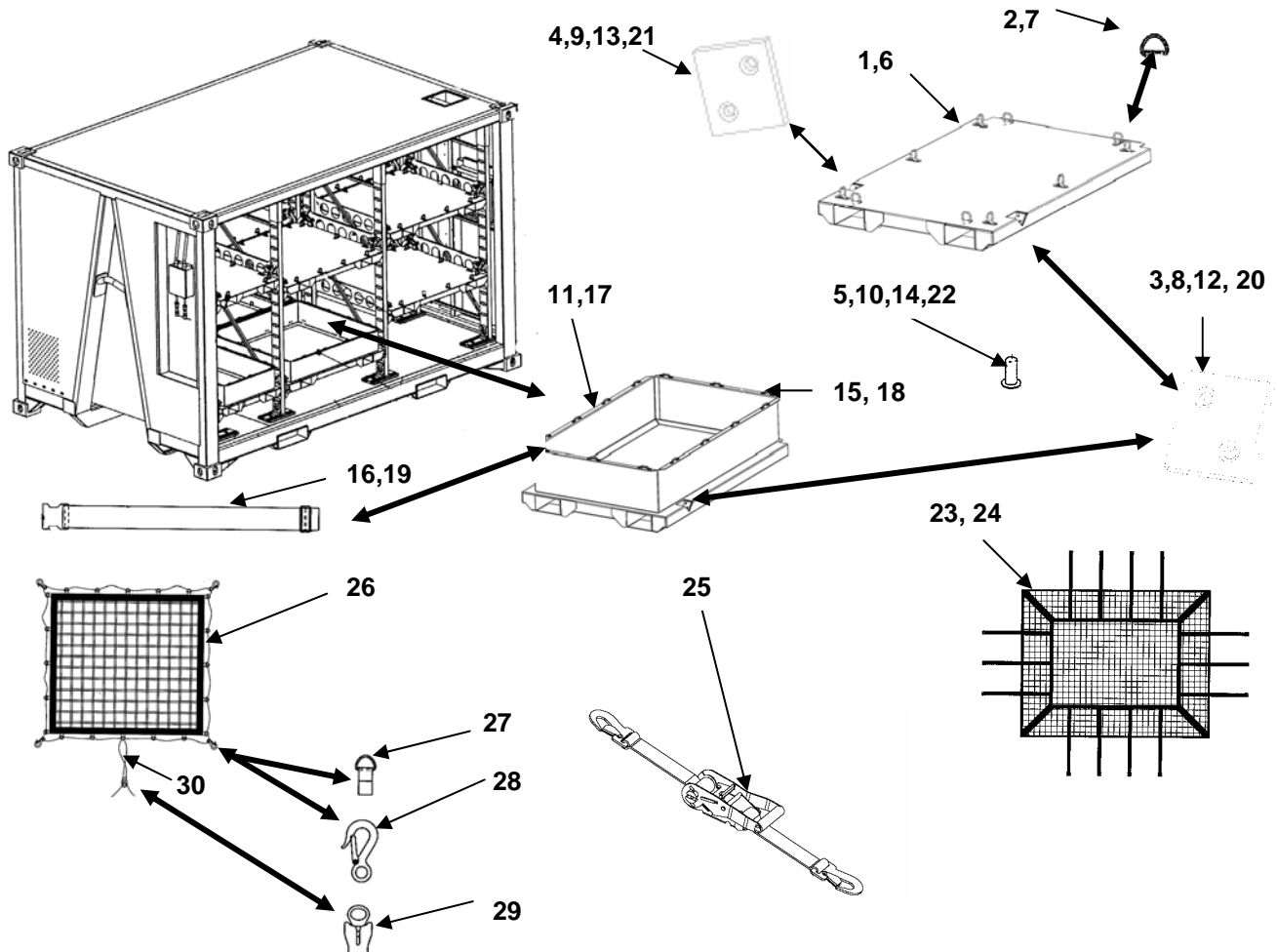

Figure 9. Pallet/Cargo Nets

(1)	(2)	(3)	(4)	(5)	(6)	(7)
ITEM NO.	SMR CODE	NSN	CAGEC	PART NUMBER	DESCRIPTION AND USABLE ON CODE (UOC)	QTY
					GROUP 010501 PALLET/CARGO NETS FIG. 9 PALLET/CARGO NETS	
1	PAOFF	5411-01-529-9192	1NSG3	16503050-001	PALLET, SMALL 30", OD UOC: FTS	1
	PAOFF	5411-01-529-9186	1NSG3	16503050-002	PALLET, SMALL 30", DS UOC: FTU	1
2	XDFZZ		7B735	700 ZN	.D RING WELDED	10
3	PAFZZ	5411-01-529-9216	1NSG3	16503544	.PAD, LOCK ROD RT UOC: FTS, FTU	1
4	PAFZZ	5411-01-529-9213	1NSG3	16503549	.PAD, LOCK ROD LFT UOC: FTS, FTU	1
5	XDFZZ		1RDQ0	4Y114	.RIVET UOC FTS,FTU	4
6	PAOFF	5411-01-529-9195	1NSG3	16504850-001	PALLET, CGO. MED 48", OD UOC: FTS	6
	PAOFF	5411-01-529-9201	1NSG3	16504850-002	PALLET, CGO.MED 48", DS UOC: FTU	6
7	XDFZZ		7B735	700 ZN	.D RING WELDED	14
8	PAFZZ	5411-01-529-9216	1NSG3	16503544	.PAD, LOCK ROD RT UOC: FTS, FTU	1
9	PAFZZ	5411-01-529-9213	1NSG3	16503549	.PAD, LOCK ROD LFT UOC: FTS, FTU	1
10	XDFZZ		1RDQ0	4Y114	.RIVET UOC: FTS, FTU	4
11	PAOFF	5411-01-529-9207	1NSG3	16504950-001	PALLET, HAZMAT 48", OD UOC: FTS	2
	PAOFF	5411-01-529-9208	1NSG3	16504950-002	PALLET, HAZMAT 48", DS UOC: FTU	2
12	PAFZZ	5411-01-529-9216	1NSG3	16503544	.PAD, LOCK ROD RT UOC: FTS, FTU	1
13	PAFZZ	5411-01-529-9213	1NSG3	16503549	.PAD, LOCK ROD LFT UOC: FTS, FTU	1
14	XDFZZ		1RDQ0	4Y114	.RIVET UOC: FTS, FTU	4

(1)	(2)	(3)	(4)	(5)	(6)	(7)
ITEM NO.	SMR CODE	NSN	CAGEC	PART NUMBER	DESCRIPTION AND USABLE ON CODE (UOC)	QTY
15	XDFZZ		76735	AH6411BZN	.LOOP, STRAP ATTACHING UOC: FTS, FTU	16
16	PAOZZ	5411-01-529-8316	1NSG3	16501613	.STRAP, ATTACHING, NET	16
17	PAOFF	5411-01-529-9204	1NSG3	16503150-001	PALLET, HAZMAT 30 “ UOC: FTS	1
	PAOFF	5411-01-529-9210	1NSG3	16503150-002	PALLET, HAZMAT 30 “ UOC: FTU	1
18	XDFZZ		76735	AH6411BZN	.LOOP, STRAP ATTACHING UOC: FTS, FTU	14
19	PAOZZ	5411-01-529-8316	1NSG3	16501613	.STRAP, ATTACHING, NET	14
20	PAFZZ	5411-01-529-9216	1NSG3	16503544	.PAD, LOCK ROD RT UOC FTS, FTU	1
21	PAFZZ	5411-01-529-9213	1NSG3	16503549	.PAD, LOCK ROD LFT UOC: FTS, FTU	1
22	XDFZZ		1RDQ0	4Y114	.RIVET UOC: FTS, FTU	4
23	PAOZZ	5411-01-529-9211	1NSG3	16501605	NET, CARGO HAZMAT 48" UOC: FTS, FTU	2
24	PAOZZ	5411-01-529-9219	1NSG3	16501604	NET, CARGO HAZMAT 30" UOC: FTS, FTU	1
25	XDOZZ		1NSG3	15240152	STRAPS RATCHET UOC: FTS, FTR	36
26	PAOZZ	5411-01-529-9217	1NSG3	16501610	NET, FLOOR CGO 48" UOC: FTS, FTU	4
27	XDFZZ		07BY4	3648T73	.D RING, 1"	20
28	XDOZZ		75535	1023056	.HOOK, SAFETY SNAP	4
29	XDOZZ		06QB1	586552	.CORD CLOSURE	1
30	MOOZZ		63806	G603CAM-00-000	CORD, CAMO 1/4	1
END OF FIGURE						

OPERATOR'S, UNIT AND DIRECT SUPPORT MAINTENANCE

AUTHORIZED STOCKAGE LIST MOBILITY SYSTEM (ASLMS)

MODEL NUMBER FPU-8/12 PARTS (OD) P/N 15005002-001

NSN 5411-01-523-2071

MODEL NUMBER FPU-8/12 PARTS (DS) P/N 15005002-002

NSN 5411-01-523-2072

MODEL NUMBER FPU-8/12 BULK (OD) P/N 15005001-001

NSN 5411-01-523-2073

MODEL NUMBER FPU-8/12 BULK (DS) P/N 15005001-002

NSN 5411-01-523-2074

PALLET LEDGE

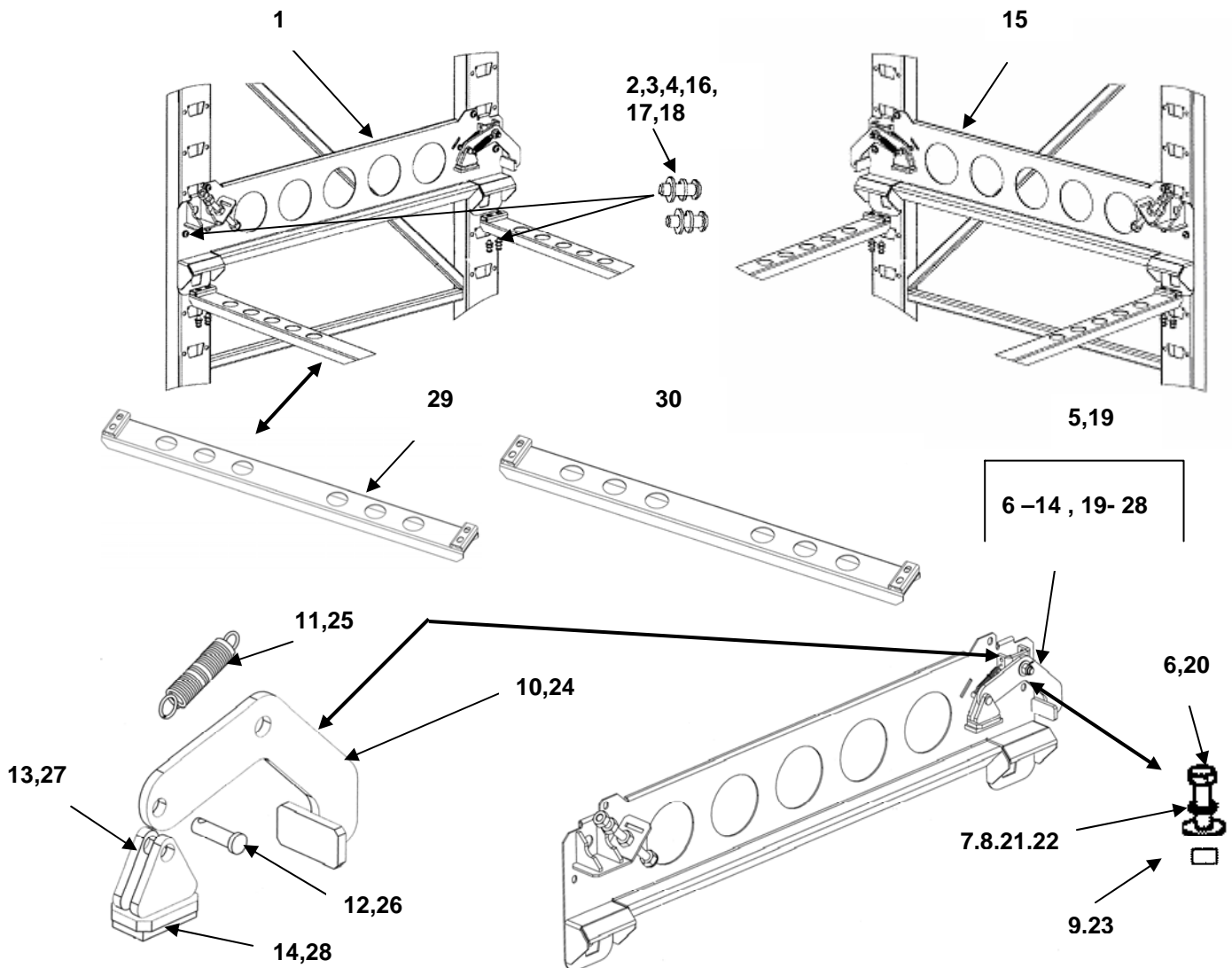

Figure 10. Pallet Ledge

(1) ITEM NO.	(2) SMR CODE	(3) NSN	(4) CAGEC	(5) PART NUMBER	(6) DESCRIPTION AND USABLE ON CODE (UOC)	(7) QTY
					GROUP 010502 PALLET LEDGE FIG. 10 PALLET LEDGE	
1	PAOOO	5411-01-529-9218	INSG3	16503559-001	PALLET LEDGE LFT OD UOC: FTS	12
	PAOOO	5411-01-529-9224	1NSG3	16503559-002	PALLET LEDGE LFT DS UOC: FTU	12
2	XDOZZ		1RDQ0	3H424	.BOLT, ALLEN 5/16" x1"	8
3	XDOZZ		1RDQ0	4P530	.WASHER, LOCK 5/16"	8
4	XDOZZ		1RDQ0	4P503	.WASHER, FLAT 5/16"	8
5	PAOZZ	5411-01-529-9229	1NSG3	16503561-001	.LOCKS, CAM ASSY OD UOC: FTS	1
	PAOZZ	5411-01-529-9230	1NSG3	16503561-002	.LOCKS, CAM ASSY DS UOC: FTS	1
6	XDOZZ		1RDQ0	2X672	..BOLT, SHOULDER	1
7	XDOZZ		1RDQ0	4P533	..WASHER, FLAT	1
8	XDOZZ		07BY4	90295A170	..WASHER, NYLON	1
9	XDOZZ		1RDQ0	4P434	..NUT LOCK	1
10	XDOZZ		1NSG3	16503563-001	..LOCK CAM ARM OD UOC: FTS	1
	XDOZZ		1NSG3	16503563-002	..LOCK CAM ARM DS UOC: FTU	1
11	XDOZZ		56048	E0500-069-2750	..SPRING, EXTENSION	1
12	XDOZZ		07BY4	92390A271	..PIN, CLEVIS 3/8 X 1 1/4	1
13	XDOZZ		1NSG3	16503562-001	..CAM FOOT UOC: FTS	1
	XDOZZ		1NSG3	16503562-002	..CAM FOOT UOC: FTU	1
14	XDOZZ		1NSG3	16503521	...PAD RUBBER	1
15	PAOOO	5411-01-529-9221	INSG3	16503560-001	PALLET LEDGE RHT OD UOC: FTS	12
	PAOOO	5411-01-529-9227	INSG3	16503560-002	PALLET LEDGE RHT DS UOC: FTU	12
16	XDOZZ		1RDQ0	3H424	.BOLT, ALLEN 5/16" x1"	8
17	XDOZZ		1RDQ0	4P530	.WASHER, LOCK 5/16"	8
18	XDOZZ		1RDQ0	4P503	.WASHER, FLAT 5/16"	8
19	PAOZZ	5411-01-529-9229	1NSG3	16503561-001	.LOCKS, CAM ASSY OD UOC: FTS	1
	PAOZZ	5411-01-529-9230	1NSG3	16503561-002	.LOCKS, CAM ASSY DS UOC: FTS	1

(1)	(2)	(3)	(4)	(5)	(6)	(7)
ITEM NO.	SMR CODE	NSN	CAGEC	PART NUMBER	DESCRIPTION AND USABLE ON CODE (UOC)	QTY
20	XDOZZ		1RDQ0	2X672	..BOLT, SHOULDER	1
21	XDOZZ		1RDQ0	4P533	..WASHER, FLAT	1
22	XDOZZ		07BY4	90295A170	..WASHER, NYLON	1
23	XDOZZ		1RDQ0	4P434	..NUT LOCK	1
24	XDOZZ		1NSG3	16503563-001	..LOCK CAM ARM OD UOC: FTS	1
	XDOZZ		1NSG3	16503563-002	..LOCK CAM ARM DS UOC: FTU	1
25	XDOZZ		56048	E0500-069-2750	..SPRING EXTENSION	1
26	XDOZZ		07BY4	92390A271	..PIN, CLEVIS 3/8 X 1 1/4	1
27	XDOZZ		1NSG3	16503562-001	..CAM FOOT UOC: FTS	1
	XDOZZ		1NSG3	16503562-002	..CAM FOOT UOC: FTU	1
28	XDOZZ		1NSG3	16503521	...PAD RUBBER	1
29	PAOZZ	5411-01-529-9226	1NSG3	16503572-001	HORIZ STABILIZER, 30", OD	8
	PAOZZ		1NSG3	16503572-002	HORIZ STABILIZER, 30", DS	8
30	PAOZZ	5411-01-529-9228	1NSG3	16503573-001	HORIZ STABILIZER, 48", OD	16
	PAOZZ	5411-01-529-9232	1NSG3	16503573-002	HORIZ STABILIZER, 48", DS	16

END OF FIGURE

OPERATOR'S, UNIT AND DIRECT SUPPORT MAINTENANCE

AUTHORIZED STOCKAGE LIST MOBILITY SYSTEM (ASLMS)

MODEL NUMBER FPU-8/12 PARTS (OD) P/N 15005002-001

NSN 5411-01-523-2071

MODEL NUMBER FPU-8/12 PARTS (DS) P/N 15005002-002

NSN 5411-01-523-2072

MODEL NUMBER FPU-8/12 BULK (OD) P/N 15005001-001

NSN 5411-01-523-2073

MODEL NUMBER FPU-8/12 BULK (DS) P/N 15005001-002

NSN 5411-01-523-2074

FPU-8 CONTAINER PARTS AND BULK

NOTE: DOORS OPEN FOR CLARITY

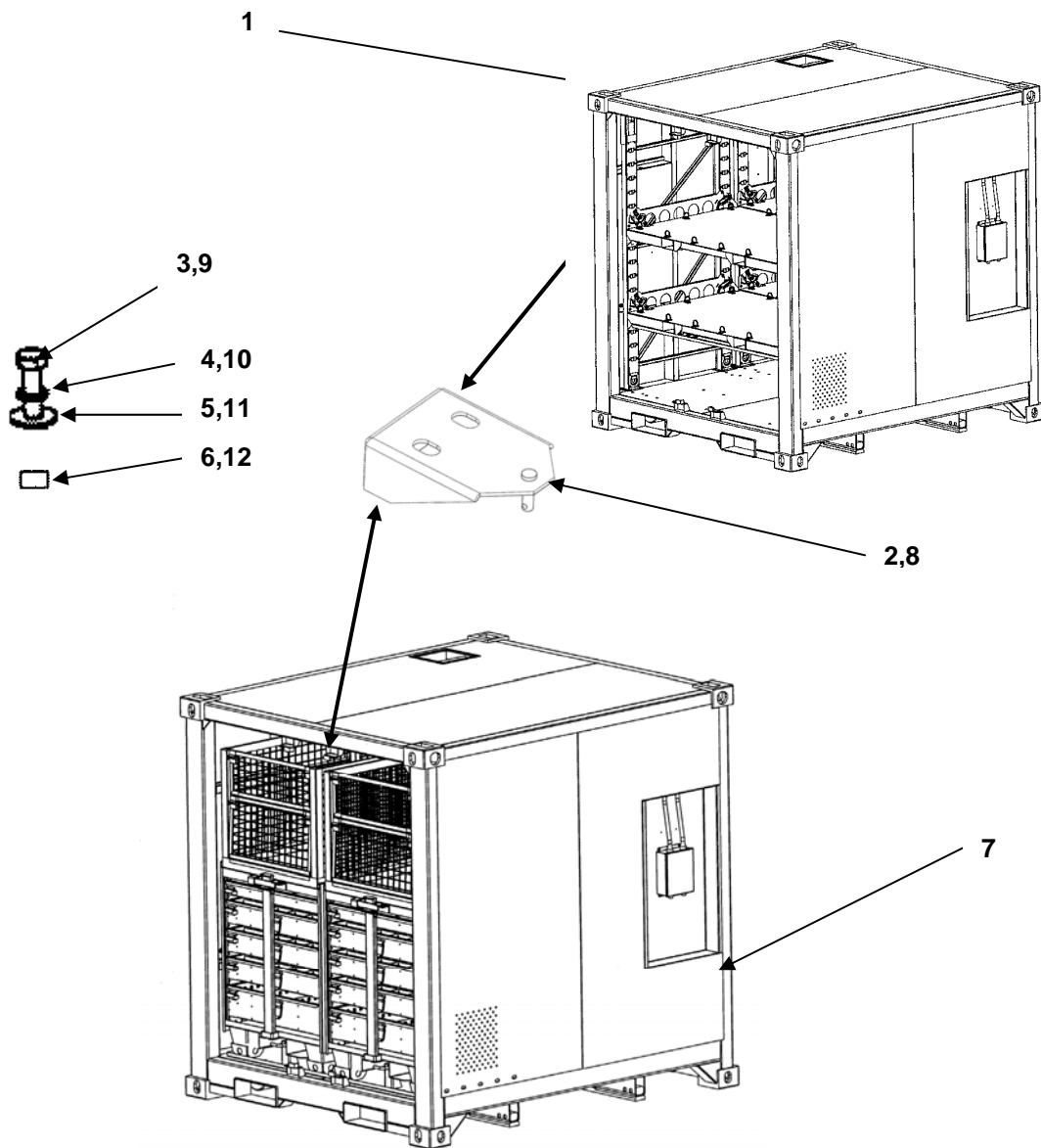

Figure 11. FPU-8 Container Parts and Bulk

(1) ITEM NO.	(2) SMR CODE	(3) NSN	(4) CAGEC	(5) PART NUMBER	(6) DESCRIPTION AND USABLE ON CODE (UOC)	(7) QTY
GROUP 02 FPU-8 CONTAINER PARTS AND BULK						
FIG. 11 FPU-8 CONTAINER PARTS AND BULK						
1	PAFFF	5411-01-529-9238	1NSG3	15005012- 001	FPU-8-BULK OD UOC: FTS	1
	PAFFF	5411-01-529-9225	1NSG3	15005012- 002	FPU-8-BULK DS UOC: FTU	1
2	PAOZZ	5411-01-529-8333	1NSG3	16501861-001	.EPC BRACKET OD UOC: FTR, FTS	2
	PAOZZ	5411-01-529-8334	1NSG3	16501861-002	.EPC BRACKET DS UOC: FTT, FTU	2
3	XDOZZ		1RDQ0	2M014	..BOLT, HEXHD ½ 13 X 1	2
4	XDOZZ		1RDQ0	2V106	..WASHER LOCK 1/2	2
5	XDOZZ		1RDQ0	4P533	..WASHER FLAT HVY ½"	2
6	XDOZZ		07BY4	3259T19	..UNI STRUT NUT	2
7	PAFFF	5411-01-529-9231	1NSG3	15005015- 001	FPU-8-PARTS OD UOC: FTR	1
	PAFFF	5411-01-529-9234	1NSG3	15005015- 002	FPU-8-PARTS DS UOC: FTT	1
8	PAOZZ	5411-01-529-8333	1NSG3	16501861-001	.EPC BRACKET OD UOC: FTR, FTS	2
	PAOZZ	5411-01-529-8334	1NSG3	16501861-002	.EPC BRACKET DS UOC: FTT, FTU	2
9	XDOZZ		1RDQ0	2M014	..BOLT, HEXHD ½ 13 X 1	2
10	XDOZZ		1RDQ0	2V106	..WASHER LOCK 1/2	2
11	XDOZZ		1RDQ0	4P533	..WASHER FLAT HVY ½"	2
12	XDOZZ		07BY4	3259T19	..UNI STRUT NUT	2
END OF FIGURE						

OPERATOR'S, UNIT AND DIRECT SUPPORT MAINTENANCE

AUTHORIZED STOCKAGE LIST MOBILITY SYSTEM (ASLMS)

MODEL NUMBER FPU-8/12 PARTS (OD) P/N 15005002-001

NSN 5411-01-523-2071

MODEL NUMBER FPU-8/12 PARTS (DS) P/N 15005002-002

NSN 5411-01-523-2072

MODEL NUMBER FPU-8/12 BULK (OD) P/N 15005001-001

NSN 5411-01-523-2073

MODEL NUMBER FPU-8/12 BULK (DS) P/N 15005001-002

NSN 5411-01-523-2074

DOOR ASSEMBLIES

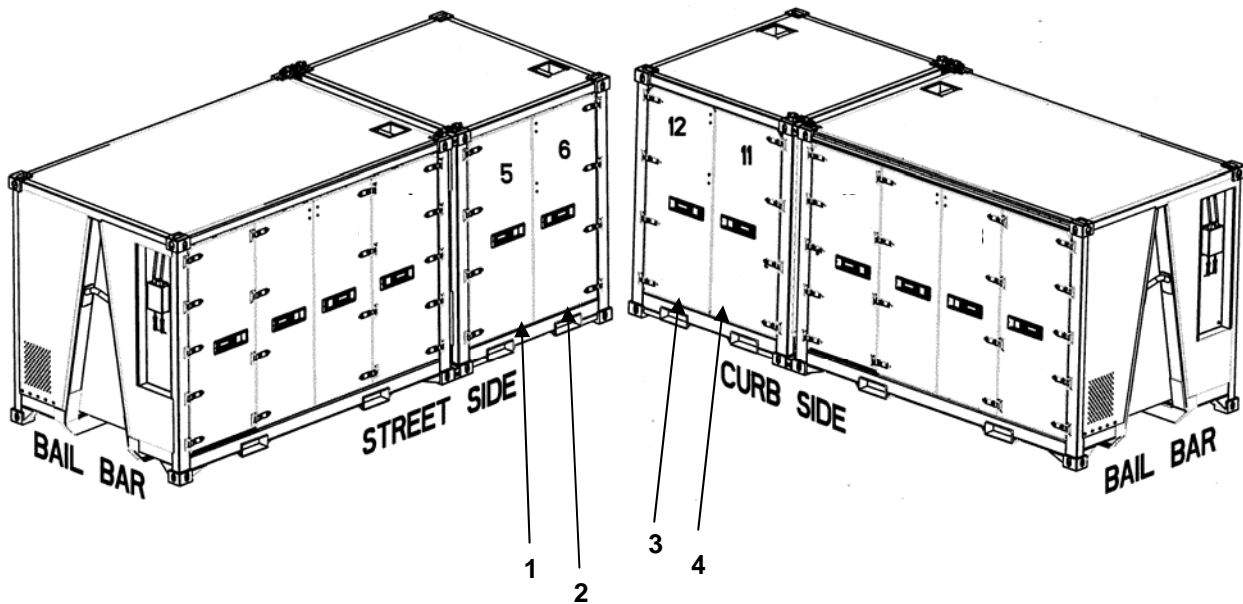

NOTE: FOR REPLACEMENT PARTS GO TO FIGURE 15

Figure 12. Door Assemblies
(Sheet 1 of 2)

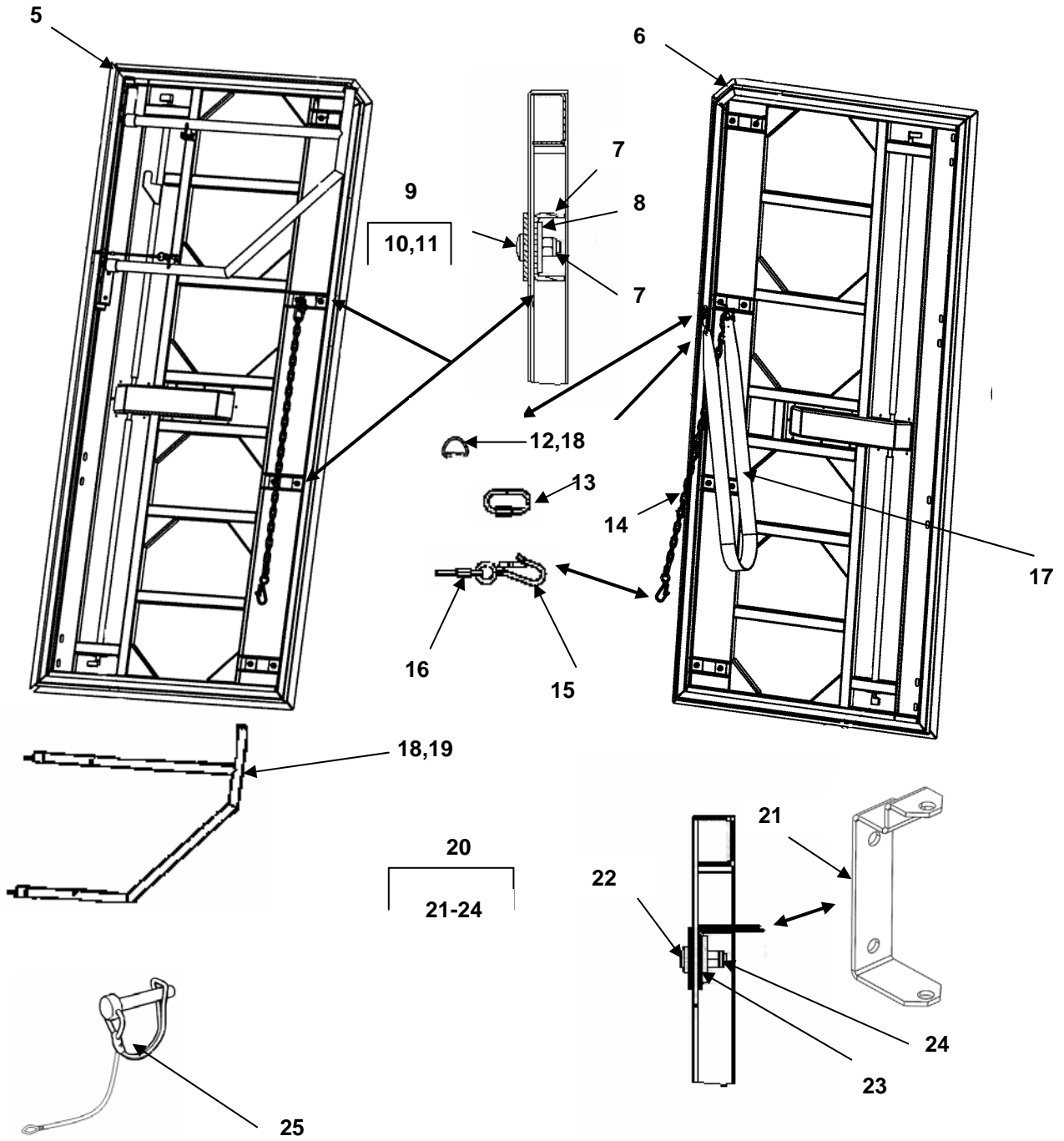

Figure 12. Door Assemblies
(Sheet 2 of 2)

(1)	(2)	(3)	(4)	(5)	(6)	(7)
ITEM NO.	SMR CODE	NSN	CAGEC	PART NUMBER	DESCRIPTION AND USABLE ON CODE (UOC)	QTY
GROUP 0201 DOOR ASSEMBLIES FIG. 12 DOOR ASSEMBLIES						
1	PAFFF	5411-01-530-1026	1NSG3	16505505-001	DOOR ASSY #5 OD UOC: FTR, FTS	1
	PAFFF	5411-01-530-1029	1NSG3	16505505-002	DOOR ASSY #5 DS UOC: FTT, FTU	1
2	PAFFF	5411-01-529-9182	1NSG3	16505506-001	DOOR ASSY #6 OD UOC: FTR, FTS	1
	PAFFF	5411-01-529-9235	1NSG3	16505506-002	DOOR ASSY #6 DS UOC: FTT, FTU	1
3	PAFFF	5411-01-529-9233	1NSG3	16505512-001	DOOR ASSY #12 OD UOC: FTR, FTS	1
	PAFFF	5411-01-529-9236	1NSG3	16505512-002	DOOR ASSY #12 DS UOC: FTT, FTU	1
4	PAFFF	5411-01-529-9241	1NSG3	16505511-001	DOOR ASSY #11 OD UOC: FTR, FTS	1
	PAFFF	5411-01-530-1032	1NSG3	16505511-002	DOOR ASSY #11 DS UOC: FTT, FTU	1
5	PAFZZ	5411-01-530-1042	1NSG3	16505517	.SEAL KIT,DOOR 5&12	1
6	PAFZZ	5411-01-530-0999	1NSG3	16505518	.SEAL KIT,DOOR 6&11	1
7	XDFZZ		1NSG3	16502834-001	.BRACE, HINGE A OD UOC: FTR, FTS	4
	XDFZZ		1NSG3	16502834-002	.BRACE, HINGE A DS UOC: FTT, FTU	4
8	XDFZZ		1NSG3	16507022	.PLATE, HINGE	8
9	XDFZZ		1NSG3	16505543	.MOUNTING KIT, HINGE	4
10	XDFZZ		1NSG3	15121249	..BOLT, CARRIAGE	8
11	XDFZZ		1RDQ0	4P434	..NUT, LOCKING 3/8X16	8
12	XDFZZ		1NSG3	15940107	D RING, WELD ON, DOOR 2, 3, 8&9	1

(1)	(2)	(3)	(4)	(5)	(6)	(7)
ITEM NO.	SMR CODE	NSN	CAGEC	PART NUMBER	DESCRIPTION AND USABLE ON CODE (UOC)	QTY
13	XDOZZ		07BY4	3712T23	.THREADED CONNECTOR, PEAR SHAPE	1
14	XDOZZ		1NSG3	16504253	.DOOR RESTRAINT, CHAIN ASSEMBLY, DOOR 5&11	1
15	XDOZZ		75535	1023056	..HOOK, SAFETY SNAP	2
16	XDOZZ		1RDQ0	4J199	..CONNECTOR, THREADED	1
17	XDOZZ		1NSG3	16504255	.DOOR RESTRAINT, STRAP ASSEMBLY, DOOR 5&11	
18	PAOZZ	5411-01-529-9237	1NSG3	16501897-001	.POLE, DAVIT SS OD, DOOR 6 UOC: FTR, FTS	1
	PAOZZ	5411-01-529-9240	1NSG3	16501897-002	.POLE, DAVIT SS DS, DOOR 6 UOC: FTT, FTU	1
19	PAOZZ	5411-01-529-9239	1NSG3	16501887-001	.POLE, DAVIT CS, OD DOOR 12 UOC: FTR, FTS	1
	PAOZZ	5411-01-529-9242	1NSG3	16501887-002	.POLE, DAVIT CS, DS DOOR 12 UOC: FTT, FTU	1
20	PAOZZ	5411-01-529-9174	1NSG3	16505548-001	.BRACKET, DAVIT KT DR 6&12 UOC: FTR, FTS	1
	PAOZZ	5411-01-529-9173	1NSG3	16505548-002	.BRACKET, DAVIT KT, DR 6&12 UOC: FTT, FTU	1
21	XDOZZ		1NSG3	16501818-001	.BRACKET, EPC, OD UOC: FTR, FTS	2
	XDOZZ		1NSG3	16501818-002	.BRACKET, EPC, DS UOC: FTT, FTU	2
22	XDOZZ		1RDQ0	2M498	.BOLT, CARRIAGE	2
23	XDOZZ		1RDQ0	4P531	.WASHER FLAT 3/8	2
24	XDOZZ		1RDQ0	4P434	.NUT, LOCKING 3/8X16	2
25	XDOZZ		1NSG3	16501832	.PIN, DAVIT RETENSION, DOOR 6&12 END OF FIGURE	2

OPERATOR'S, UNIT AND DIRECT SUPPORT MAINTENANCE

AUTHORIZED STOCKAGE LIST MOBILITY SYSTEM (ASLMS)

MODEL NUMBER FPU-8/12 PARTS (OD) P/N 15005002-001

NSN 5411-01-523-2071

MODEL NUMBER FPU-8/12 PARTS (DS) P/N 15005002-002

NSN 5411-01-523-2072

MODEL NUMBER FPU-8/12 BULK (OD) P/N 15005001-001

NSN 5411-01-523-2073

MODEL NUMBER FPU-8/12 BULK (DS) P/N 15005001-002

NSN 5411-01-523-2074

REAR ROLLER ASSEMBLY

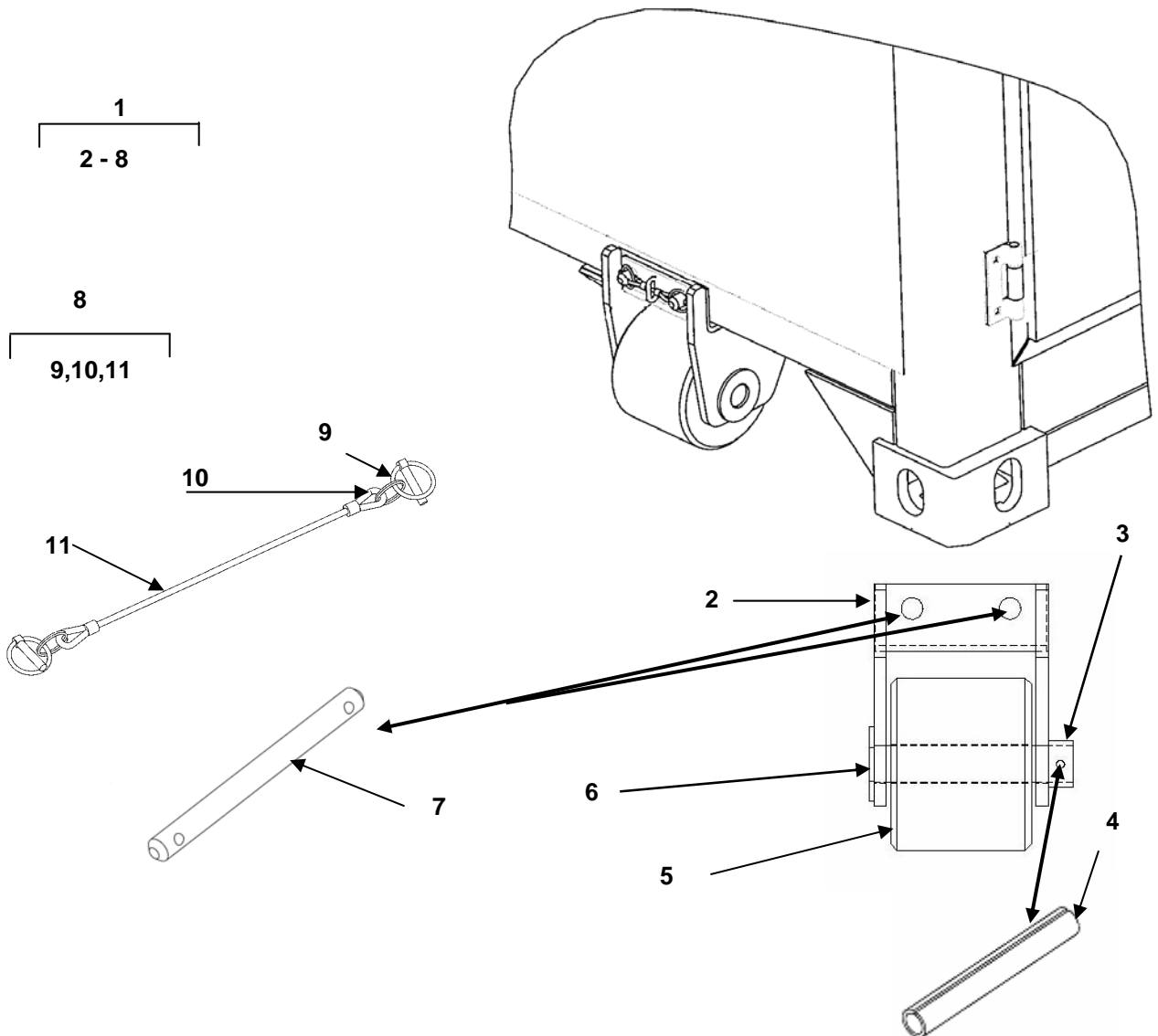

Figure 13. Rear Roller Assembly

(1)	(2)	(3)	(4)	(5)	(6)	(7)
ITEM NO.	SMR CODE	NSN	CAGEC	PART NUMBER	DESCRIPTION AND USABLE ON CODE (UOC)	QTY
					GROUP 0202 REAR ROLLER ASSEMBLY FIG. 13 REAR ROLLER ASSEMBLY	
1	PAOOO	5411-01-529-9172	1NSG3	15310001-001	ROLLER ASSY. OD UOC: FTR, FTS	2
	PAOOO	5411-01-529-9176	1NSG3	15310001-002	ROLLER ASSY. DS UOC: FTT, FTU	2
2	XAOZZ		1NSG3	16500954-001	.FRAME, ROLLER UOC: FTR, FTS	1
	XAOZZ		1NSG3	16500954-002	.FRAME, ROLLER UOC: FTT, FTU	1
3	PAOZZ	5411-01-529-9180	1NSG3	15312286	.COLLAR, ROLLER	1
4	XD0ZZ		07BY4	90692A762	.PIN, SPRING	1
5	PAOZZ	5411-01-529-9177	1NSG3	16500903	.ROLLER, BLACK	1
6	PAOZZ	5411-01-529-9178	1NSG3	16500950	.PIN, ROLLER	1
7	PAOZZ	5411-01-529-9179	1NSG3	16500905	.PIN, ROLLER SECURE	2
8	PAOZZ	5411-01-529-9190	1NSG3	16500955	. PIN ASSY	4
9	XDOZZ		1NSG3	15312262	..LINCHPIN 1/4	2
10	XDOZZ		07BY4	90177A217	..RING SPLIT 7/8"	2
11	XDOZZ		1NSG3	16500907	..LANYARD	1
END OF FIGURE						

OPERATOR'S, UNIT AND DIRECT SUPPORT MAINTENANCE

AUTHORIZED STOCKAGE LIST MOBILITY SYSTEM (ASLMS)

MODEL NUMBER FPU-8/12 PARTS (OD) P/N 15005002-001

NSN 5411-01-523-2071

MODEL NUMBER FPU-8/12 PARTS (DS) P/N 15005002-002

NSN 5411-01-523-2072

MODEL NUMBER FPU-8/12 BULK (OD) P/N 15005001-001

NSN 5411-01-523-2073

MODEL NUMBER FPU-8/12 BULK (DS) P/N 15005001-002

NSN 5411-01-523-2074

FLOOR ADAPTER PLATE

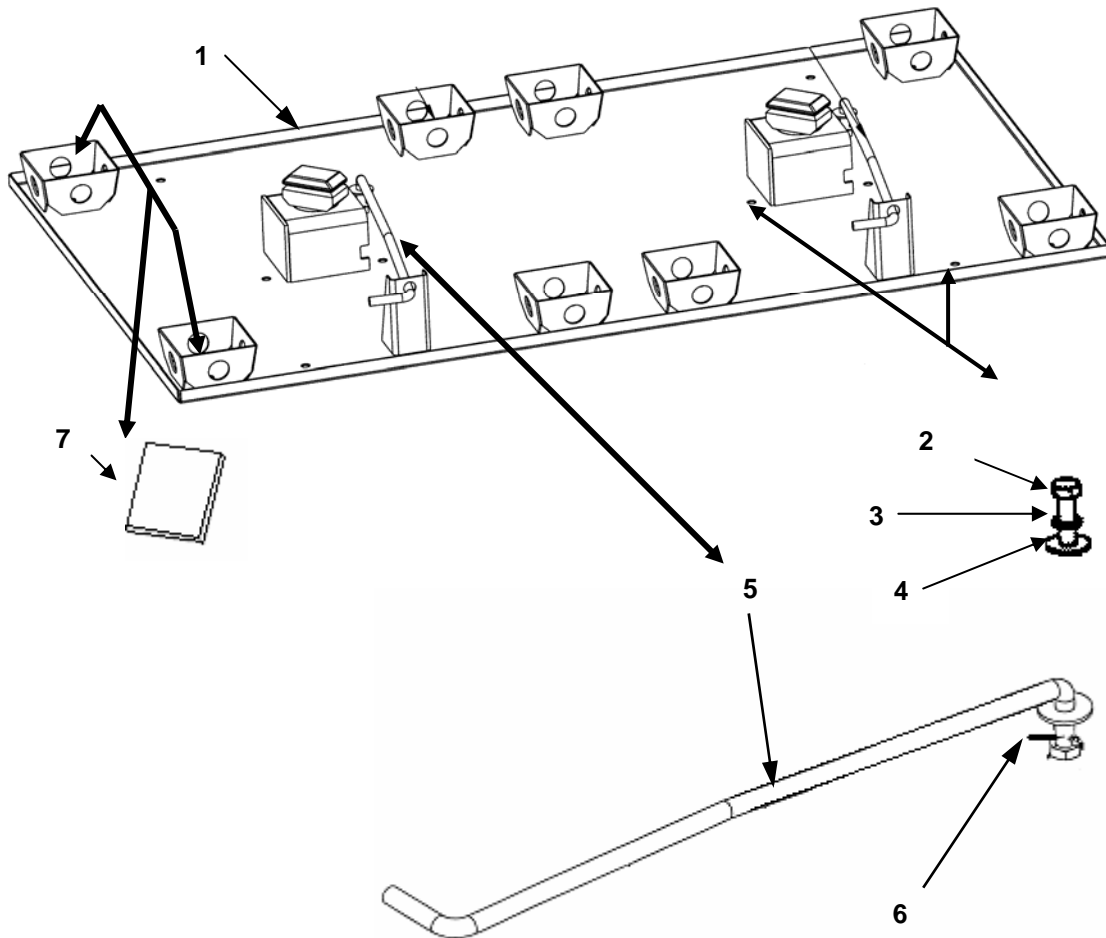

Figure 14. Floor Adapter Plate

(1)	(2)	(3)	(4)	(5)	(6)	(7)
ITEM NO.	SMR CODE	NSN	CAGEC	PART NUMBER	DESCRIPTION AND USABLE ON CODE (UOC)	QTY
					GROUP 020301 FLOOR ADAPTER PLATE FIG. 14 FLOOR ADAPTER PLATE	
1	PAOOO	5411-01-529-9193	1NSG3	16501350-001	FLOOR ADAPTER PLATE UOC: FTR	1
	PAOOO	5411-01-529-9199	1NSG3	16501350-002	FLOOR ADAPTER PLATE UOC: FTT	1
2	XDOZZ		1RDQ0	4P286	.MOUNTING BOLTS	12
3	XDOZZ		1RDQ0	2V106	.WASHER, LOCK	12
4	XDOZZ		1RDQ0	4P533	.WASHER FLAT	12
5	PAOZZ	5411-01-529-9183	1NSG3	16210014-001	.HANDLE LOCKING OD UOC: FTR	2
	PAOZZ	5411-01-530-1033	1NSG3	16210014-002	.HANDLE LOCKING DS UOC: FTT	2
6	XDOZZ		1RDQ0	4P799	..COTTER PIN	1
7	XDOZZ		1NSG3	16501304	.PAD, MODULE FOOT, RCVR	16
END OF FIGURE						

OPERATOR'S, UNIT AND DIRECT SUPPORT MAINTENANCE

AUTHORIZED STOCKAGE LIST MOBILITY SYSTEM (ASLMS)

MODEL NUMBER FPU-8/12 PARTS (OD) P/N 15005002-001

NSN 5411-01-523-2071

MODEL NUMBER FPU-8/12 PARTS (DS) P/N 15005002-002

NSN 5411-01-523-2072

MODEL NUMBER FPU-8/12 BULK (OD) P/N 15005001-001

NSN 5411-01-523-2073

MODEL NUMBER FPU-8/12 BULK (DS) P/N 15005001-002

NSN 5411-01-523-2074

ASLMS MODULE

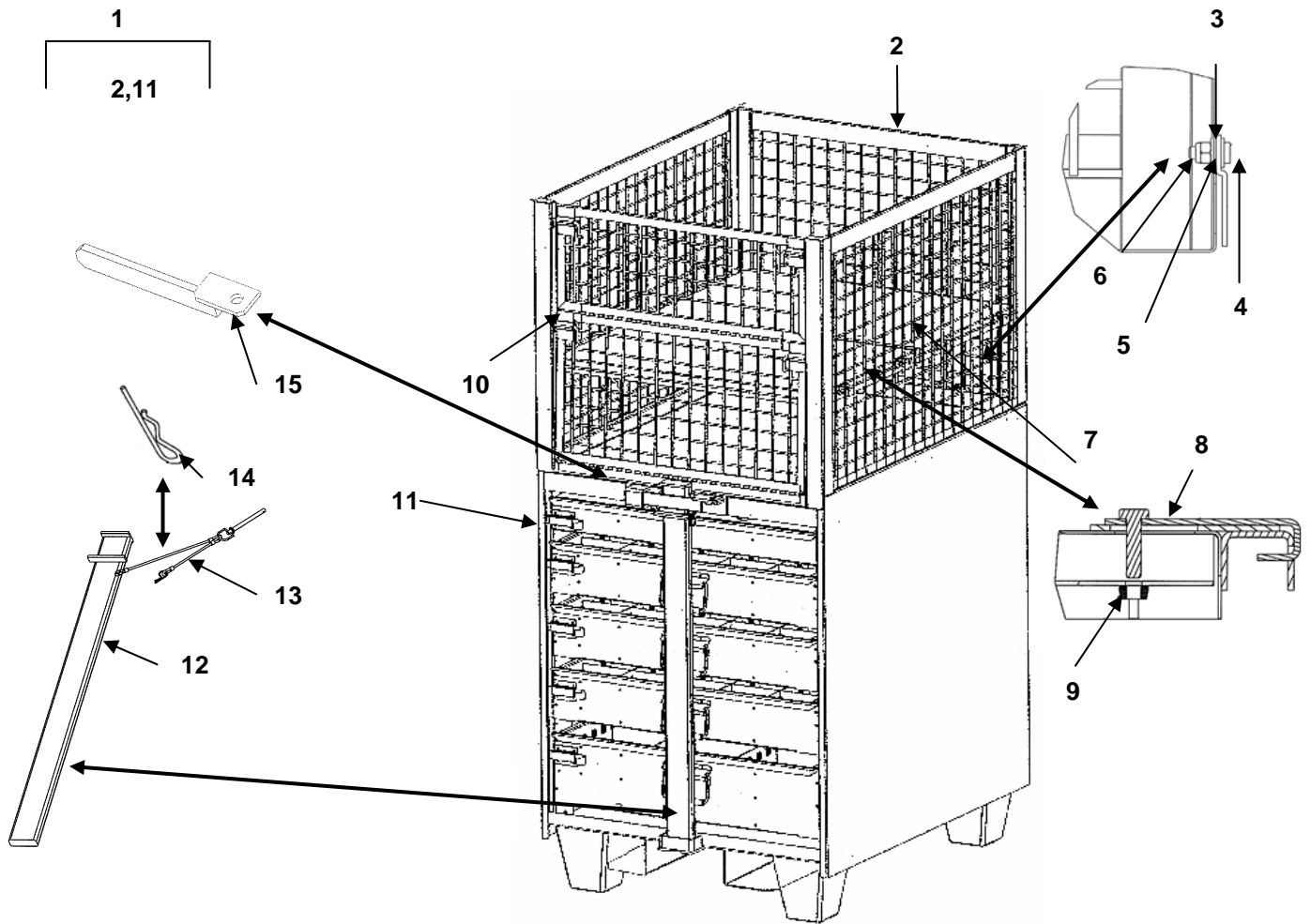
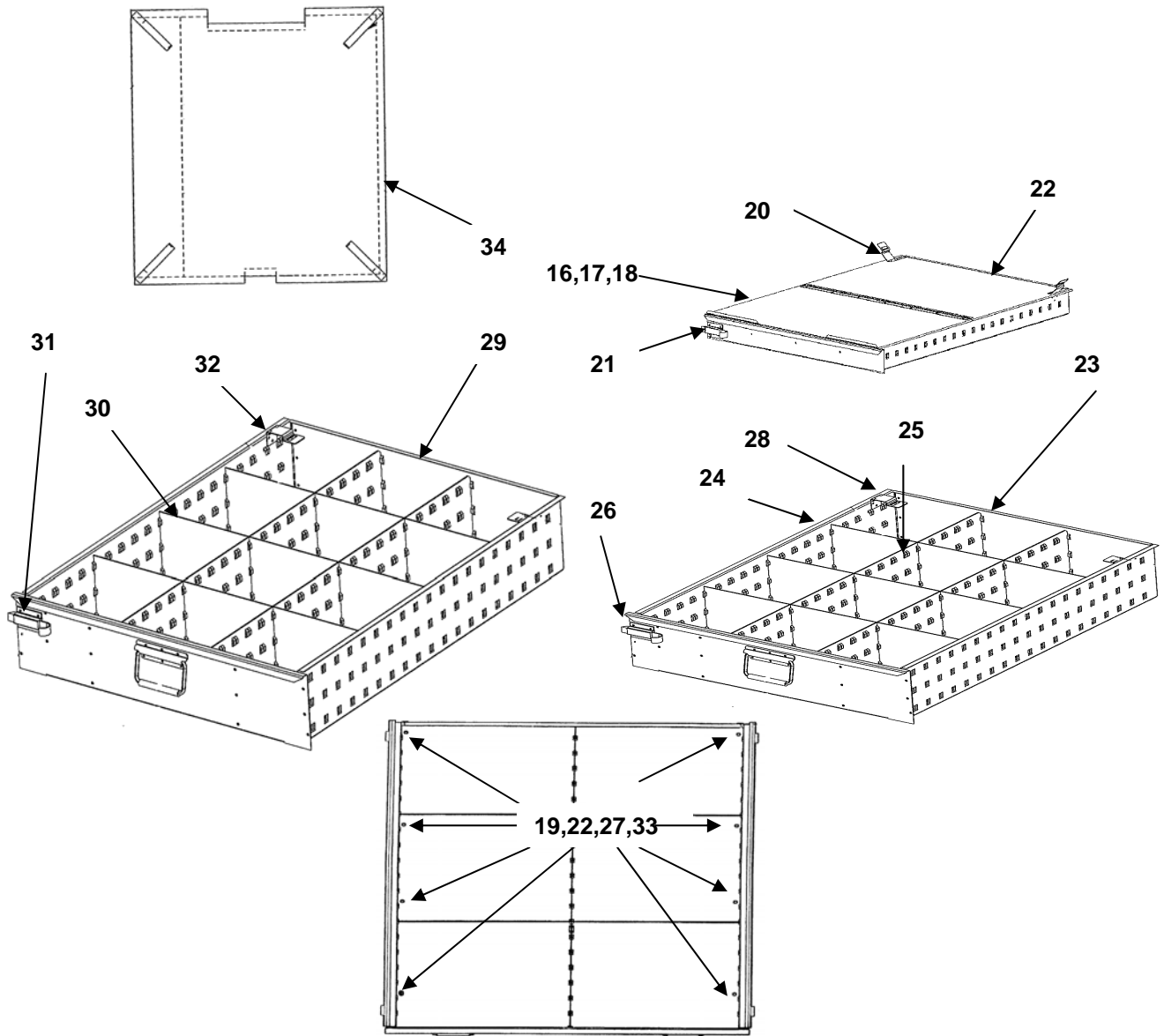

Figure 15. ASLMS Module
(Sheet 1 of 2)



NOTE: TOP VIEW OF SCREW HOLES FOR ALL MODULE DRAWERS

**Figure 15. ASLMS Module
(Sheet 2 of 2)**

(1)	(2)	(3)	(4)	(5)	(6)	(7)
ITEM NO.	SMR CODE	NSN	CAGEC	PART NUMBER	DESCRIPTION AND USABLE ON CODE (UOC)	QTY
					GROUP 020302 ASLMS MODULE FIG. 15 ASLMS MODULE	
1	PAOOO	5411-01-529-9185	1NSG3	15700210-001	MODULE OD UOC: FTR	1
	PAOOO	5411-01-529-9188	1NSG3	15700210-002	MODULE DS UOC: FTT	1
2	PAOOO	5411-01-529-9250	1NSG3	15700212-001	.BASKET OD UOC: FTR	1
	PAOOO	5411-01-529-9251	1NSG3	15700212-002	.BASKET DS UOC: FTR	1
3	XDOZZ		1NSG3	16050132	..TAB, LOCK	2
4	XDOZZ		1RDQ0	4P251	..BOLT, HXHD 1/4"-20X 3/4" GR 8	2
5	XDOZZ		1RDQ0	4P529	..WASHER, FLAT 1/4" GR 8	2
6	XDOZZ		1RDQ0	4P432	..NUT, NYLOCK 1/4" 20	2
7	PAOOO	5411-01-529-9252	1NSG3	16503766-001	..SHELF HALF OD UOC: FTR	2
	PAOOO	5411-01-529-9253	1NSG3	16503766-002	..SHELF HALF DS UOC: FTT	2
8	XDOZZ		1NSG3	16503718-001	...CLAMP, SHELF OD UOC: FTR	4
	XDOZZ		1NSG3	16503718-002	...CLAMP, SHELF DS	4
9	XDOZZ		1RDQ0	4P432	...NUT, WING 1/4" 20	4
10	XDOZZ		1RDQ0	4YF24	..TIE, LOOP, 9"	4
11	PAOOO	5411-01-529-9254	1NSG3	15700211-001	.CABINET MODULE OD UOC: FTR	1
	PAOOO	5411-01-529-9255	1NSG3	15700211-002	.CABINET MODULE DS UOC: FTT	1
12	PAOOO	5411-01-529-9256	1NSG3	16500336-001	.. BAR, 3G RESTRAINT, OD UOC: FTR	1
	PAOOO	5411-01-529-9257	1NSG3	16500336-002	.. BAR, 3G RESTRAIN, DS UOC: FTT	1
13	PAOOO	5411-01-530-1030	1NSG3	15120662	...PIN ASSY W/ LANYARD	1
14	XDOZZ		07BY4	98335A065	...PIN, HAIRPIN COTTER UOC: FTR, FTT	1

(1) ITEM NO.	(2) SMR CODE	(3) NSN	(4) CAGEC	(5) PART NUMBER	(6) DESCRIPTION AND USABLE ON CODE (UOC)	(7) QTY
15	PAOZZ	5411-01-529-9258	1NSG3	16500334-001	.. LOCK, SGT GREENLY BAR OD UOC: FTR	1
	PAOZZ	5411-01-529-9259	1NSG3	16500334-002	.. LOCK, SGT GREENLY BAR DS UOC: FTT	1
16	PAOOO	5411-01-529-9260	1NSG3	16503650-001	..DRAWER ASSY 4" OD UOC: FTR	1
	PAOOO	5411-01-529-9261	1NSG3	16503650-002	..DRAWER ASSY 4" DS UOC: FTT	1
17	PAOZZ	5411-01-529-9273	1NSG3	16503612	...DIVIDERS 4" MEDIUM	9
18	PAOZZ	5411-01-529-9262	1NSG3	16503611	...DIVIDERS 4" SMALL	27
19	XDOZZ		1NSG3	15121054	...SCREW FLANGE HEAD UOC: FTR, FTT	
20	XDOZZ		1NSG3	16500312	...TABS, LOCKOUT	2
21	XDOZZ		3HZN5	ASH656972N	...SLAM LATCH UOC: FTR, FTT	1
22	XDOZZ		1NSG3	16503654-001	...LID, DRAWER OD UOC: FTR	1
	XDOZZ		1NSG3	16503654-002	...LID, DRAWER DS UOC: FTT	1
23	PAOOO	5411-01-530-1035	1NSG3	16502400-001	..DRAWER ASSY 6" OD UOC: FTR	3
	PAOOO	5411-01-530-4608	1NSG3	16502400-002	..DRAWER ASSY 6" DS UOC: FTT	3
24	PAOZZ	5411-01-530-1001	1NSG3	15520603	...DIVIDERS 6" MEDIUM	6
25	PAOZZ	5411-01-529-9263	1NSG3	15520604	...DIVIDERS 6" SMALL	18
26	XDOZZ		3HZN5	ASH656972N	...SLAM LATCH UOC: FTR, FTT	1
27	XDOZZ		1NSG3	15121054	... SCREW FLANGE HEAD UOC: FTR, FTT	
28	XDOZZ		1NSG3	16500312	...TABS, LOCKOUT	2
29	PAOOO	5411-01-529-9264	1NSG3	16502300-001	..DRAWER ASSY 8" OD UOC: FTR	1
	PAOOO	5411-01-529-9265	1NSG3	16502300-002	..DRAWER ASSY 8" DS UOC: FTT	1
30	PAOOO	5411-01-529-9266	1NSG3	15520804	...DIVIDERS 8" SMALL	

(1)	(2)	(3)	(4)	(5)	(6)	(7)
ITEM NO.	SMR CODE	NSN	CAGEC	PART NUMBER	DESCRIPTION AND USABLE ON CODE (UOC)	QTY
31	XDOZZ		3HZN5	ASH656972N	...SLAM LATCH UOC: FTR, FTT	1
32	XDOZZ		1NSG3	16500312	...TABS, LOCKOUT	2
33	XDOZZ		1NSG3	15121054	...SCREW FLANGE HEAD UOC: FTR, FTT	
34	PAOZZ	5411-01-530-1004	1NSG3	15522003-001	..DUST COVER OD UOC: FTR	1
	PAOZZ	5411-01-529-9267	1NSG3	15522003-002	..DUST COVER DS UOC: FTT	1
END OF FIGURE						

OPERATOR'S, UNIT AND DIRECT SUPPORT MAINTENANCE

AUTHORIZED STOCKAGE LIST MOBILITY SYSTEM (ASLMS)

MODEL NUMBER FPU-8/12 PARTS (OD) P/N 15005002-001

NSN 5411-01-523-2071

MODEL NUMBER FPU-8/12 PARTS (DS) P/N 15005002-002

NSN 5411-01-523-2072

MODEL NUMBER FPU-8/12 BULK (OD) P/N 15005001-001

NSN 5411-01-523-2073

MODEL NUMBER FPU-8/12 BULK (DS) P/N 15005001-002

NSN 5411-01-523-2074

VERTICAL RACK FRAME

NOTE: DOORS OPEN FOR CLARITY

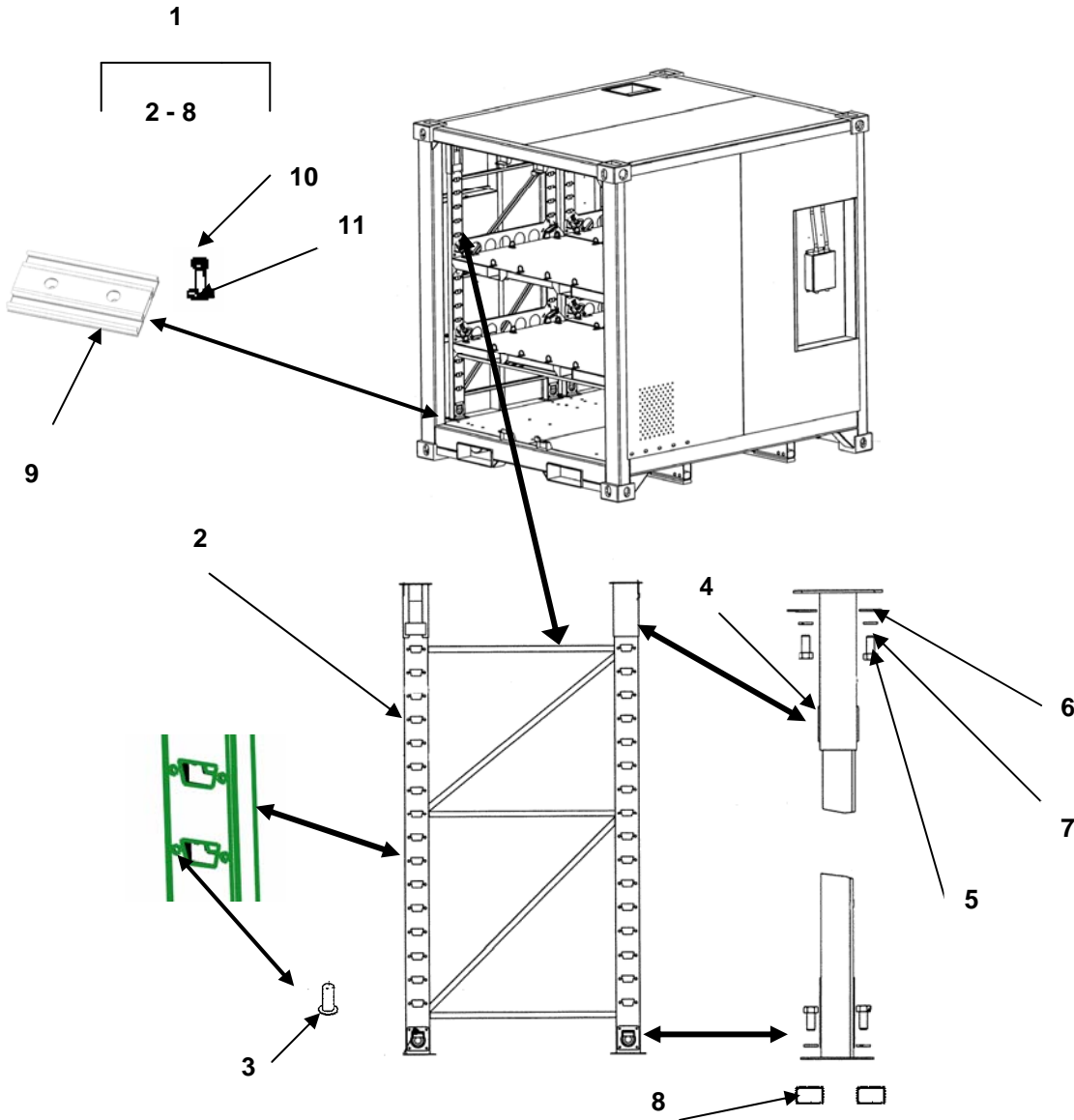

Figure 16. Vertical Rack Frame

(1) ITEM NO.	(2) SMR CODE	(3) NSN	(4) CAGEC	(5) PART NUMBER	(6) DESCRIPTION AND USABLE ON CODE (UOC)	(7) QTY
					GROUP 020401 VERTICAL RACK FRAME FIG. 16 VERTICAL RACK FRAME	
1	PAOFF	5411-01-530-1015	INSG3	16500250-001	VERTICAL RACK ASSY	8
	PAOFF	5411-01-530-1019	INSG3	16500250-002	VERTICAL RACK ASSY	8
2	XDFFF		1NSG3	15700401-001	VERTICAL RACK	1
	XDFFF		1NSG3	15700401-002	VERTICAL RACK	1
3	XDFZZ		OVNM9	CAH2-3118-150	..NUT, RIVET 5/16" 18	64
4	PAFZZ	5411-01-530-1020	1NSG3	16500252-001	.ATTACHMENT UPPER	2
	PAFZZ	5411-01-530-1021	1NSG3	16500252-002	.ATTACHMENT UPPER	2
5	XDFZZ		1RDQ0	2M014	.BOLT, HEXHD ½ X 1 13	12
6	XDFZZ		1RDQ0	4P533	.WASHER, FLAT, 1/2	
7	XDFZZ		1RDQ0	2V106	.WASHER LOCK 1/2	12
8	XDFZZ		07BY4	3259T19	.UNI STRUT NUT	4
9	PAFZZ	5411-01-529-8375	1NSG3	16500451-001	PLATE, ADAPTER OD UOC: FTS	8
	PAFZZ	5411-01-529-9249	1NSG3	16500451-002	PLATE, ADAPTER DS UOC: FTU	8
10	XDFZZ		1RDQ0	4P286	.BOLT, HEXHD ½ -13 X 1 ½	2
11	XDFZZ		1RDQ0	2V106	.WASHER, LOCK ½ GR8	2
END OF FIGURE						

OPERATOR'S, UNIT AND DIRECT SUPPORT MAINTENANCE

AUTHORIZED STOCKAGE LIST MOBILITY SYSTEM (ASLMS)

MODEL NUMBER FPU-8/12 PARTS (OD) P/N 15005002-001

NSN 5411-01-523-2071

MODEL NUMBER FPU-8/12 PARTS (DS) P/N 15005002-002

NSN 5411-01-523-2072

MODEL NUMBER FPU-8/12 BULK (OD) P/N 15005001-001

NSN 5411-01-523-2073

MODEL NUMBER FPU-8/12 BULK (DS) P/N 15005001-002

NSN 5411-01-523-2074

PALLET/CARGO NETS

NOTE: DOORS OPEN FOR CLARITY

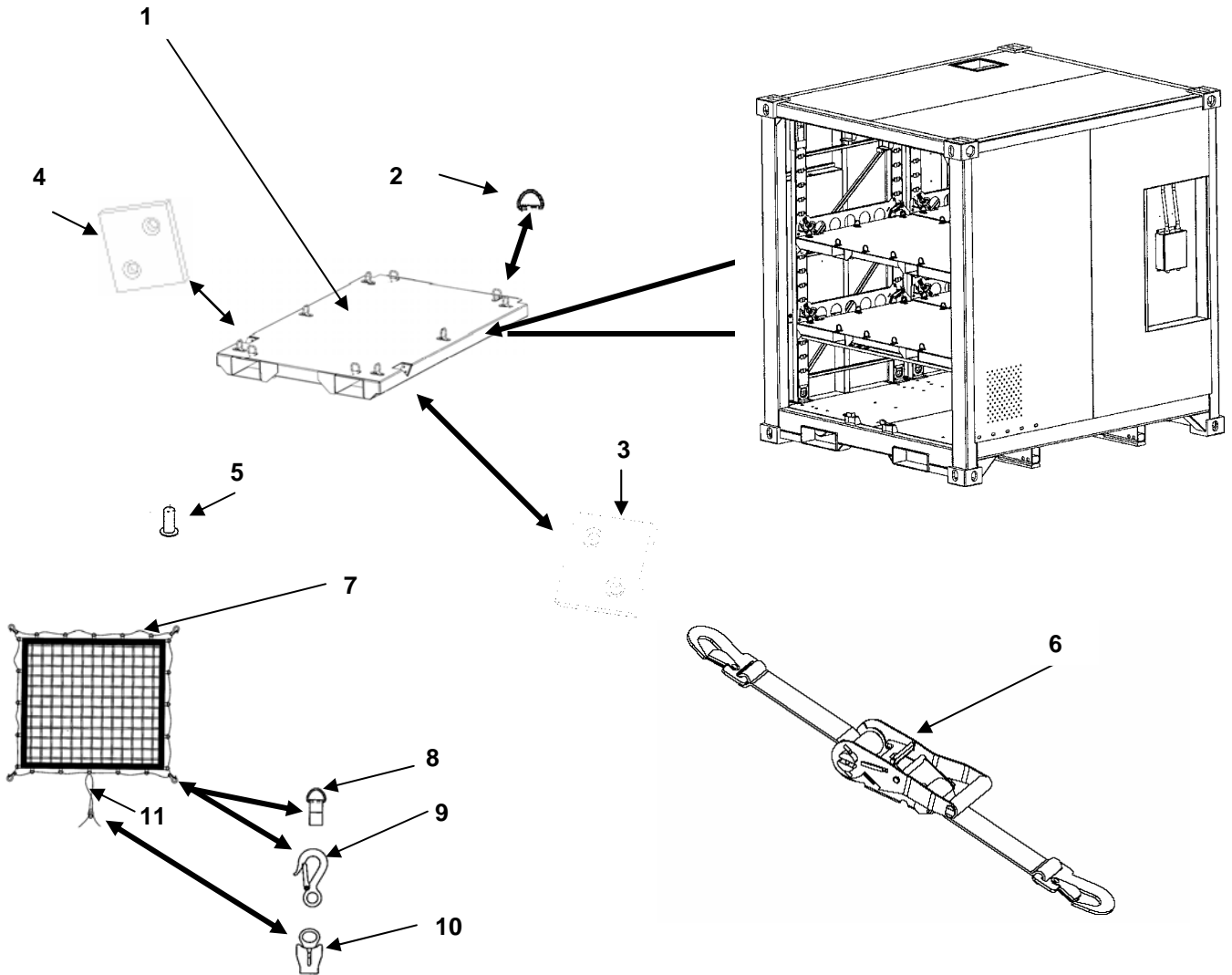

Figure 17. Pallet/Cargo Nets

(1)	(2)	(3)	(4)	(5)	(6)	(7)
ITEM NO.	SMR CODE	NSN	CAGEC	PART NUMBER	DESCRIPTION AND USABLE ON CODE (UOC)	QTY
					GROUP 020402 PALLET/CARGO NETS	
					FIG. 17 PALLET/CARGO NETS	
1	PAOFF	5411-01-529-9265	1NSG3	16506750-001	PALLET, MEDIUM CARGO UOC: FTS	4
	PAOFF	5411-01-529-9269	1NSG3	16506750-002	PALLET, MEDIUM CARGO UOC: FTU	4
2	XDFZZ		7B735	700 ZN	.D RING WELDED	14
3	PAFZZ	5411-01-529-9216	1NSG3	16503544	.PAD, LOCK ROD RT UOC: FTS, FTU	1
4	PAFZZ	5411-01-529-9213	1NSG3	16503549	.PAD, LOCK ROD LFT UOC: FTS, FTU	1
5	XDFZZ		1RDQ0	4Y114	.RIVET UOC: FTS, FTU	
6	XDOZZ		1NSG3	15240152	STRAPS, RATCHET	16
7	PAOZZ	5411-01-529-9270	1NSG3	16501609	NET, CARGO FLOOR UOC: FTS, FTU	2
8	XDOZZ		07BY4	3648T73	.D RING, 1"	20
9	XDOZZ		75535	1023056	.HOOK, SAFETY SNAP	4
10	XDOZZ		06QB1	586552	.CORD CLOSURE	1
11	MOOZZ		63806	G603CAM-00-000	.CORD, CAMO 1/4	
					END OF FIGURE	

OPERATOR'S, UNIT AND DIRECT SUPPORT MAINTENANCE

AUTHORIZED STOCKAGE LIST MOBILITY SYSTEM (ASLMS)

MODEL NUMBER FPU-8/12 PARTS (OD) P/N 15005002-001

NSN 5411-01-523-2071

MODEL NUMBER FPU-8/12 PARTS (DS) P/N 15005002-002

NSN 5411-01-523-2072

MODEL NUMBER FPU-8/12 BULK (OD) P/N 15005001-001

NSN 5411-01-523-2073

MODEL NUMBER FPU-8/12 BULK (DS) P/N 15005001-002

NSN 5411-01-523-2074

PALLET LEDGE

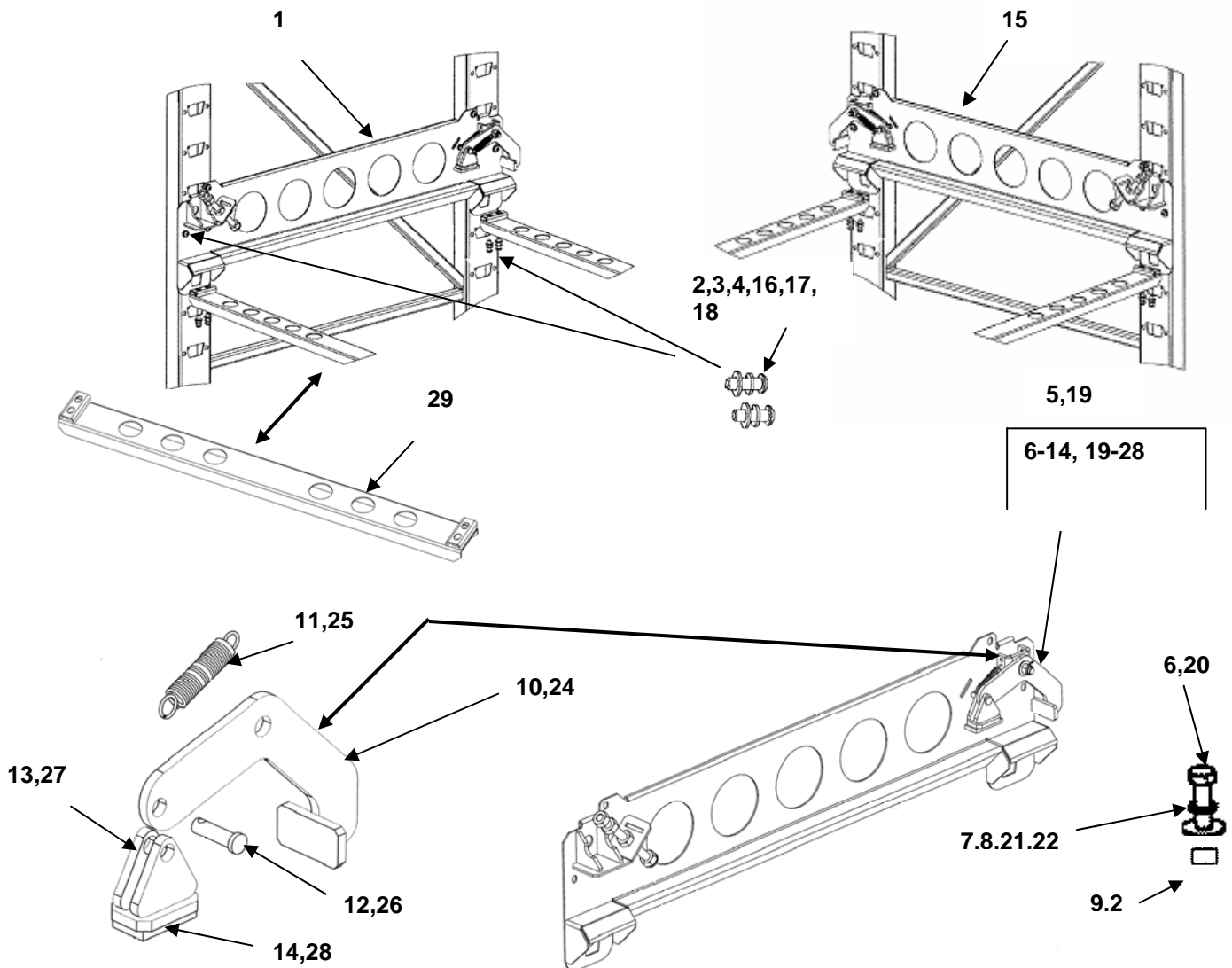

Figure 18. Pallet Ledge

(1)	(2)	(3)	(4)	(5)	(6)	(7)
ITEM NO.	SMR CODE	NSN	CAGEC	PART NUMBER	DESCRIPTION AND USABLE ON CODE (UOC)	QTY
					GROUP 020403 PALLET LEDGE FIG. 18 PALLET LEDGE	
1	PAOOO	5411-01-529-9218	INSG3	16503559-001	PALLET LEDGE LFT OD UOC: FTS	4
	PAOOO	5411-01-529-9224	INSG3	16503559-002	PALLET LEDGE LFT DS UOC: FTU	4
2	XDOZZ		1RDQ0	3H424	. BOLT, ALLEN 5/16" x1"	8
3	XDOZZ		1RDQ0	4P530	. WASHER, LOCK 5/16"	8
4	XDOZZ		1RDQ0	4P503	. WASHER , FLAT 5/16"	8
5	PAOZZ	5411-01-529-9229	1NSG3	16503561-001	.LOCKS, CAM ASSY OD UOC: FTS	1
	PAOZZ	5411-01-529-9230	1NSG3	16503561-002	.LOCKS, CAM ASSY DS UOC: FTS	1
6	XDOZZ		1RDQ0	2X672	..BOLT, SHOULDER	1
7	XDOZZ		1RDQ0	4P533	..WASHER, FLAT, 1/2	1
8	XDOZZ		07BY4	90295A170	..WASHER, NYLON, 1/2	1
9	XDOZZ		1RDQ0	4P434	..NUT LOCK, 3/8-16	1
10	XDOZZ		1NSG3	16503563-001	..LOCK CAM ARM OD UOC: FTS	1
	XDOZZ		1NSG3	16503563-002	..LOCK CAM ARM DS UOC: FTU	1
11	XDOZZ		56048	E0500-069-2750	..SPRING EXTENSION	1
12	XDOZZ		07BY4	92390A271	..PIN, CLEVIS 3/8 X 1 1/4	1
13	XDOZZ		1NSG3	16503562-001	..CAM FOOT UOC: FTS	1
	XDOZZ		1NSG3	16503562-002	..CAM FOOT UOC: FTU	1
14	XDOZZ		1NSG3	16503521	...PAD RUBBER	1
15	PAOOO	5411-01-529-9221	INSG3	16503560-001	PALLET LEDGE RHT OD UOC: FTS	4
	PAOOO	5411-01-529-9227	INSG3	16503560-002	PALLET LEDGE RHT DS UOC: FTU	4
16	XDOZZ		1RDQ0	3H424	. BOLT, ALLEN 5/16" x1"	8
17	XDOZZ		1RDQ0	4P530	. WASHER, LOCK 5/16"	8

(1)	(2)	(3)	(4)	(5)	(6)	(7)
ITEM NO.	SMR CODE	NSN	CAGEC	PART NUMBER	DESCRIPTION AND USABLE ON CODE (UOC)	QTY
18	XDOZZ		1RDQ0	4P503	. WASHER, FLAT 5/16"	8
19	PAOZZ	5411-01-529-9229	1NSG3	16503561-001	.LOCKS, CAM ASSY OD UOC: FTS	1
	PAOZZ	5411-01-529-9230	1NSG3	16503561-002	.LOCKS, CAM ASSY DS UOC: FTS	1
20	XDOZZ		1RDQ0	2X672	..BOLT, SHOULDER	1
21	XDOZZ		1RDQ0	4P533	..WASHER, FLAT, 1/2	1
22	XDOZZ		07BY4	90295A170	..WASHER, NYLON, 1/2	1
23	XDOZZ		1RDQ0	4P434	..NUT LOCK, 3/8-16	1
24	XDOZZ		1NSG3	16503563-001	..LOCK CAM ARM OD UOC: FTS	1
	XDOZZ		1NSG3	16503563-002	..LOCK CAM ARM DS UOC: FTU	1
25	XDOZZ		56048	E0500-069-2750	..SPRING EXTENSION	1
26	XDOZZ		07BY4	92390A271	..PIN, CLEVIS 3/8 X 1 1/4	1
27	XDOZZ		1NSG3	16503562-001	..CAM FOOT UOC: FTS	1
	XDOZZ		1NSG3	16503562-002	..CAM FOOT UOC: FTU	1
28	XDOZZ		1NSG3	16503521	...PAD RUBBER	1
29	PAOZZ	5411-01-529-9271	1NSG3	16503754-001	HORIZ STABILIZER, 67", OD	8
	PAOZZ	5411-01-529-9272	1NSG3	16503754-002	HORIZ STABILIZER, 67", DS	8

END OF FIGURE

**OPERATOR'S, UNIT AND DIRECT SUPPORT MAINTENANCE
AUTHORIZED STOCKAGE LIST MOBILITY SYSTEM (ASLMS)**

- MODEL NUMBER FPU-8/12 PARTS (OD) P/N 15005002-001
NSN 5411-01-523-2071**
- MODEL NUMBER FPU-8/12 PARTS (DS) P/N 15005002-002
NSN 5411-01-523-2072**
- MODEL NUMBER FPU-8/12 BULK (OD) P/N 15005001-001
NSN 5411-01-523-2073**
- MODEL NUMBER FPU-8/12 BULK (DS) P/N 15005001-002
NSN 5411-01-523-2074**

FOLDING STEPS

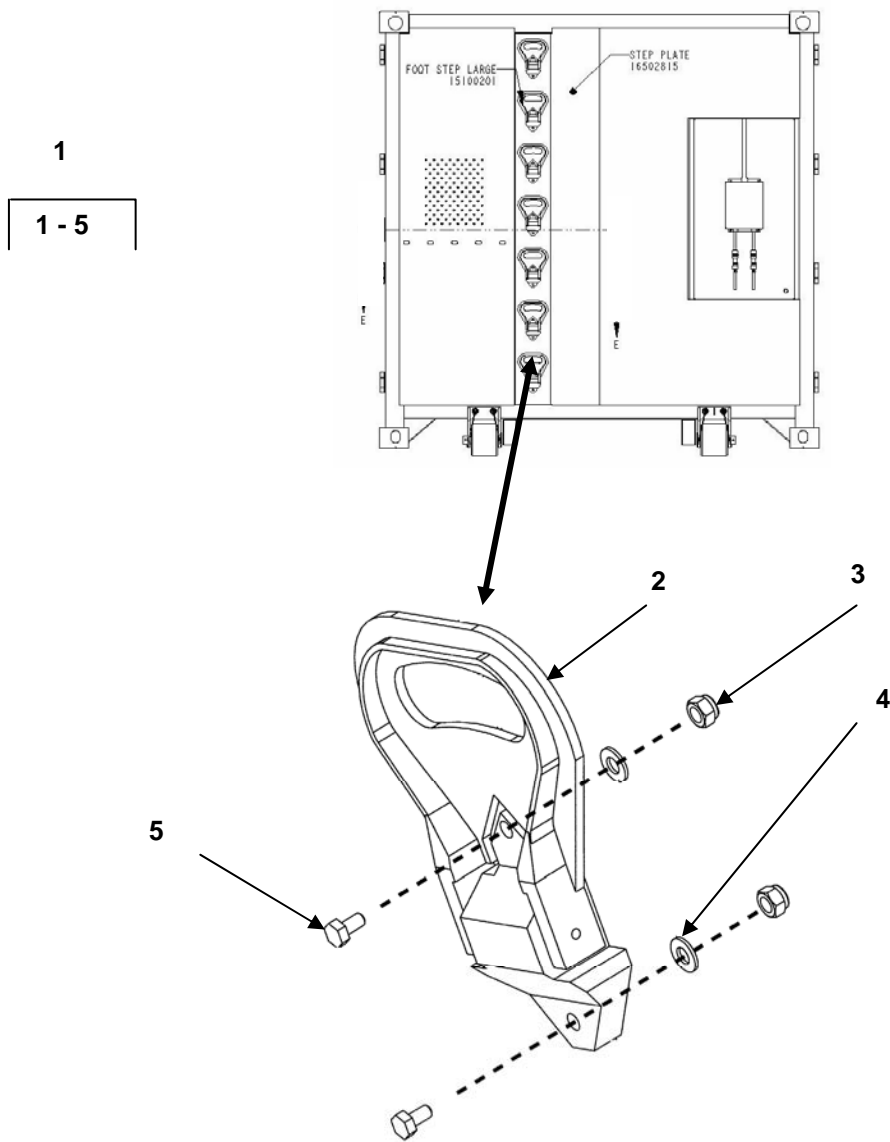

Figure 19. Folding Steps

(1) ITEM NO.	(2) SMR CODE	(3) NSN	(4) CAGEC	(5) PART NUMBER	(6) DESCRIPTION AND USABLE ON CODE (UOC)	(7) QTY
					GROUP 03 FOLDING STEPS FIG. 19 FOLDING STEPS	
1	PAOOO	5411-01-530-1007	1NSG3	15100201-001	STEP ASSY.W HDWR OD UOC: FTR, FTS	7
	PAOOO	5411-01-530-1012	1NSG3	15100201-002	STEP ASSY.W HDWR DS UOC: FTT, FTU	7
2	PAOZZ	5410-00-984-5065	19220	1-585809	.STEP, RECESSED, FOLDI	1
3	XDOZZ		1RDQ0	4P433	.NUT LOCK 5/16	2
4	XDOZZ		07BY4	94709A318	.WASHER, FLAT SEALED 5/16	2
5	XDOZZ		1RDQ0	4P263	. BOLT, HEX 5/16-18 x1 1/4"	2
END OF FIGURE						

OPERATOR'S, UNIT AND DIRECT SUPPORT MAINTENANCE

AUTHORIZED STOCKAGE LIST MOBILITY SYSTEM (ASLMS)

MODEL NUMBER FPU-8/12 PARTS (OD) P/N 15005002-001

NSN 5411-01-523-2071

MODEL NUMBER FPU-8/12 PARTS (DS) P/N 15005002-002

NSN 5411-01-523-2072

MODEL NUMBER FPU-8/12 BULK (OD) P/N 15005001-001

NSN 5411-01-523-2073

MODEL NUMBER FPU-8/12 BULK (DS) P/N 15005001-002

NSN 5411-01-523-2074

CONNECTOR KIT

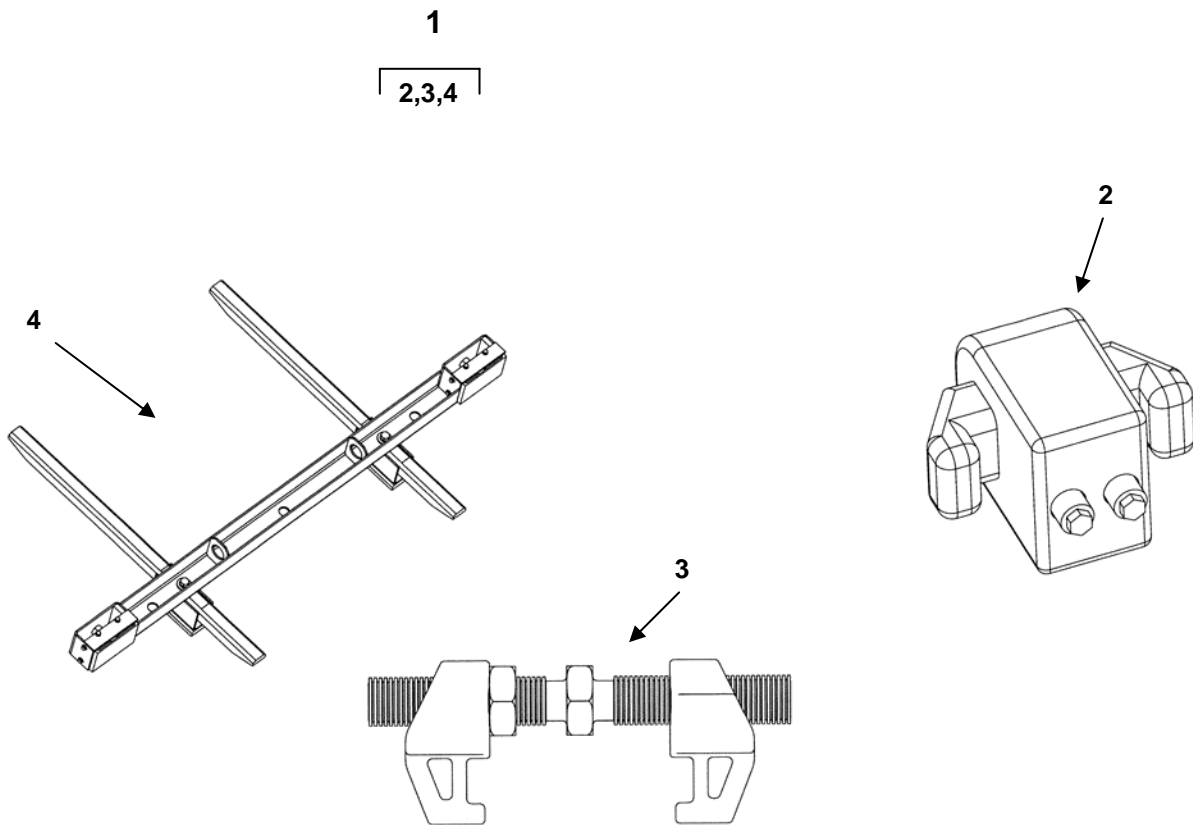

Figure 20. Connector Kit

(1)	(2)	(3)	(4)	(5)	(6)	(7)
ITEM NO.	SMR CODE	NSN	CAGEC	PART NUMBER	DESCRIPTION AND USABLE ON CODE (UOC)	QTY
					GROUP 04 CONNECTOR KIT FIG. 20 CONNECTOR KIT	
1	XDOOO		1NSG3	15310101-001	CONNECTOR KIT OD UOC: FTR, FTS	1
	XDOOO		1NSG3	15310101-002	CONNECTOR KIT OD UOC: FTT, FTR	1
2	PAOZZ	5410-01-363-7086	65059	12900BA-1PZ	.INTERCONNECTOR HORI	4
3	PAOZZ	5411-01-530-1892	1NSG3	15312220	.BRIDGE LOCK	2
4	PAOOO	5411-01-529-9274	1NSG3	16503454-001	.LOAD RAIL CONNECTOR ASSY OD UOC: FTR, FTS	1
	PAOOO	5411-01-529-9275	1NSG3	16503454-002	.LOAD RAIL CONNECTOR ASSY DS UOC: FTT, FTU	1
END OF FIGURE						

OPERATOR'S, UNIT AND DIRECT SUPPORT MAINTENANCE

AUTHORIZED STOCKAGE LIST MOBILITY SYSTEM (ASLMS)

MODEL NUMBER FPU-8/12 PARTS (OD) P/N 15005002-001

NSN 5411-01-523-2071

MODEL NUMBER FPU-8/12 PARTS (DS) P/N 15005002-002

NSN 5411-01-523-2072

MODEL NUMBER FPU-8/12 BULK (OD) P/N 15005001-001

NSN 5411-01-523-2073

MODEL NUMBER FPU-8/12 BULK (DS) P/N 15005001-002

NSN 5411-01-523-2074

LOAD RAIL CONNECTOR ASSEMBLY

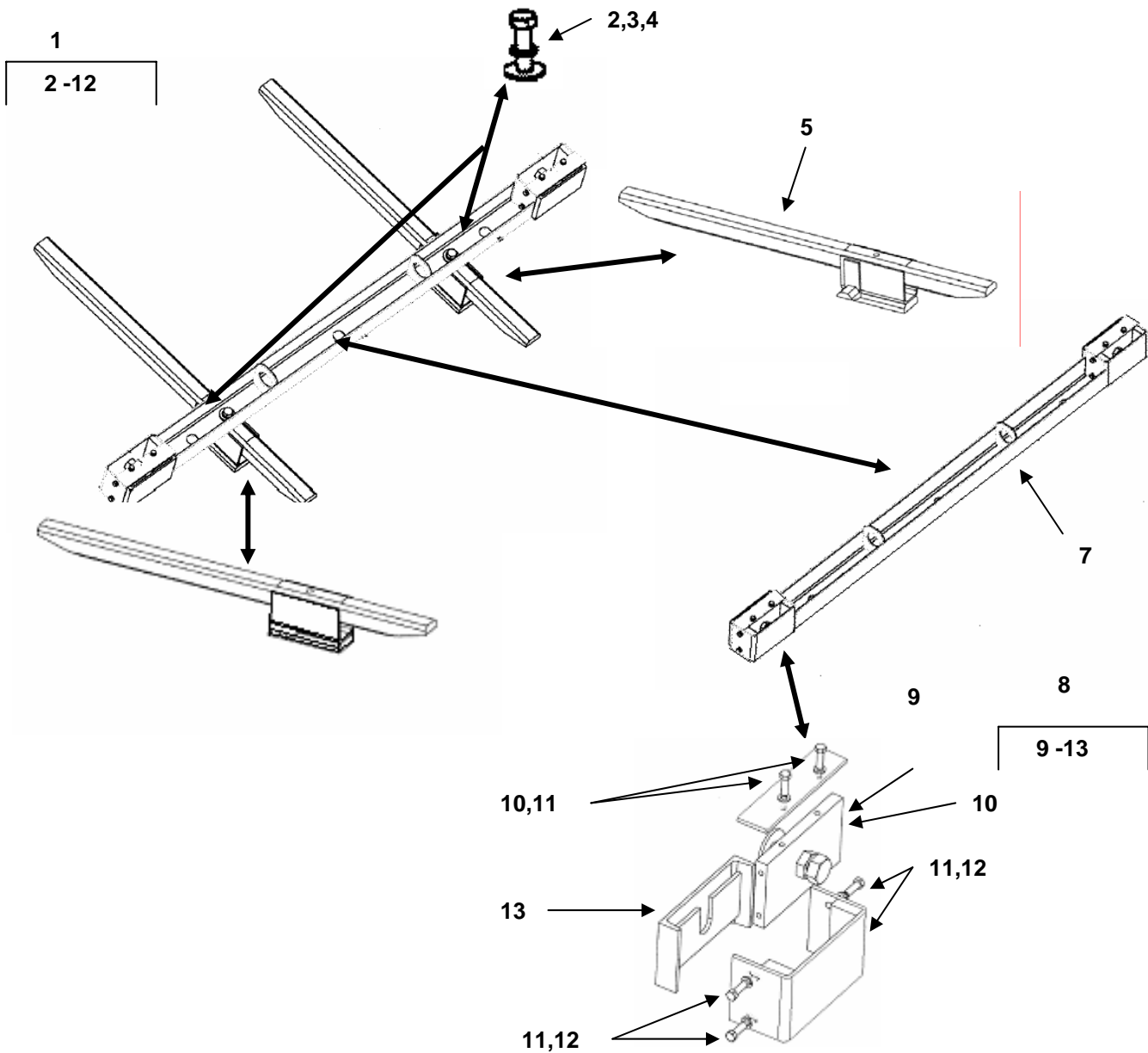

Fig. 21. Load Rail Connector Assembly

(1)	(2)	(3)	(4)	(5)	(6)	(7)
ITEM NO.	SMR CODE	NSN	CAGEC	PART NUMBER	DESCRIPTION AND USABLE ON CODE (UOC)	QTY
					GROUP 0401 LOAD RAIL CONNECTOR ASSEMBLY FIG. 21 LOAD RAIL CONNECTOR ASSEMBLY	
1	PAOOO	5411-01-529-9274	1NSG3	16503454-001	CONNECTOR, LOAD RAIL ASSY, OD UOC: FTR, FTS	1
	PAOOO	5411-01-529-9275	1NSG3	16503454-002	CONNECTOR, LOAD RAIL ASSY DS UOC: FTT, FTU	1
2	XDOZZ		07BY4	92620A839	.BOLT, 3/4"-10 X 1 1/2" GRD 8	2
3	XDOZZ		1RDQ0	2V112	.WASHER, LOCK 3/4" HVY	2
4	XDOZZ		1RDQ0	4P535	.WASHER, FLAT 3/4" HVY	2
5	XDOZZ		1NSG3	16502853	. CONNECTOR, RAIL CB SIDE	1
6	XDOZZ		1NSG3	16502854	. CONNECTOR, RAIL SS SIDE	1
7	XDOOO		1NSG3	16503457-001	. STABILIZER, TRANSVERSAL, OD UOC: FTR, FTS	1
	XDOOO		1NSG3	16503457-002	.STABILIZER TRANSVERSAL, DS UOC: FTT, FTU	1
8	XDOOO		1NSG3	16503455-001	.. BLOCK ASSY, TENSION OD UOC: FTR, FTS	2
	XDOOO		1NSG3	16503455-002	.. BLOCK ASSY, TENSION DS UOC: FTT, FTU	2
9	XDOZZ		1NSG3	16502844-001	... CAP, TENSION BLOCK, OD UOC: FTR, FTS	1
	XDOZZ		1NSG3	16502844-002	... CAP, TENSION BLOCK, DS UOC: FTT, FTU	1
10	XDOZZ		1NSG3	16503458-001	...BOLT PLATE, TENSION BLOCK, OD UOC: FTR, FTS	1
	XDOZZ		1NSG3	16503458-002	... BOLT PLATE, TENSION BLOCK, DS UOC: FTT, FTU	1
11	XDOZZ		1RDQ0	4P270	...BOLT, 3/8-16"X1" GRD 8	6
12	XDOZZ		1RDQ0	2V102	...WASHER, LOCK, HVY	
13	XDOZZ		1NSG3	16503459-001	... PRESSURE PLATE, TENSION, OD UOC: FTR, FTS	1
	XDOZZ		1NSG3	16503459-002	...PRESSURE PLATE, TENSION, DS UOC: FTT, FTU	1
END OF FIGURE						

OPERATOR'S, UNIT AND DIRECT SUPPORT MAINTENANCE

AUTHORIZED STOCKAGE LIST MOBILITY SYSTEM (ASLMS)

MODEL NUMBER FPU-8/12 PARTS (OD) P/N 15005002-001

NSN 5411-01-523-2071

MODEL NUMBER FPU-8/12 PARTS (DS) P/N 15005002-002

NSN 5411-01-523-2072

MODEL NUMBER FPU-8/12 BULK (OD) P/N 15005001-001

NSN 5411-01-523-2073

MODEL NUMBER FPU-8/12 BULK (DS) P/N 15005001-002

NSN 5411-01-523-2074

FORK POCKET PLUG ASSEMBLY

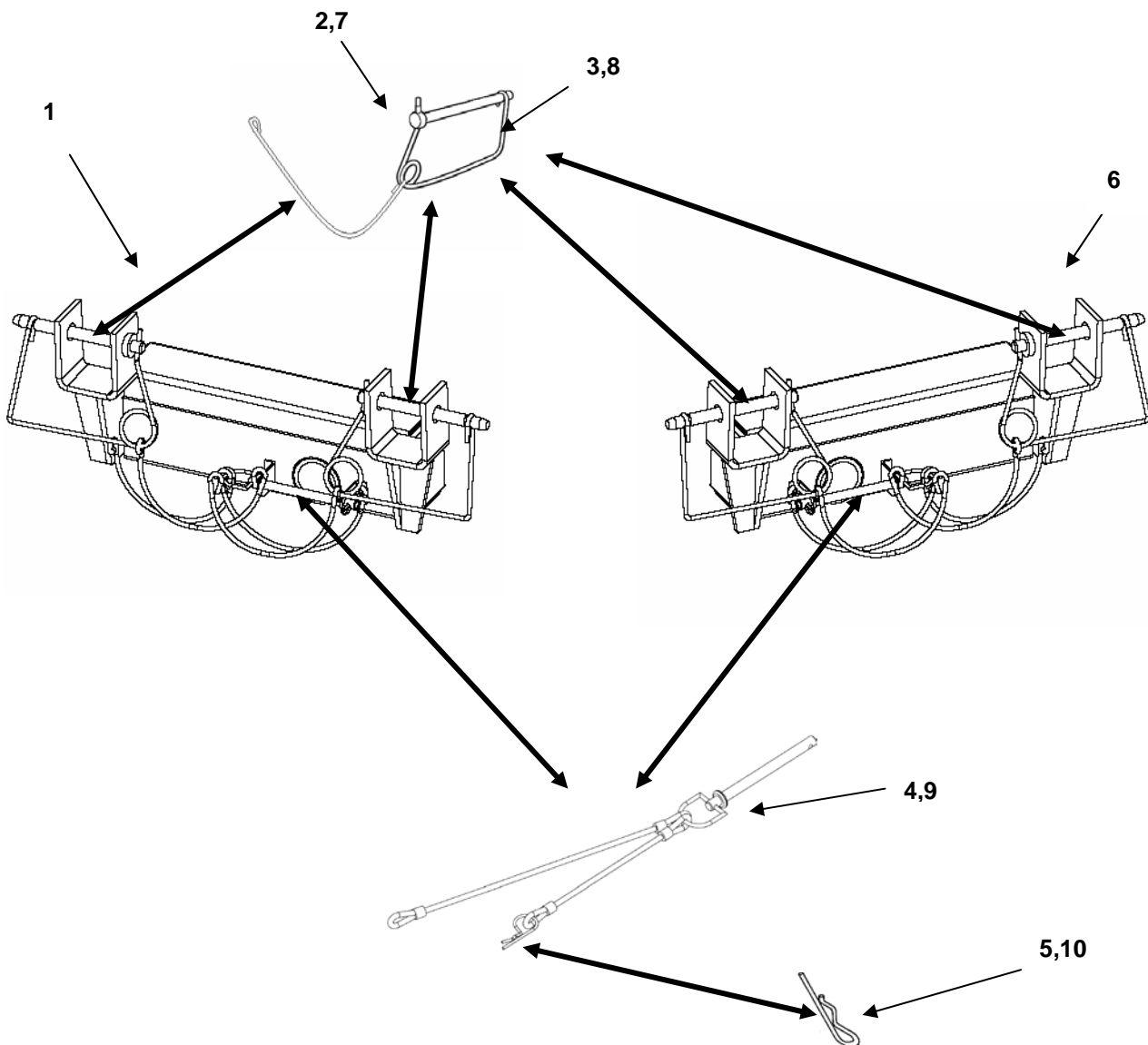

Figure 22. Fork Pocket Plug Assembly

(1)	(2)	(3)	(4)	(5)	(6)	(7)
ITEM NO.	SMR CODE	NSN	CAGEC	PART NUMBER	DESCRIPTION AND USABLE ON CODE (UOC)	QTY
					GROUP 05 FORK POCKET PLUG ASSEMBLY FIG. 22 FORK POCKET PLUG ASSEMBLY	
1	PAOOO	5411-01-530-1022	1NSG3	16501051-001	ADAPTER, TRAILER ROAD UOC: FTR FTS	1
	PAOOO	5411-01-529-9254	1NSG3	16501051-002	ADAPTER, TRAILER ROAD UOC: FTT, FTU	1
2	PAOOO	5411-01-530-9280	1NSG3	16501053	.PIN, CONNECTING	2
3	PAOZZ	5315-01-483-8825	2W507	971431650	..PIN QUICK RELEASE	2
4	PAOOO	5411-01-530-1030	1NSG3	15120662	.PIN WITH LANYARDS	1
5	XDOZZ		1RDQ0	98335A065	..PIN, HAIRPIN COTTER	1
6	PAOOO	5411-01-529-9282	1NSG3	16501050-001	ADAPTER, TRAILER CURB UOC: FTR, FTS	1
	PAOOO	5411-01-530-1018	1NSG3	16501050-002	ADAPTER, TRAILER CURB UOC: FTT, FTU	1
7	PAOOO	5411-01-529-9280	1NSG3	16501053	.PIN, CONNECTING	2
8	PAOZZ	5315-01-483-8825	2W507	971431650	..PIN QUICK RELEASE	2
9	PAOOO	5411-01-530-1030	1NSG3	15120662	.PIN WITH LANYARDS	2
10	XDOZZ		1RDQ0	98335A065	..PIN, HAIRPIN COTTER	1
END OF FIGURE						

OPERATOR'S, UNIT AND DIRECT SUPPORT MAINTENANCE

AUTHORIZED STOCKAGE LIST MOBILITY SYSTEM (ASLMS)

MODEL NUMBER FPU-8/12 PARTS (OD) P/N 15005002-001

NSN 5411-01-523-2071

MODEL NUMBER FPU-8/12 PARTS (DS) P/N 15005002-002

NSN 5411-01-523-2072

MODEL NUMBER FPU-8/12 BULK (OD) P/N 15005001-001

NSN 5411-01-523-2073

MODEL NUMBER FPU-8/12 BULK (DS) P/N 15005001-002

NSN 5411-01-523-2074

DISTRIBUTION BOXES

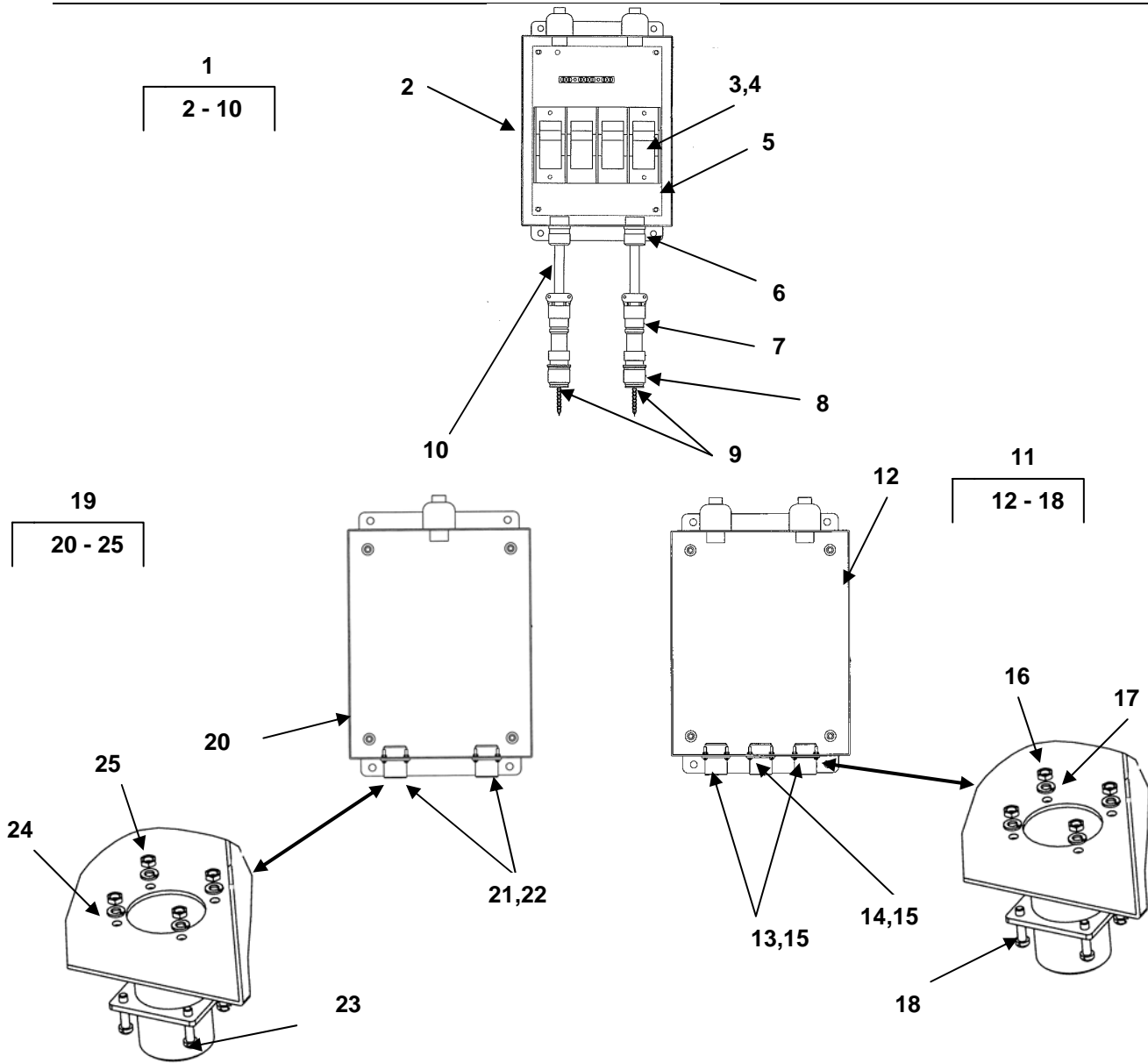

Figure 23. Distribution Boxes

(1)	(2)	(3)	(4)	(5)	(6)	(7)
ITEM NO.	SMR CODE	NSN	CAGEC	PART NUMBER	DESCRIPTION AND USABLE ON CODE (UOC)	QTY
					GROUP 0601 DISTRIBUTION BOXES FIG. 23 DISTRIBUTION BOXES	
1	PAFFF	5411-01-529-9279	1NSG3	16502553-001	DISTRIBUTION BOX A UOC: FTR, FTS	1
	PAFFF	5411-01-529-9283	1NSG3	16502553-002	DISTRIBUTION BOX A UOC: FTT.FTU	1
2	XDFZZ		1NSG3	16502505-001	.BOX ELEC A OD	1
	XDFZZ		1NSG3	16502505-002	.BOX ELEC A DS	1
3	XDFZZ		1NSG3	15312438	.BLOCK DIST	4
4	XDFZZ		1NSG3	15312439-001	.END COVER	1
	XDFZZ		1NSG3	15312439-002	.END COVER	1
5	XDFZZ		1NSG3	16502504	.BACKING PLATE	1
6	XDFZZ		1RDQ0	5D733	.STRAIN CONDUIT CAP	1
7	PAFZZ	5935-01-181-1672	81349	MS85049/11-118W	.CLAMP, CABLE	1
8	PAFZZ	5935-01-026-2217	96906	MS3456W16-10P	.PLUG, CABLE	1
9	PAFZZ	5935-01-189-3220	96906	MS25042-16DA	.COVER, ELECT CONNECT	1
10	MFFZZ		1RDQ0	5W578	.CABLE, SEOW 12/3	2
11	PAFFF	5411-01-529-9285	1NSG3	16502554-001	DISTRIBUTION BOX B UOC FTR.FTS	1
	PAFFF	5411-01-530-1893	1NSG3	16502554-002	DISTRIBUTION BOX B UOC FTT.FTU	1
12	XDFZZ		1NSG3	16502506-001	.BOX ELEC B OD	1
	XDFZZ		1NSG3	16502506-002	.BOX ELEC B DS	1
13	PAFZZ	5935-01-160-1788	96906	MS3452W16-10S	.RECEPTICAL A/C	2
14	PAFZZ	5935-01-151-1245	96906	MS3452W16-11S	.RECEPTICAL D/C	1
15	PAFZZ	5935-01-184-7188	96906	MS25043	.RECEPTICAL PROTECTIVE CAP	3
16	XDFZZ		07BY4	90480A006	.NUT # 5 40	4
17	XDFZZ		07BY4	91102A725	.WASHER LOCK #5	4
18	XDFZZ		07BY4	91794A128	.SCREW #5 40 X1/2	4

(1)	(2)	(3)	(4)	(5)	(6)	(7)
ITEM NO.	SMR CODE	NSN	CAGEC	PART NUMBER	DESCRIPTION AND USABLE ON CODE (UOC)	QTY
19	PAFFF	5411-01-530-1023	1NSG3	16502555-001	DISTRIBUTION BOX C UOC: FTR, FTS	1
	PAFFF	5411-01-529-9286	1NSG3	16502555-002	DISTRIBUTION BOX C UOC: FTT, FTU	1
20	XDOZZ		1NSG3	16502507-001	.BOX ELEC C OD	1
	XDOZZ		1NSG3	16502507-002	.BOX ELEC C DS	1
21	PAFZZ	5935-01-160-1788	96906	MS 3452W16-10S	.RECEPTICAL A/C	2
22	PAOZZ	5935-01-184-7188	96906	MS25043	.RECEPTICAL PROTECTIVE CAP	2
23	XDFZZ		07BY4	91794A128	.SCREW #5 40 X1/2	4
24	XDFZZ		07BY4	90480A006	.NUT # 5 40	4
25	XDFZZ		07BY4	91102A725	.WASHER LOCK #5	4
END OF FIGURE						

OPERATOR'S, UNIT AND DIRECT SUPPORT MAINTENANCE

AUTHORIZED STOCKAGE LIST MOBILITY SYSTEM (ASLMS)

MODEL NUMBER FPU-8/12 PARTS (OD) P/N 15005002-001

NSN 5411-01-523-2071

MODEL NUMBER FPU-8/12 PARTS (DS) P/N 15005002-002

NSN 5411-01-523-2072

MODEL NUMBER FPU-8/12 BULK (OD) P/N 15005001-001

NSN 5411-01-523-2073

MODEL NUMBER FPU-8/12 BULK (DS) P/N 15005001-002

NSN 5411-01-523-2074

TRANSFORMER

1
2-7

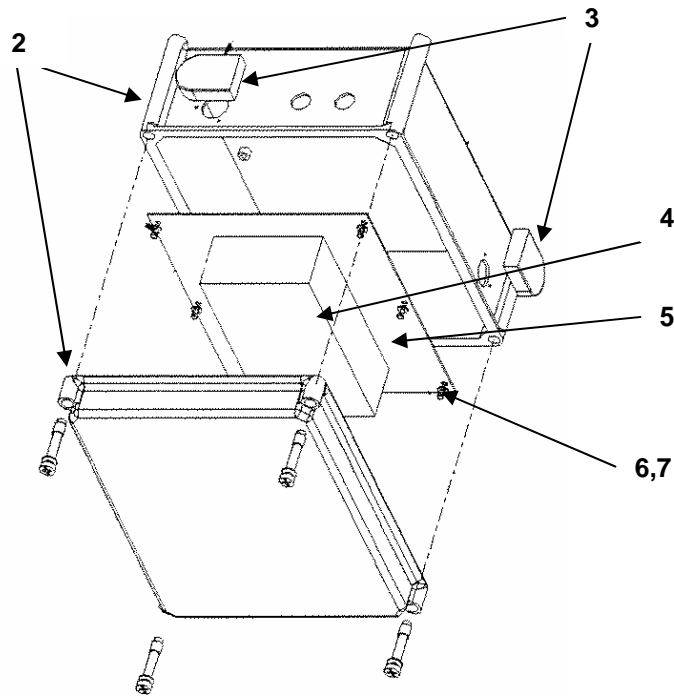

Figure 24. Transformer

(1)	(2)	(3)	(4)	(5)	(6)	(7)
ITEM NO.	SMR CODE	NSN	CAGEC	PART NUMBER	DESCRIPTION AND USABLE ON CODE (UOC)	QTY
1	PAFFF	5411-01-529-9287	1NSG3	16502552-001	GROUP 0602 TRANSFORMER FIG. 24 TRANSFORMER TRANSFORMER ASSY, A/C TO D/C, OD UOC: FTR, FTS	1
	PAFFF	5411-01-529-9290	1NSG3	16502552-002	TRANSFORMER ASSY, A/C TO D/C, DS UOC: FTT, FTU	1
2	XDFZZ		1NSG3	16502502-001	.ENCLOSURE, TRANSFORMER UOC: FTR, FTS	1
	XDFZZ		1NSG3	16502502-002	.ENCLOSURE, TRANSFORMER UOC: FTT, FTU	1
3	XDFZZ		1NSG3	15312433-001	.VENT W/HDWR OD UOC: FTR, FTS	2
	XDFZZ		1NSG3	15312433-002	.VENT W/HDWR DS UOC: FTT, FTU	2
4	PAFZZ	5411-01-530-1895	1NSG3	15220201	.TRANSFORMER 120/12V	1
5	XDFZZ		1NSG3	16502503	.BACKPLATE, TRANSFORM	1
6	XDFZZ		1RDQ0	2V033	.WASHER FLAT #6	6
7	XDFZZ		07BY4	92005A215	.SCREW PAN HD #6	6
END OF FIGURE						

OPERATOR'S, UNIT AND DIRECT SUPPORT MAINTENANCE

AUTHORIZED STOCKAGE LIST MOBILITY SYSTEM (ASLMS)

MODEL NUMBER FPU-8/12 PARTS (OD) P/N 15005002-001
NSN 5411-01-523-2071

MODEL NUMBER FPU-8/12 PARTS (DS) P/N 15005002-002
NSN 5411-01-523-2072

MODEL NUMBER FPU-8/12 BULK (OD) P/N 15005001-001
NSN 5411-01-523-2073

MODEL NUMBER FPU-8/12 BULK (DS) P/N 15005001-002
NSN 5411-01-523-2074

CABLE A/C, 150'

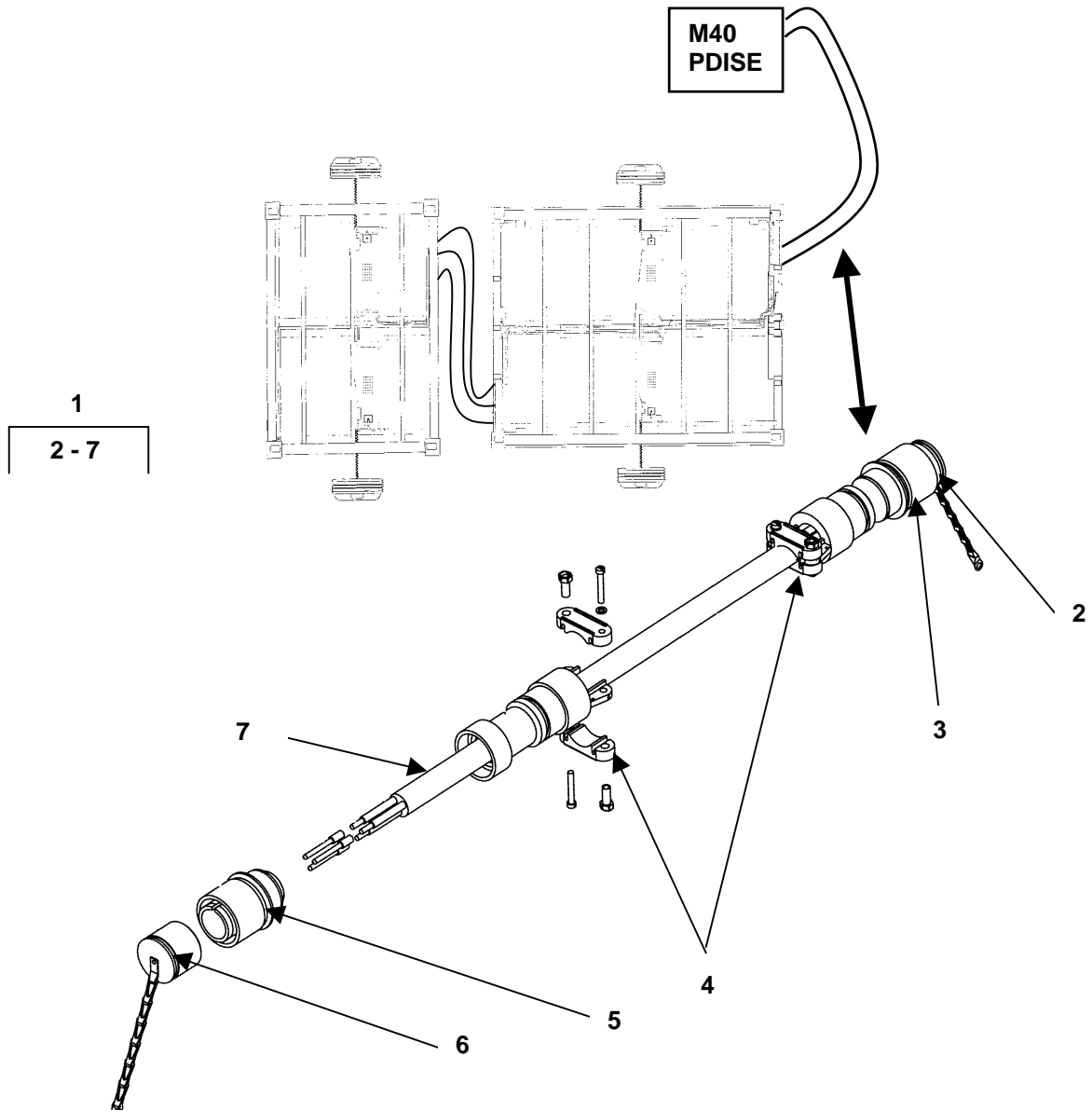

Figure 25. Cable A/C, 150'

(1) ITEM NO.	(2) SMR CODE	(3) NSN	(4) CAGEC	(5) PART NUMBER	(6) DESCRIPTION AND USABLE ON CODE (UOC)	(7) QTY
1	MFOFF		1NSG3	16502558	GROUP 060301 CABLE A/C, 150' FIG. 25 CABLE A/C, 150' CABLE, ASSEMBLY POWER, ELECTRICAL, 150 FT, 120V	2
2	PAFZZ	5935-01-184-7188	96906	MS25043-16DA	.COVER, ELECTRICAL CONNECTOR	1
3	PAFZZ	5935-01-260-9595	96906	MS3451W16-10S	.CONNECTOR, PLUG ELECTRICAL	1
4	PAFZZ	5935-01-181-1672	81343	MS85049/11-118W	.ADAPTER, CABLE CLAMP TO CONNECTOR	2
5	PAFZZ	5935-01-026-2217	96906	MS3456W16-10P	.CONNECTOR, PLUG ELECTRICAL	1
6	PAFZZ	5935-01-189-3220	96906	MS25042-16DA	.COVER, ELECTRICAL CONNECTOR	1
7	MFFZZ		1RDQ0	5W578	.CABLE, POWER ELECTRICAL, 12/3	V
END OF FIGURE						

OPERATOR'S, UNIT AND DIRECT SUPPORT MAINTENANCE

AUTHORIZED STOCKAGE LIST MOBILITY SYSTEM (ASLMS)

MODEL NUMBER FPU-8/12 PARTS (OD) P/N 15005002-001

NSN 5411-01-523-2071

MODEL NUMBER FPU-8/12 PARTS (DS) P/N 15005002-002

NSN 5411-01-523-2072

MODEL NUMBER FPU-8/12 BULK (OD) P/N 15005001-001

NSN 5411-01-523-2073

MODEL NUMBER FPU-8/12 BULK (DS) P/N 15005001-002

NSN 5411-01-523-2074

CABLE A/C, 9'

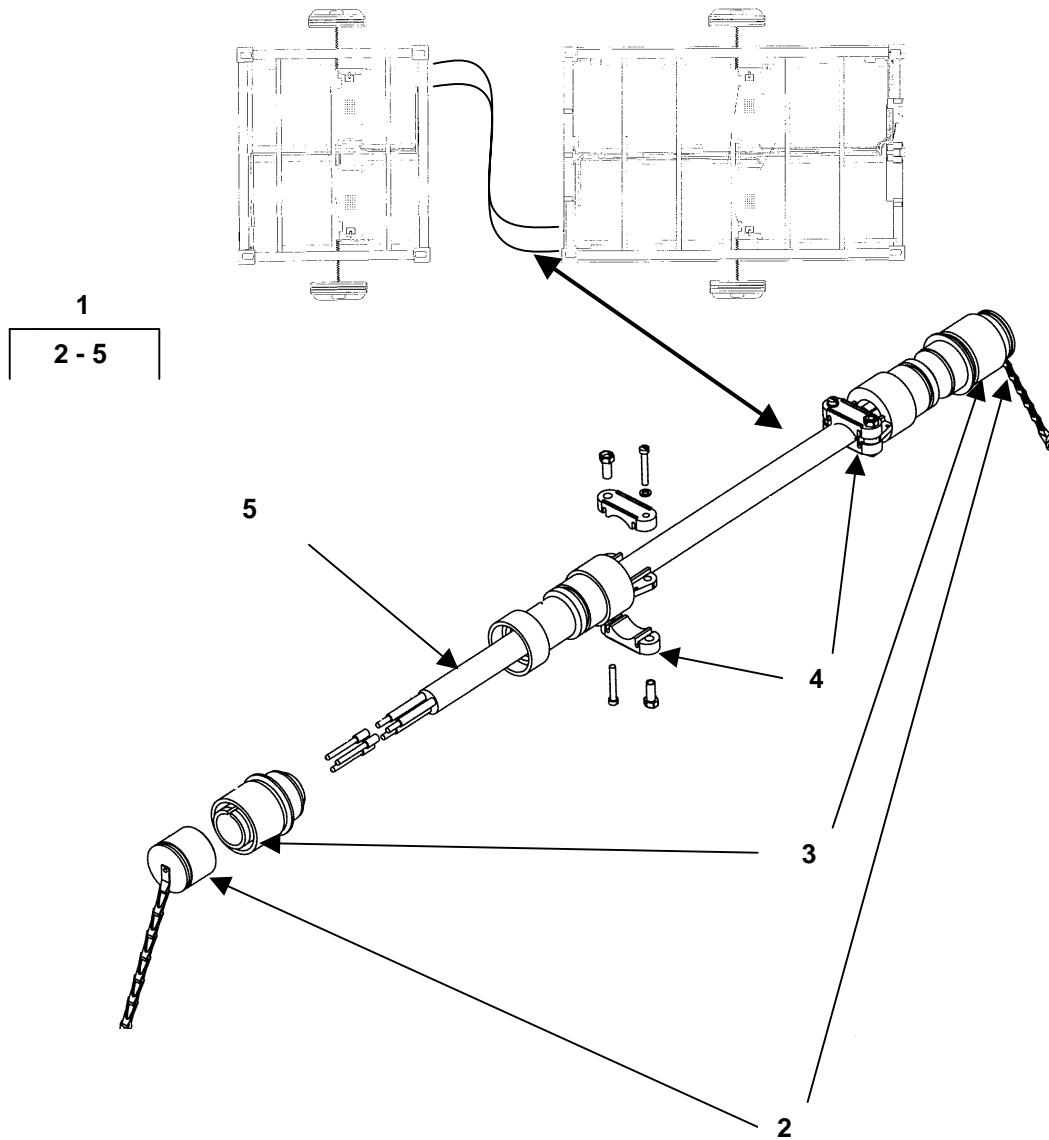

Figure 26. Cable A/C, 9'

(1) ITEM NO.	(2) SMR CODE	(3) NSN	(4) CAGEC	(5) PART NUMBER	(6) DESCRIPTION AND USABLE ON CODE (UOC)	(7) QTY
1	MFOFF		1NSG3	16502556	GROUP 060302 CABLE A/C, 9' FIG. 26 CABLE A/C, 9' CABLE, ASSEMBLY POWER, ELECTRICAL, 9 FT, 120VAC	2
2	PAFZZ	5935-01-189-3220	96906	MS25042-16DA	.COVER, ELECTRICAL CONNECTOR	2
3	PAFZZ	5935-01-026-2217	96906	MS3456W16-10P	.CONNECTOR, PLUG ELECTRICAL	2
4	PAFZZ	5935-01-181-1672	96906	MS85049/11-118W	. ADAPTER, CABLE CLAMP TO CONNECTOR	2
5	MFFZZ		1RDQ0	5W578	.CABLE, POWER ELECTRICAL, 12/3	V
END OF FIGURE						

OPERATOR'S, UNIT AND DIRECT SUPPORT MAINTENANCE

AUTHORIZED STOCKAGE LIST MOBILITY SYSTEM (ASLMS)

**MODEL NUMBER FPU-8/12 PARTS (OD) P/N 15005002-001
NSN 5411-01-523-2071**

**MODEL NUMBER FPU-8/12 PARTS (DS) P/N 15005002-002
NSN 5411-01-523-2072**

**MODEL NUMBER FPU-8/12 BULK (OD) P/N 15005001-001
NSN 5411-01-523-2073**

**MODEL NUMBER FPU-8/12 BULK (DS) P/N 15005001-002
NSN 5411-01-523-2074**

RECEPTACLE GFCI

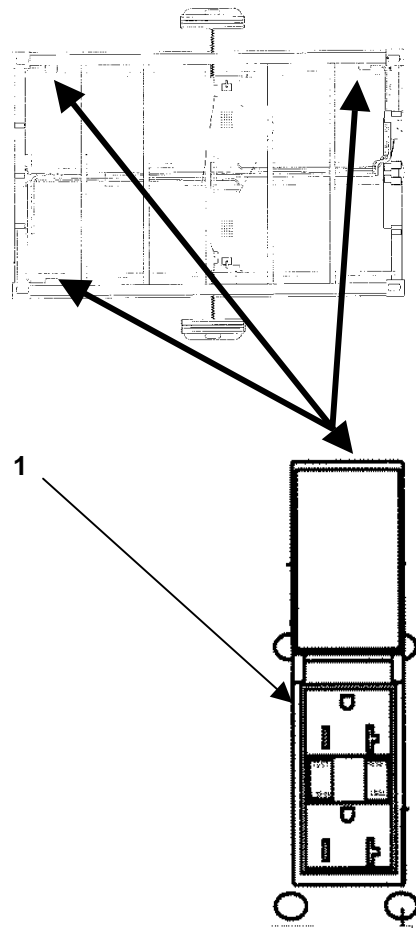

Figure 27. Receptacle GFCI

(1) ITEM NO.	(2) SMR CODE	(3) NSN	(4) CAGEC	(5) PART NUMBER	(6) DESCRIPTION AND USABLE ON CODE (UOC)	(7) QTY
1	XDOZZ		1RDQ0	1FD35	GROUP 060303 RECEPTACLE GFCI FIG. 27 RECEPTACLE GFCI RECEPTACLE, GFCI, 20 A END OF FIGURE	3

OPERATOR'S, UNIT AND DIRECT SUPPORT MAINTENANCE

AUTHORIZED STOCKAGE LIST MOBILITY SYSTEM (ASLMS)

MODEL NUMBER FPU-8/12 PARTS (OD) P/N 15005002-001

NSN 5411-01-523-2071

MODEL NUMBER FPU-8/12 PARTS (DS) P/N 15005002-002

NSN 5411-01-523-2072

MODEL NUMBER FPU-8/12 BULK (OD) P/N 15005001-001

NSN 5411-01-523-2073

MODEL NUMBER FPU-8/12 BULK (DS) P/N 15005001-002

NSN 5411-01-523-2074

CABLE D/C, 9'

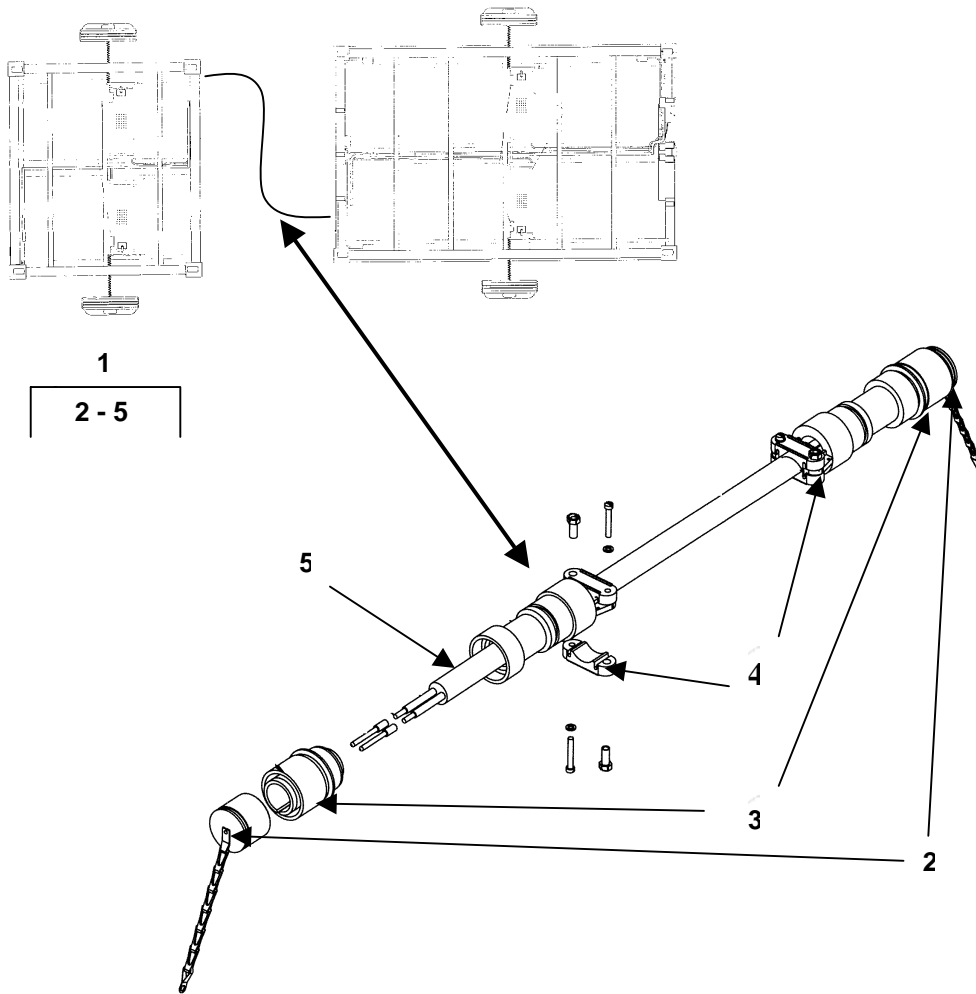

Figure 28. Cable D/C, 9'

(1) ITEM NO.	(2) SMR CODE	(3) NSN	(4) CAGEC	(5) PART NUMBER	(6) DESCRIPTION AND USABLE ON CODE (UOC)	(7) QTY
1	MFOFF		1NSG3	16502557	GROUP 060401 CABLE D/C, 9' FIG. 28 CABLE D/C, 9' CABLE, ASSEMBLY POWER, ELECTRICAL, 9 FT, 12-VOLT D/C POWER	1
2	PAFZZ	5935-01-189-3220	96906	MS25042-16DA	.COVER, ELECTRICAL CONNECTOR	2
3	PAFZZ	5935-01-116-3615	96906	MS3456W16-11P	.CONNECTOR, PLUG, ELECTRICAL	2
4	PAFZZ	5935-01-181-1672	96906	MS85049/11-118W	.ADAPTER, CABLE CLAMP TO CONNECTOR	2
5	MFFZZ		1RDQ0	IW925	.CORD, ELECTRICAL, 14/2	1
END OF FIGURE						

OPERATOR'S, UNIT AND DIRECT SUPPORT MAINTENANCE

AUTHORIZED STOCKAGE LIST MOBILITY SYSTEM (ASLMS)

MODEL NUMBER FPU-8/12 PARTS (OD) P/N 15005002-001

NSN 5411-01-523-2071

MODEL NUMBER FPU-8/12 PARTS (DS) P/N 15005002-002

NSN 5411-01-523-2072

MODEL NUMBER FPU-8/12 BULK (OD) P/N 15005001-001

NSN 5411-01-523-2073

MODEL NUMBER FPU-8/12 BULK (DS) P/N 15005001-002

NSN 5411-01-523-2074

12-VOLT LIGHT ASSEMBLY

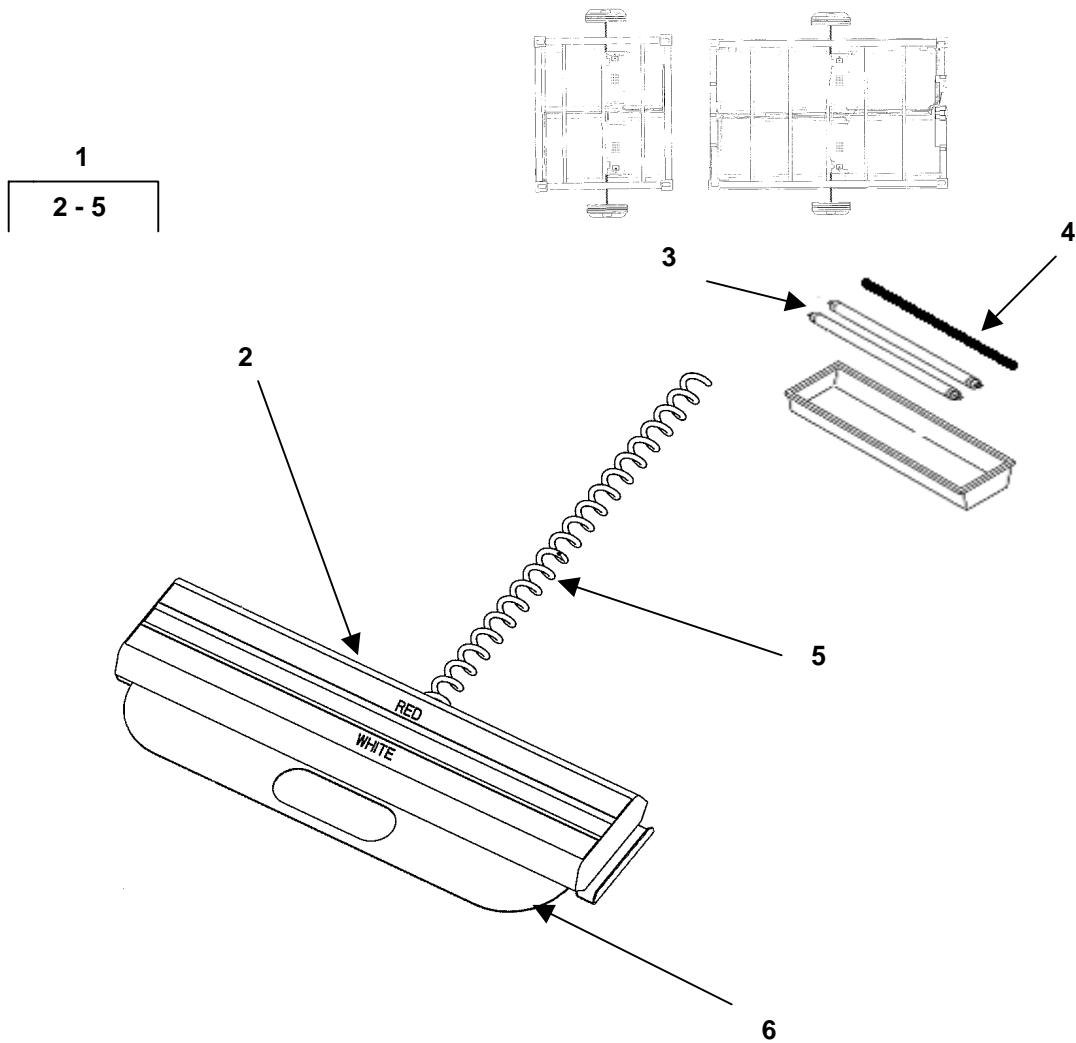

Figure 29. 12-Volt Light Assembly

(1) ITEM NO.	(2) SMR CODE	(3) NSN	(4) CAGEC	(5) PART NUMBER	(6) DESCRIPTION AND USABLE ON CODE (UOC)	(7) QTY
					GROUP 060402 12-VOLT LIGHT ASSEMBLY FIG. 29 12-VOLT LIGHT ASSEMBLY	
1	XDFFF		1NSG3	16500652	LIGHT ASSY, 12V DC.	1
2	XDFZZ		1NSG3	15220102	.LIGHT, FIXTURE	1
3	XDOZZ		1RDQ0	1F406	..LAMP, FLORESCENT	2
4	XDOZZ		07BY4	1626K7	.RED LENS SLEEVE	1
5	XDFZZ		1NSG3	15312470	.CORD, COILED 12 FT	1
6	XDFZZ		1NSG3	16500604	.BRACKET, LIGHT FIXTURE	1
					END OF FIGURE	

OPERATOR'S, UNIT AND DIRECT SUPPORT MAINTENANCE

AUTHORIZED STOCKAGE LIST MOBILITY SYSTEM (ASLMS)

MODEL NUMBER FPU-8/12 PARTS (OD) P/N 15005002-001

NSN 5411-01-523-2071

MODEL NUMBER FPU-8/12 PARTS (DS) P/N 15005002-002

NSN 5411-01-523-2072

MODEL NUMBER FPU-8/12 BULK (OD) P/N 15005001-001

NSN 5411-01-523-2073

MODEL NUMBER FPU-8/12 BULK (DS) P/N 15005001-002

NSN 5411-01-523-2074

LIGHT POLE ASSEMBLY

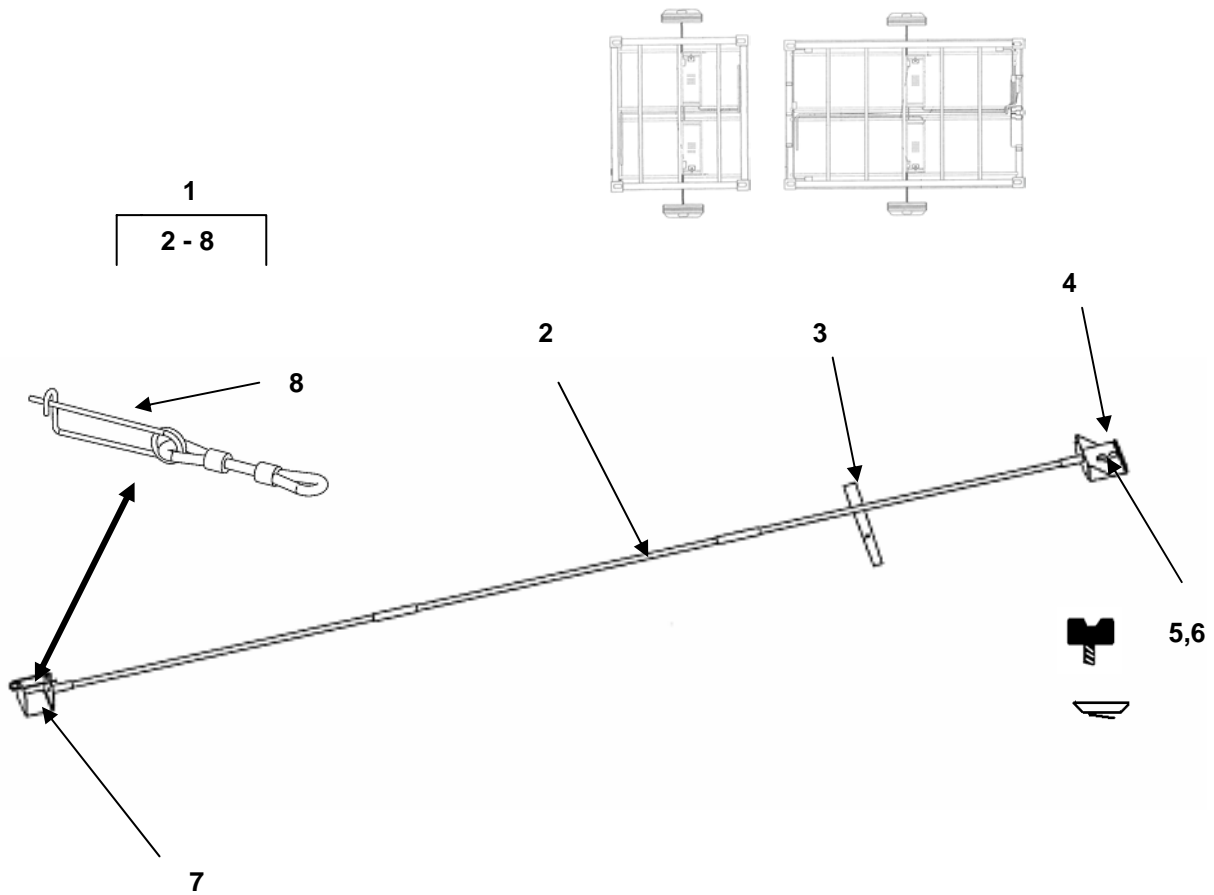

Figure 30. Light Pole Assembly

(1)	(2)	(3)	(4)	(5)	(6)	(7)
ITEM NO.	SMR CODE	NSN	CAGEC	PART NUMBER	DESCRIPTION AND USABLE ON CODE (UOC)	QTY
					GROUP 060403 LIGHT POLE ASSEMBLY FIG. 30 LIGHT POLE ASSEMBLY	
1	PAOOO	5411-01-529-9285	1NSG3	16500653	POLE, LIGHT SUPPORT ASSEMBLY	8
2	XD0ZZ		1NSG3	16500654	.POLE, LIGHT SUPPORT	1
3	XDOZZ		1RDQ0	4YF24	.STRAP, LOOP TIE	1
4	XDOZZ		1NSG3	16500656	.BRACKET ASSEMBLY, LIGHT SUPPORT	1
5	XDOZZ		07BY4	90195A540	..WING SCREW ¼"	1
6	XDOZZ		07YB4	94800A720	..PUSH NUT ¼"	1
7	XDOZZ		1NSG3	16500655	.CLIP ASSY LIGHT SUPPORT	1
8	XDOZZ		1NSG3	15312276	..PIN, SAFETY W/ LANYARD	1
END OF FIGURE						

OPERATOR'S, UNIT AND DIRECT SUPPORT MAINTENANCE

AUTHORIZED STOCKAGE LIST MOBILITY SYSTEM (ASLMS)

MODEL NUMBER FPU-8/12 PARTS (OD) P/N 15005002-001

NSN 5411-01-523-2071

MODEL NUMBER FPU-8/12 PARTS (DS) P/N 15005002-002

NSN 5411-01-523-2072

MODEL NUMBER FPU-8/12 BULK (OD) P/N 15005001-001

NSN 5411-01-523-2073

MODEL NUMBER FPU-8/12 BULK (DS) P/N 15005001-002

NSN 5411-01-523-2074

VENT SYSTEM

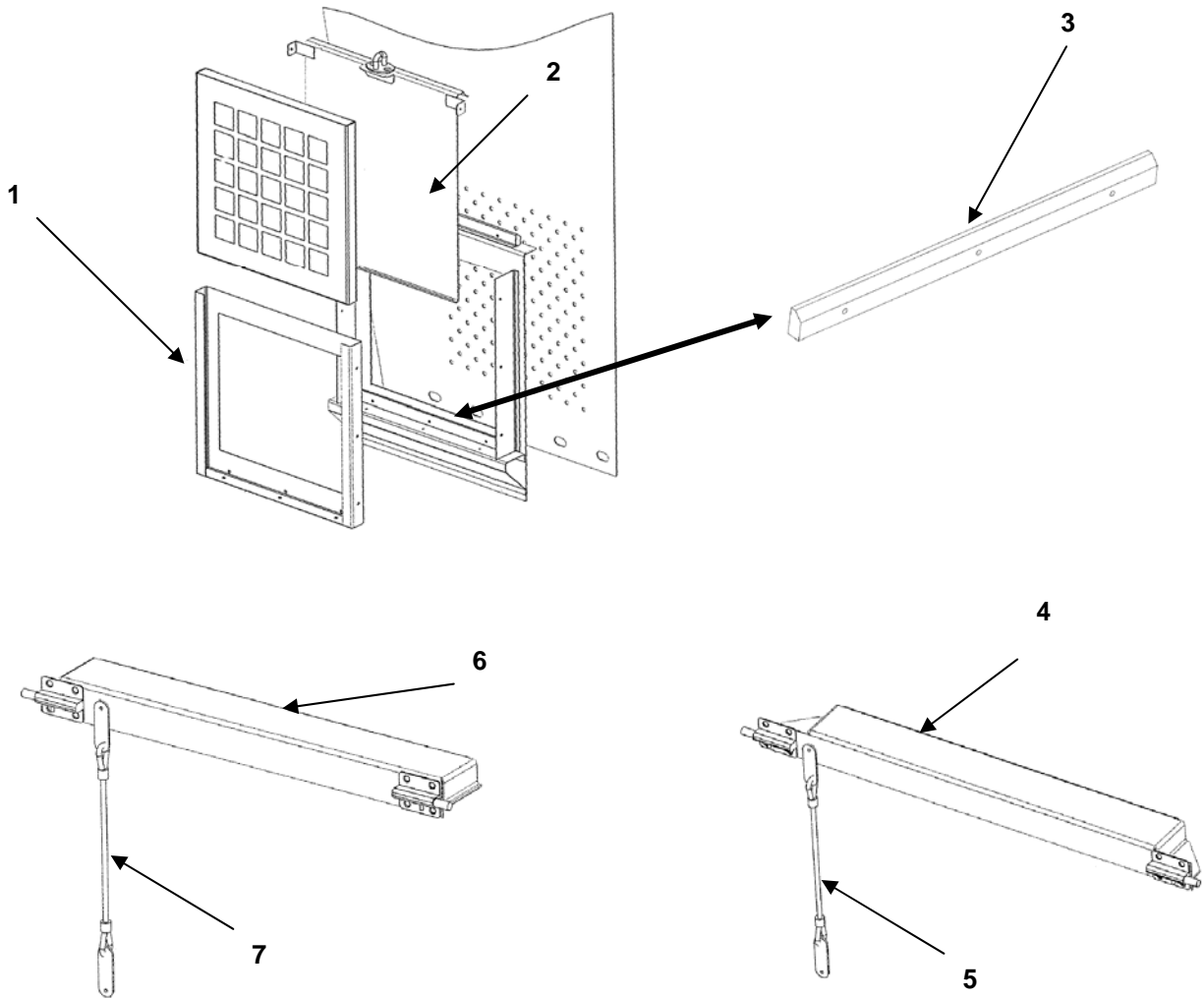

Figure 31. Vent System
(Sheet 1 of 2)

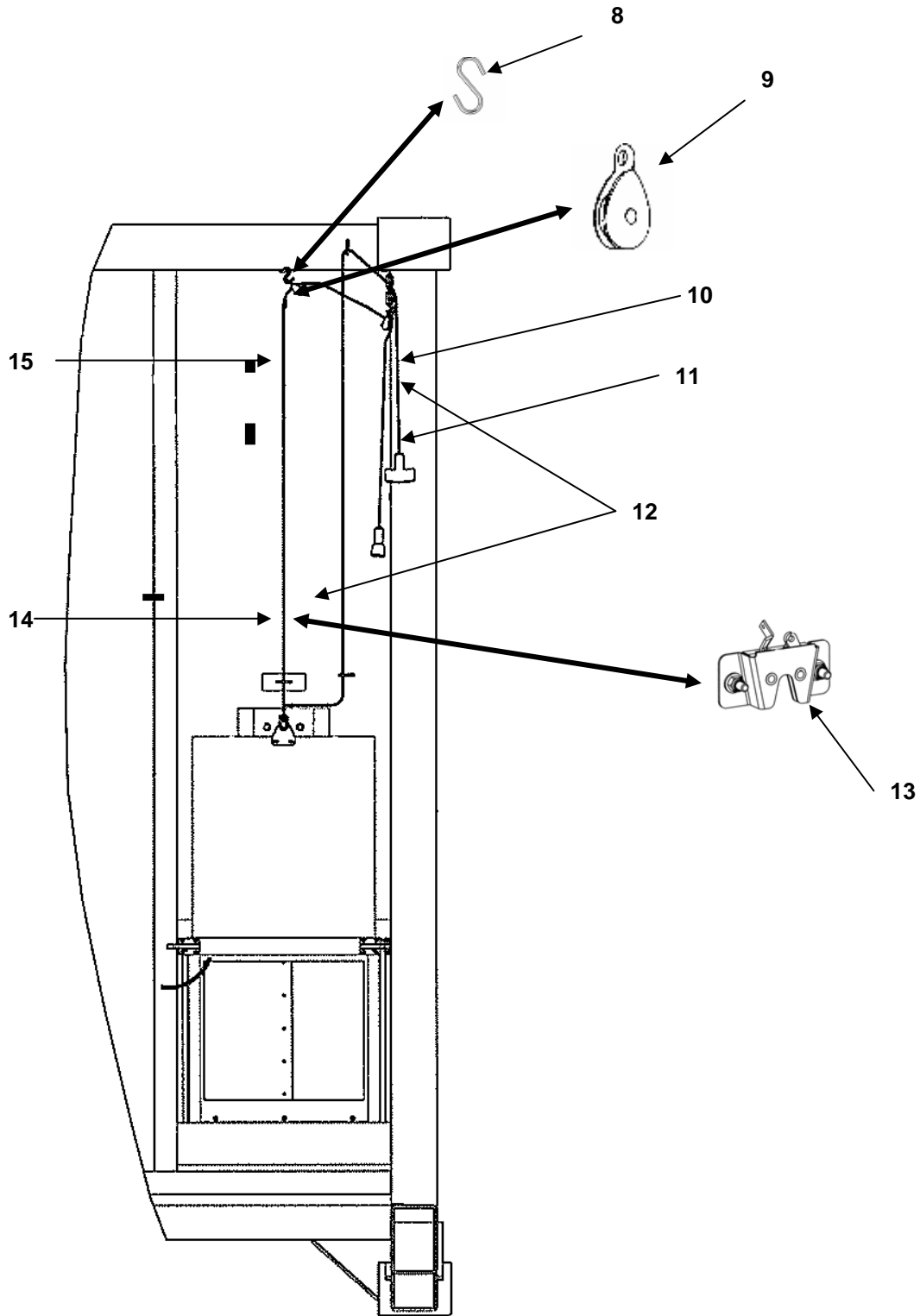

Figure 31. Vent System
(Sheet 2 of 2)

(1)	(2)	(3)	(4)	(5)	(6)	(7)
ITEM NO.	SMR CODE	NSN	CAGEC	PART NUMBER	DESCRIPTION AND USABLE ON CODE (UOC)	QTY
					GROUP 07 VENT SYSTEM FIG. 31 VENT SYSTEM	
1	PAOZZ	5411-01-530-1891	1NSG3	16501406-001	BRACKET, FILTER, OD UOC: FTR, FTS	4
	PAOZZ	5411-01-530-1896	1NSG3	16501406-002	BRACKET, FILTER, DS UOC: FTT, FTU	4
2	PAOZZ	5411-01-529-9294	1NSG3	16501453-001	COVER, VENT OD UOC: FTR, FTS	4
	PAOZZ	5411-01-529-9296	1NSG3	16501453-002	COVER, VENT DS UOC: FTT, FTU	4
3	PAOZZ	5411-01-530-1014	1NSG3	16501402	WEDGE, UHMV, W/ HARDWARE	8
4	PAOZZ	5411-01-529-9289	1NSG3	16501456-001	LID, FILTER RETAINER, UOC: FTR, FTS	3
	PAOZZ	5411-01-529-9291	1NSG3	16501456-002	LID, FILTER RETAINER UOC: FTT, FTU	3
5	PAOZZ	5411-01-529-9295	1NSG3	74010903	.LANYARD	1
6	PAOZZ	5411-01-529-9292	1NSG3	16501455-001	LID, FILTER, BB END UOC: FTR, FTS	1
	PAOZZ	5411-01-529-9293	1NSG3	16501455-002	LID, FILTER, BB END UOC: FTT, FTU	1
7	PAOZZ	5411-01-529-9295	1NSG3	74010903	.LANYARD	1
8	XDOZZ		07BY4	9381T24	S-HOOK, 1-1/12	
9	XDOZZ		0HF91	N243-576	PULLEY, 3/4" SWIVEL	2
10	XDOZZ		666116	980715	HEAT SHRINK, RED	V
11	XDOZZ		08645	808167	HANDLE, GRIP	2
12	XDOZZ		1NSG3	15312285	CABLE STOP	1
13	PAOZZ	5411-01-529-9297	1NSG3	15312223-001	.LATCH, VENT W/HARDWARE UOC: FTR, FTS	1
	PAOZZ	5411-01-529-9298	1NSG3	15312223-002	.LATCH, VENT W/ HARDWARE UOC: FTT, FTU	1
14	XDOZZ		07BY4	3896T2	.CRIMP, CABLE	1
15	MOOZZ		1RDQ0	4KH26	.CABLE 3/32"	V
END OF FIGURE						

OPERATOR'S, UNIT AND DIRECT SUPPORT MAINTENANCE

AUTHORIZED STOCKAGE LIST MOBILITY SYSTEM (ASLMS)

MODEL NUMBER FPU-8/12 PARTS (OD) P/N 15005002-001

NSN 5411-01-523-2071

MODEL NUMBER FPU-8/12 PARTS (DS) P/N 15005002-002

NSN 5411-01-523-2072

MODEL NUMBER FPU-8/12 BULK (OD) P/N 15005001-001

NSN 5411-01-523-2073

MODEL NUMBER FPU-8/12 BULK (DS) P/N 15005001-002

NSN 5411-01-523-2074

VENT FILTER

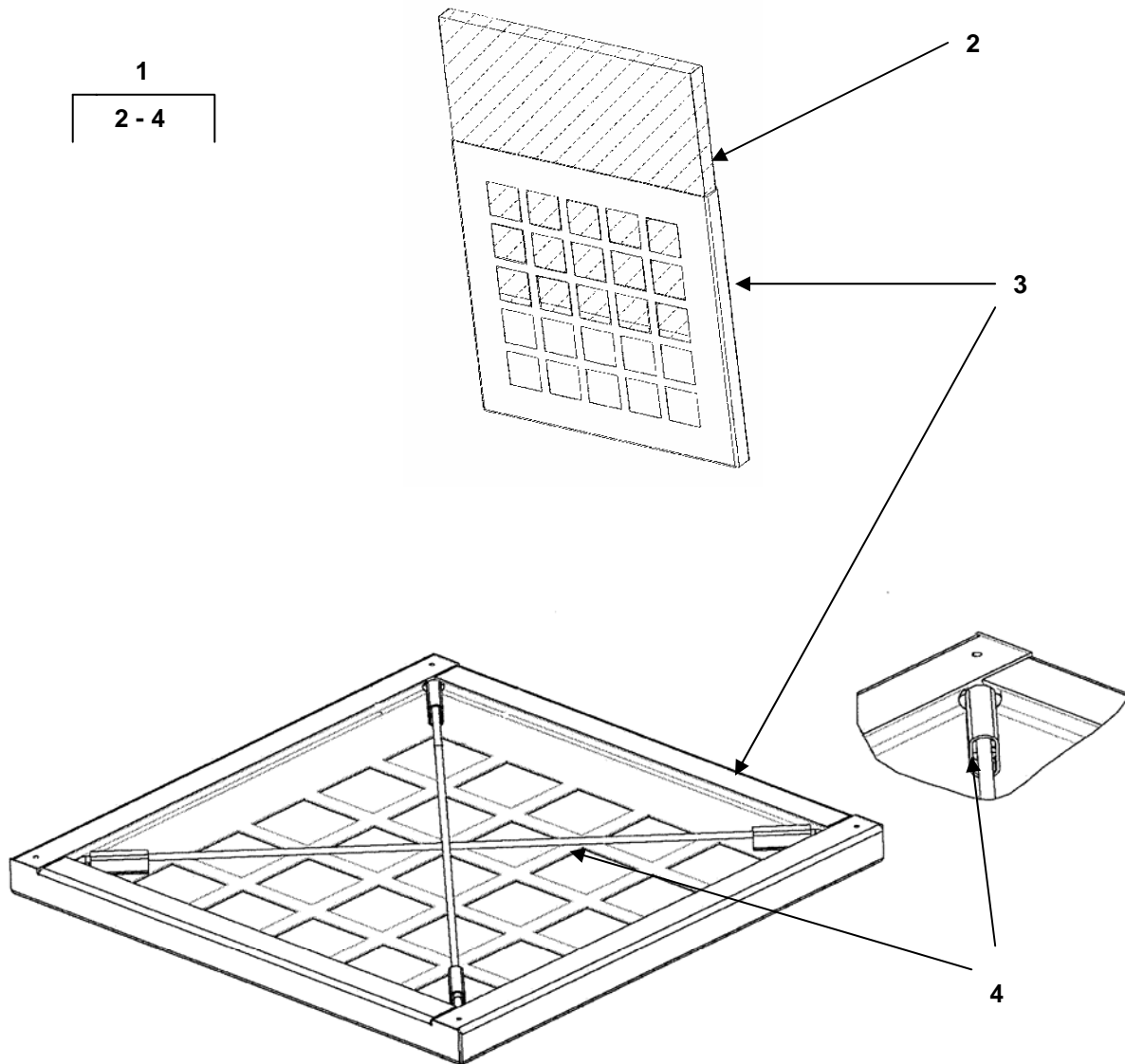

Figure 32. Vent Filter

(1)	(2)	(3)	(4)	(5)	(6)	(7)
ITEM NO.	SMR CODE	NSN	CAGEC	PART NUMBER	DESCRIPTION AND USABLE ON CODE (UOC)	QTY
					GROUP 0701 VENT FILTER FIG. 32 VENT FILTER	
1	PAOZZ	5411-01-529-9299	1NSG3	16501450-001	FILTER ASSY, OD UOC: FTR, FTS	4
	PAOZZ	5411-01-529-9300	1NSG3	16501450-002	FILTER ASSY, DS UOC: FTT, FTU	4
2	PAOZZ		1NSG3	16501462	.FILTER AIR	1
3	XAOZZ		1NSG3	16501401-001	.FILTER HOUSING, OD UOC: FTR, FTS	1
	XAOZZ		1NSG3	16501401-002	.FILTER HOUSING, DS UOC: FTT, FTU	1
4	XDOZZ		1NSG3	16501460	.CORD RETAINER	2
					END OF FIGURE	

OPERATOR'S, UNIT AND DIRECT SUPPORT MAINTENANCE

AUTHORIZED STOCKAGE LIST MOBILITY SYSTEM (ASLMS)

MODEL NUMBER FPU-8/12 PARTS (OD) P/N 15005002-001

NSN 5411-01-523-2071

MODEL NUMBER FPU-8/12 PARTS (DS) P/N 15005002-002

NSN 5411-01-523-2072

MODEL NUMBER FPU-8/12 BULK (OD) P/N 15005001-001

NSN 5411-01-523-2073

MODEL NUMBER FPU-8/12 BULK (DS) P/N 15005001-002

NSN 5411-01-523-2074

EPC ASSEMBLY

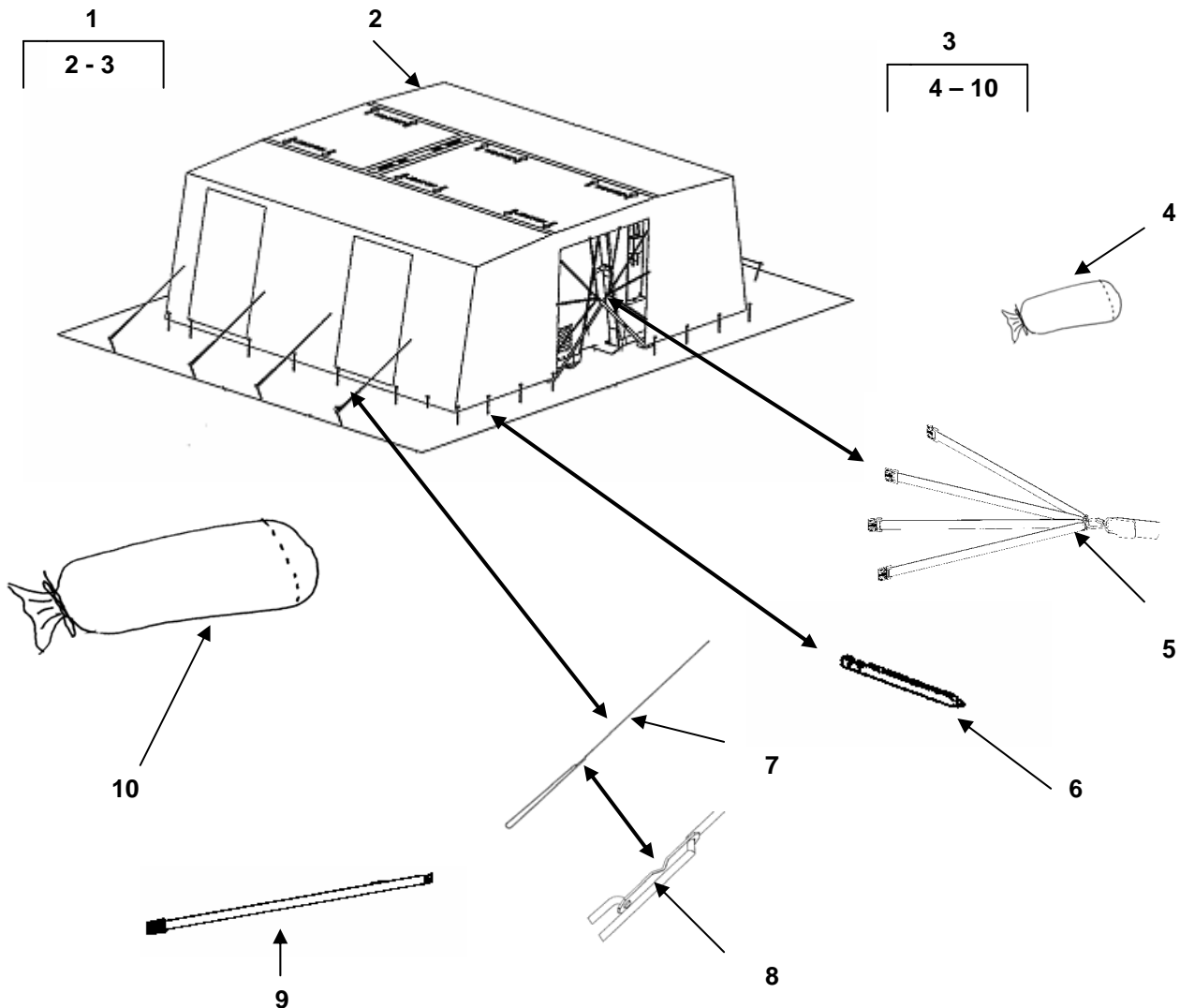

Figure 33. EPC Assembly

(1)	(2)	(3)	(4)	(5)	(6)	(7)
ITEM NO.	SMR CODE	NSN	CAGEC	PART NUMBER	DESCRIPTION AND USABLE ON CODE (UOC)	QTY
GROUP 08 EPC ASSEMBLY FIG. 33 EPC ASSEMBLY						
1	XDOFF		1NSG3	16501800-001	EPC ASSY OD UOC: FTR, FTS	1
	XDOFF		1NSG3	16501800-002	EPC ASSY DS UOC: FTT, FTU	1
2	PAOFF	5411-01-529-9301	1NSG3	16501888-001	.CANVAS, EPC OD UOC: FTR, FTS	1
	PAOFF	5411-01-529-9302	1NSG3	16501888-002	.CANVAS, EPC DS UOC: FTT, FTU	1
3	XDOZZ		1NSG3	16501870-001	.EPC SECURING KIT OD	1
	XDOZZ		1NSG3	16501870-002	.EPC SECURING KIT DS	1
4	XDOZZ		1NSG3	16502657-001	..BAG EPC SECURING KIT UOC: FTR, FTS	1
	XDOZZ		1NSG3	16502657-002	..BAG EPC SECURING KIT UOC: FTT, FTU	1
5	XDOZZ		1NSG3	16502655	..STRAP, ELASTIC, END WALL	1
6	PAOZZ	1080-00-108-1654	81349	MIL-P-501	..STAKE	36
7	XDOZZ		1NSG3	16501857	..GUY ROPE ASSY	8
8	XDOZZ		1NSG3	16501820	...GUY ROPES TENSIONER	1
9	XDOZZ		1NSG3	16501833	..STRAP, ROLLUP	1
10	XDOZZ		1NSG3	16502689-001	..BAG, EPC CANVAS UOC: FTR, FTS	1
	XDOZZ		1NSG3	16502689-002	..BAG, EPC CANVAS UOC: FTT, FTU	1
END OF FIGURE						

OPERATOR'S, UNIT AND DIRECT SUPPORT MAINTENANCE
AUTHORIZED STOCKAGE LIST MOBILITY SYSTEM (ASLMS)

- MODEL NUMBER FPU-8/12 PARTS (OD) P/N 15005002-001
NSN 5411-01-523-2071
- MODEL NUMBER FPU-8/12 PARTS (DS) P/N 15005002-002
NSN 5411-01-523-2072
- MODEL NUMBER FPU-8/12 BULK (OD) P/N 15005001-001
NSN 5411-01-523-2073
- MODEL NUMBER FPU-8/12 BULK (DS) P/N 15005001-002
NSN 5411-01-523-2074

EPC POLES

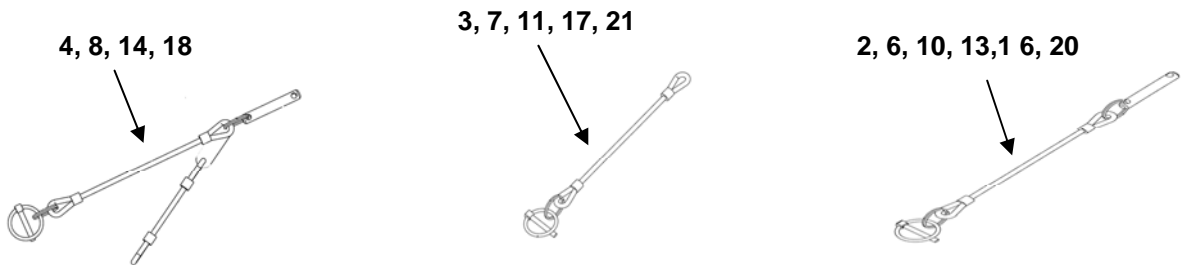
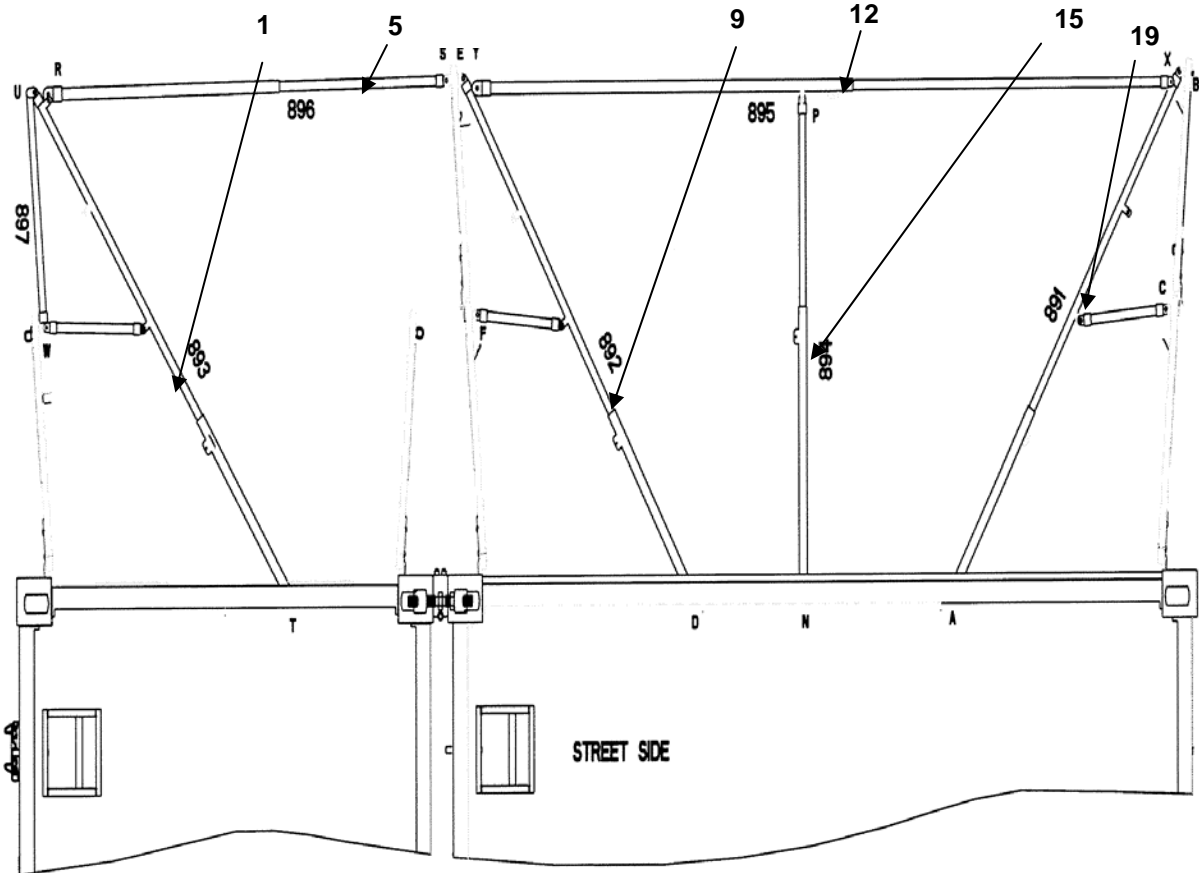

NOTE: FOR PIN ASSEMBLY PARTS SEE FIGURE 35
Figure 34. EPC Poles
(Sheet 1 of 2)

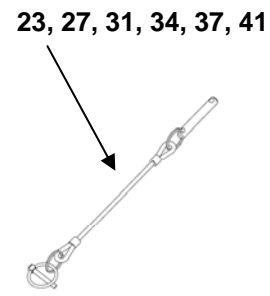
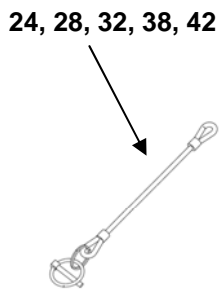
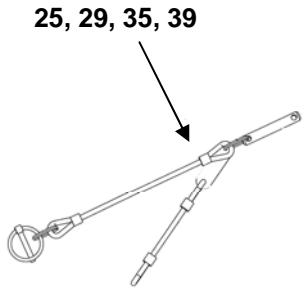
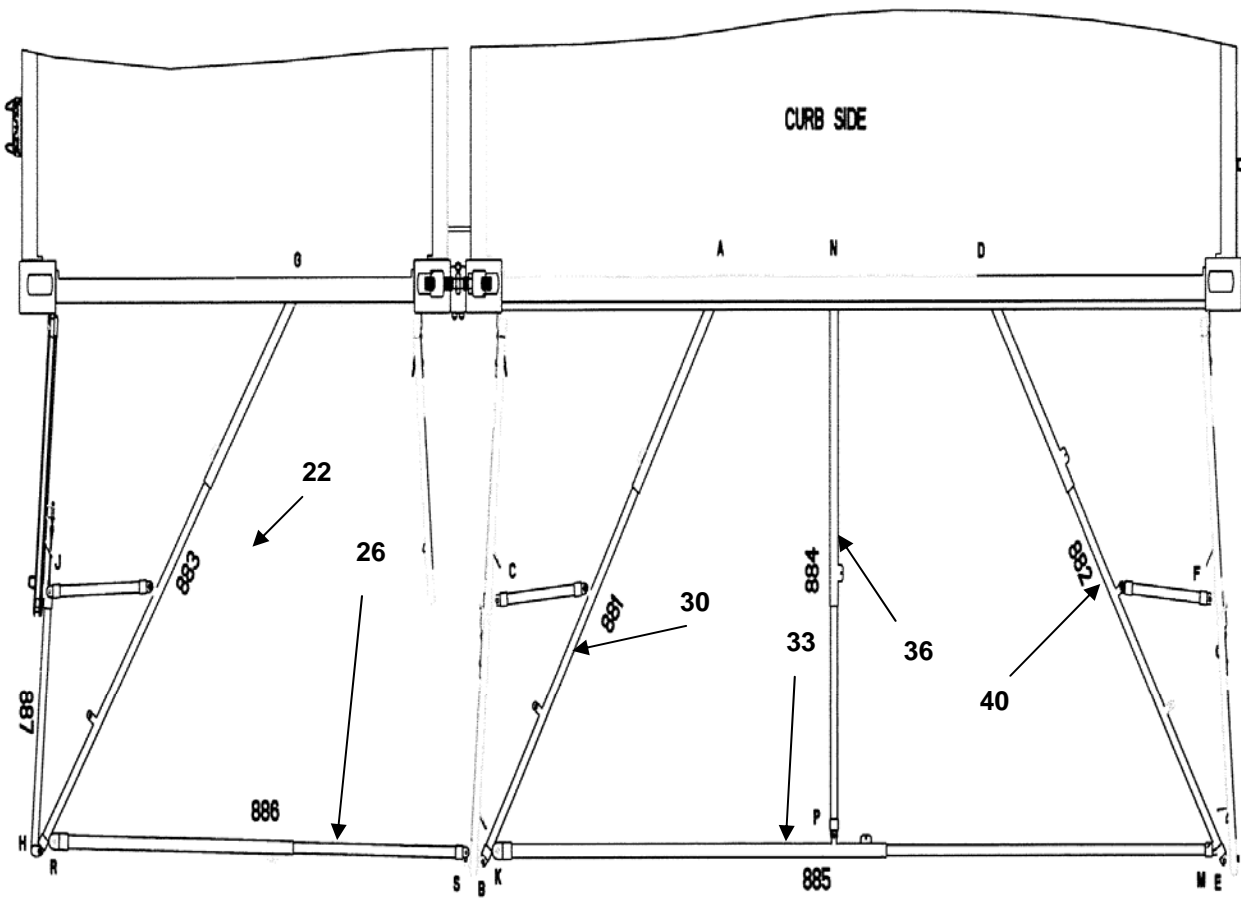

NOTE: FOR PIN ASSEMBLY PARTS SEE FIGURE 35

Figure 34. EPC Poles
(Sheet 2 of 2)

(1)	(2)	(3)	(4)	(5)	(6)	(7)
ITEM NO.	SMR CODE	NSN	CAGEC	PART NUMBER	DESCRIPTION AND USABLE ON CODE (UOC)	QTY
					GROUP 09 EPC POLES FIG. 34 EPC POLES	
1	PAOOO	5411-01-529-9303	1NSG3	16501893-001	POLE ASSY, EPC, SS, OD UOC: FTR, FTS	1
	PAOOO	5411-01-529-9305	1NSG3	16501893-002	POLE ASSY, EPC, SS, DS UOC: FTT, FTU	1
2	PAOOO	5411-01-530-3804	1NSG3	16501860	.PIN ASSEMBLY, POLE, 1	1
3	PAOOO	5411-01-530-1027	1NSG3	16501873	.PIN ASSEMBLY, POLE, 2	1
4	PAOOO	5411-01-530-1028	1NSG3	16501874	.PIN ASSEMBLY, POLE, 3	2
5	PAOOO	5411-01-529-9306	1NSG3	16501896-001	POLE ASSY, EPC, SS, OD UOC: FTR, FTS	1
	PAOOO	5411-01-529-9307	1NSG3	16501896-002	POLE ASSY, EPC, SS, DS UOC: FTT, FTU	1
6	PAOOO	5411-01-530-3804	1NSG3	16501860	.PIN ASSEMBLY, POLE, 1	1
7	PAOOO	5411-01-530-1027	1NSG3	16501873	.PIN ASSEMBLY, POLE, 2	1
8	PAOOO	5411-01-530-1028	1NSG3	16501874	.PIN ASSEMBLY, POLE, 3	1
9	PAOOO	5411-01-529-9308	1NSG3	16501892-001	POLE ASSY, EPC, SS, OD UOC: FTR, FTS	1
	PAOOO	5411-01-529-9243	1NSG3	16501892-002	POLE ASSY, EPC, SS, DS UOC: FTT, FTU	1
10	PAOOO	5411-01-530-3804	1NSG3	16501860	.PIN ASSEMBLY, POLE, 1	1
11	PAOOO	5411-01-530-1027	1NSG3	16501873	.PIN ASSEMBLY, POLE, 2	3
12	PAOOO	5411-01-529-9244	1NSG3	16501895-001	.POLE ASSY, EPC, SS, OD UOC: FTR, FTS	1
	PAOOO	5411-01-529-9245	1NSG3	16501895-002	POLE ASSY, EPC, SS, DS UOC: FTT, FTU	1
13	PAOOO	5411-01-530-3804	1NSG3	16501860	.PIN ASSEMBLY, POLE, 1	1
14	PAOOO	5411-01-530-1028	1NSG3	16501874	.PIN ASSEMBLY, POLE, 3	2
15	PAOOO	5411-01-529-9246	1NSG3	16501894-001	POLE ASSY, EPC, SS, OD UOC: FTR, FTS	1
	PAOOO	5411-01-529-9248	1NSG3	16501894-002	POLE ASSY, EPC, SS, DS UOC: FTT, FTU	1
16	PAOOO	5411-01-530-3804	1NSG3	16501860	.PIN ASSEMBLY, POLE, 1	1
17	PAOOO	5411-01-530-1027	1NSG3	16501873	.PIN ASSEMBLY, POLE, 2	1
18	PAOOO	5411-01-530-1028	1NSG3	16501874	.PIN ASSEMBLY, POLE, 3	1

(1)	(2)	(3)	(4)	(5)	(6)	(7)
ITEM NO.	SMR CODE	NSN	CAGEC	PART NUMBER	DESCRIPTION AND USABLE ON CODE (UOC)	QTY
19	PAOOO	5411-01-529-9247	1NSG3	16501891-001	POLE ASSY, EPC, SS, OD UOC: FTR, FTS	1
	PAOOO	5411-01-530-1031	1NSG3	16501891-002	POLE ASSY, EPC, SS, DS UOC: FTT, FTU	1
20	PAOOO	5411-01-530-3804	1NSG3	16501860	.PIN ASSEMBLY, POLE, 1	1
21	PAOOO	5411-01-530-1027	1NSG3	16501873	.PIN ASSEMBLY, POLE, 2	3
22	PAOOO	5411-01-530-1034	1NSG3	16501883-001	POLE ASSY, EPC, CS, OD UOC: FTR, FTS	1
	PAOOO	5411-01-529-9803	1NSG3	16501883-002	POLE ASSY, EPC, CS, DS UOC: FTT, FTU	1
23	PAOOO	5411-01-530-3804	1NSG3	16501860	.PIN ASSEMBLY, POLE, 1	1
24	PAOOO	5411-01-530-1027	1NSG3	16501873	.PIN ASSEMBLY, POLE, 2	1
25	PAOOO	5411-01-530-1028	1NSG3	16501874	.PIN ASSEMBLY, POLE, 3	2
26	PAOOO	5411-01-529-9802	1NSG3	16501886-001	POLE ASSY, EPC, CS, OD UOC: FTR, FTS	1
	PAOOO	5411-01-529-9801	1NSG3	16501886-002	POLE ASSY, EPC, CS, DS UOC: FTT, FTU	1
27	PAOOO	5411-01-530-3804	1NSG3	16501860	.PIN ASSEMBLY, POLE, 1	1
28	PAOOO	5411-01-530-1027	1NSG3	16501873	.PIN ASSEMBLY, POLE, 2	1
29	PAOOO	5411-01-530-1028	1NSG3	16501874	.PIN ASSEMBLY, POLE, 3	1
30	PAOOO	5411-01-530-1086	1NSG3	16501881-001	POLE ASSY, EPC, CS, OD UOC: FTR, FTS	1
	PAOOO	5411-01-530-1037	1NSG3	16501881-002	POLE ASSY, EPC, CS, DS UOC: FTT, FTU	1
31	PAOOO	5411-01-530-3804	1NSG3	16501860	.PIN ASSEMBLY, POLE, 1	1
32	PAOOO	5411-01-530-1027	1NSG3	16501873	.PIN ASSEMBLY, POLE, 2	3
33	PAOOO	5411-01-530-1038	1NSG3	16501885-001	. POLE ASSY, EPC, CS, OD UOC: FTR, FTS	1
	PAOOO	5411-01-530-1039	1NSG3	16501885-002	POLE ASSY, EPC, CS, DS UOC: FTT, FTU	1
34	PAOOO	5411-01-530-3804	1NSG3	16501860	.PIN ASSEMBLY, POLE, 1	1

(1)	(2)	(3)	(4)	(5)	(6)	(7)
ITEM NO.	SMR CODE	NSN	CAGEC	PART NUMBER	DESCRIPTION AND USABLE ON CODE (UOC)	QTY
35	PAOOO	5411-01-530-1028	1NSG3	16501874	.PIN ASSEMBLY, POLE, 3	1
36	PAOOO	5411-01-530-1040	1NSG3	16501884-001	POLE ASSY, EPC, CS, OD UOC: FTR, FTS	1
	PAOOO	5411-01-530-1041	1NSG3	16501884-002	POLE ASSY, EPC, CS, DS UOC: FTT, FTU	1
37	PAOOO	5411-01-530-3804	1NSG3	16501860	.PIN ASSEMBLY, POLE, 1	1
38	PAOOO	5411-01-530-1027	1NSG3	16501873	.PIN ASSEMBLY, POLE, 2	1
39	PAOOO	5411-01-530-1028	1NSG3	16501874	.PIN ASSEMBLY, POLE, 3	1
40	PAOOO	5411-01-530-1025	1NSG3	16501882-001	POLE ASSY, EPC, CS, OD UOC: FTR, FTS	1
	PAOOO	5411-01-530-1024	1NSG3	16501882-002	POLE ASSY, EPC, CS, DS UOC: FTT, FTU	1
41	PAOOO	5411-01-530-3804	1NSG3	16501860	.PIN ASSEMBLY, POLE, 1	1
42	PAOOO	5411-01-530-1027	1NSG3	16501873	.PIN ASSEMBLY, POLE, 2	3
END OF FIGURE						

OPERATOR'S, UNIT AND DIRECT SUPPORT MAINTENANCE

AUTHORIZED STOCKAGE LIST MOBILITY SYSTEM (ASLMS)

MODEL NUMBER FPU-8/12 PARTS (OD) P/N 15005002-001
NSN 5411-01-523-2071

MODEL NUMBER FPU-8/12 PARTS (DS) P/N 15005002-002
NSN 5411-01-523-2072

MODEL NUMBER FPU-8/12 BULK (OD) P/N 15005001-001
NSN 5411-01-523-2073

MODEL NUMBER FPU-8/12 BULK (DS) P/N 15005001-002
NSN 5411-01-523-2074

PIN W/ LANYARD

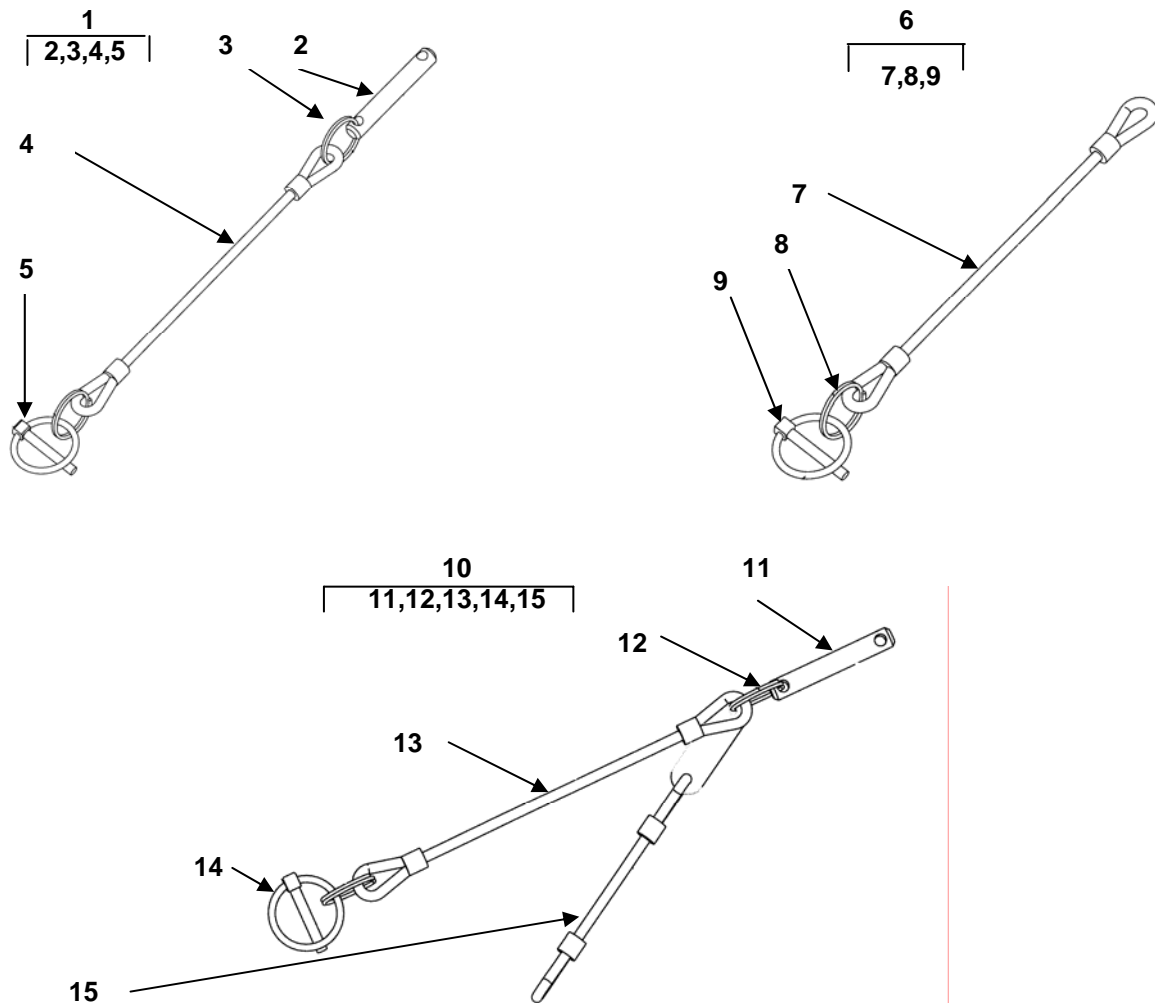

Figure 35. Pin W/ Lanyard

(1)	(2)	(3)	(4)	(5)	(6)	(7)
ITEM NO.	SMR CODE	NSN	CAGEC	PART NUMBER	DESCRIPTION AND USABLE ON CODE (UOC)	QTY
					GROUP 0901 PIN W/ LANYARD FIG. 35 PIN W/ LANYARD	
1	PAOOO	5411-01-530-3804	1NSG3	16501860	PIN ASSEMBLY, POLE, 1	1
2	XDOZZ		1NSG3	16501822	PIN SS 3/8" x 2 7/16"	1
3	XDAZZ		07BY4	90177A217	.KEY RING, 7/8"	2
4	XDOZZ		1NSG3	15120642	.LANYARD 10"	1
5	XDOZZ		1RDQ0	90170A650	.PIN, LYNCH, 3/16"	1
6	PAOOO	5411-01-530-1027	1NSG3	16501873	PIN ASSEMBLY, POLE, 2	1
7	XDOZZ		1NSG3	15120642	LANYARD 10"	1
8	XDAZZ		07BY4	90177A217	..KEY RING 7/8"	1
9	XDOZZ		1RDQ0	90170A650	PIN, LYNCH 3/16"	1
10	PAOOO	5411-01-530-1028	1NSG3	16501874	PIN ASSEMBLY, POLE, 3	1
11	XDOZZ		1NSG3	16501822	PIN SS 3/8" x 2 7/16"	1
12	XDAZZ		07BY4	90177A217	..KEY RING 7/8"	2
13	XDOZZ		1NSG3	15120642	LANYARD 10"	1
14	XDOZZ		1RDQ0	90170A650	PIN, LYNCH 3/16"	1
15	XDOZZ		1NSG3	15312267	LANYARD, 6", W/ TAB	1
END OF FIGURE						

OPERATOR'S, UNIT AND DIRECT SUPPORT MAINTENANCE

AUTHORIZED STOCKAGE LIST MOBILITY SYSTEM (ASLMS)

**MODEL NUMBER FPU-8/12 PARTS (OD) P/N 15005002-001
NSN 5411-01-523-2071**

**MODEL NUMBER FPU-8/12 PARTS (DS) P/N 15005002-002
NSN 5411-01-523-2072**

**MODEL NUMBER FPU-8/12 BULK (OD) P/N 15005001-001
NSN 5411-01-523-2073**

**MODEL NUMBER FPU-8/12 BULK (DS) P/N 15005001-002
NSN 5411-01-523-2074**

SPECIAL TOOLS LIST

(1) ITEM NO.	(2) SMR CODE	(3) NSN	(4) CAGEC	(5) PART NUMBER	(6) DESCRIPTION AND USABLE ON CODE (UOC)	(7) QTY

END OF WORK PACKAGE

OPERATOR'S, UNIT AND DIRECT SUPPORT MAINTENANCE

AUTHORIZED STOCKAGE LIST MOBILITY SYSTEM (ASLMS)

MODEL NUMBER FPU-8/12 PARTS (OD) P/N 15005002-001

NSN 5411-01-523-2071

MODEL NUMBER FPU-8/12 PARTS (DS) P/N 15005002-002

NSN 5411-01-523-2072

MODEL NUMBER FPU-8/12 BULK (OD) P/N 15005001-001

NSN 5411-01-523-2073

MODEL NUMBER FPU-8/12 BULK (DS) P/N 15005001-002

NSN 5411-01-523-2074

NATIONAL STOCK NUMBER (NSN) INDEX

STOCK NUMBER	FIG.	ITEM	STOCK NUMBER	FIG.	ITEM
1080	00-108-1654	33 6	5411	01-529-8355	3 4
5410	00-984-5065	19 2	5411	01-529-8356	3 6
5410	01-363-7086	20 2	5411	01-529-8359	3 8
5315	01-483-8825	22 3	5411	01-529-8361	3 6
		22 8	5411	01-529-8363	3 7
5411	01-523-2071	1 1	5411	01-529-8364	3 5
5411	01-523-2072	1 1	5411	01-529-8367	3 7
5411	01-523-2073	1 2	5411	01-529-8368	3 5
5411	01-523-2074	1 2	5411	01-529-8370	3 13
5411	01-529-1028	34 8	5411	01-529-8371	3 13
5411	01-529-8316	7 4	5411	01-529-8372	3 24
		7 8	5411	01-529-8373	3 24
		7 13	5411	01-529-8374	3 29
		9 16	5411	01-529-8375	4 9
		9 19			16 9
5411	01-529-8317	7 1	5411	01-529-8376	3 29
5411	01-529-8318	7 5	5411	01-529-8377	5 1
5411	01-529-8319	7 10	5411	01-529-8378	5 6
5411	01-529-8320	7 5	5411	01-529-8379	5 2
5411	01-529-8321	7 10	5411	01-529-8380	5 6
5411	01-529-8325	7 9	5411	01-529-8381	5 2
5411	01-529-8326	7 14	5411	01-529-8382	6 1
5411	01-529-8332	3 2	5411	01-529-8383	5 1
5411	01-529-8333	2 2	5411	01-529-8384	6 1
		2 8	5411	01-529-8385	6 2
		11 2			7 1
		11 8	5411	01-529-9172	13 1
5411	01-529-8334	2 2	5411	01-529-9173	12 20
		2 8	5411	01-529-9174	12 20
		11 2	5411	01-529-9176	13 1
		11 8	5411	01-529-9177	13 5
5411	01-529-8339	3 3	5411	01-529-9178	13 6
5411	01-529-8343	3 1	5411	01-529-9179	13 7
5411	01-529-8344	3 3	5411	01-529-9180	13 3
5411	01-529-8349	3 4	5411	01-529-9181	7 17
5411	01-529-8350	3 1	5411	01-529-9182	12 2
5411	01-529-8352	3 8	5411	01-529-9183	14 5
5411	01-529-8354	3 2	5411	01-529-9184	8 1

STOCK NUMBER	FIG.	ITEM	STOCK NUMBER	FIG.	ITEM
5411	01-529-9185	15 1	5411	01-529-9238	11 1
5411	01-529-9186	9 1	5411	01-529-9239	12 19
5411	01-529-9187	8 6	5411	01-529-9240	12 18
5411	01-529-9188	15 1	5411	01-529-9241	12 4
5411	01-529-9190	13 8	5411	01-529-9242	12 19
5411	01-529-9192	9 1	5411	01-529-9243	34 9
5411	01-529-9193	14 1	5411	01-529-9244	34 12
5411	01-529-9195	9 6	5411	01-529-9245	34 12
5411	01-529-9196	7 15	5411	01-529-9246	34 15
5411	01-529-9199	14 1	5411	01-529-9247	34 19
5411	01-529-9201	9 6	5411	01-529-9248	34 16
5411	01-529-9204	9 17	5411	01-529-9249	4 9
5411	01-529-9207	9 11	5411	01-529-9249	16 9
5411	01-529-9208	9 11	5411	01-529-9250	15 2
5411	01-529-9210	9 17		01-529-9251	15 2
5411	01-529-9211	9 23	5411	01-529-9252	15 7
5411	01-529-9213	9 4	5411	01-529-9253	15 7
		9 9	5411	01-529-9254	15 11
		9 13			22 1
		9 21	5411	01-529-9255	15 11
		17 4	5411	01-529-9256	15 12
5411	01-529-9216	9 3	5411	01-529-9257	15 12
		9 8	5411	01-529-9258	15 15
		9 12	5411	01-529-9259	15 15
5411	01-529-9216	17 3	5411	01-529-9260	15 16
5411	01-529-9217	9 26	5411	01-529-9261	15 16
5411	01-529-9218	10 1	5411	01-529-9262	15 18
		18 1	5411	01-529-9263	15 25
5411	01-529-9219	9 24	5411	01-529-9264	15 29
5411	01-529-9221	10 15	5411	01-529-9265	15 29
		18 15	5411	01-529-9266	15 30
5411	01-529-9224	10 1	5411	01-529-9267	15 34
		18 1	5411	01-529-9268	17 1
5411	01-529-9225	11 1	5411	01-529-9269	17 1
5411	01-529-9226	10 29	5411	01-529-9270	17 7
5411	01-529-9227	10 15	5411	01-529-9271	18 29
		18 15	5411	01-529-9272	18 29
5411	01-529-9228	10 30	5411	01-529-9273	15 17
		10 5	5411	01-529-9274	20 4
5411	01-529-9229	10 19			21 1
5411	01-529-9229	18 5	5411	01-529-9275	20 4
		18 19			21 1
5411	01-529-9230	10 5	5411	01-529-9279	23 1
		10 19	5411	01-529-9280	22 2
		18 5			7
		18 19	5411	01-529-9282	22 6
5411	01-529-9231	11 7	5411	01-529-9283	23 1
5411	01-529-9232	10 30	5411	01-529-9285	23 11
5411	01-529-9233	12 3			30 1
5411	01-529-9234	11 7	5411	01-529-9286	23 19
5411	01-529-9235	12 2	5411	01-529-9287	24 1
5411	01-529-9236	12 3	5411	01-529-9289	31 4
5411	01-529-9237	12 18	5411	01-529-9290	24 1

STOCK NUMBER	FIG.	ITEM	STOCK NUMBER	FIG.	ITEM
5411	01-529-9291	31 4	5411	01-530-1027	34 7
5411	01-529-9292	31 6			34 11
5411	01-529-9293	31 6			34 17
5411	01-529-9294	31 2			34 21
5411	01-529-9295	31 5			34 24
		31 7			34 28
5411	01-529-9296	31 2			34 32
5411	01-529-9297	31 13			34 38
5411	01-529-9298	31 13			34 42
5411	01-529-9299	32 1	5411	01-530-1027	35 6
5411	01-529-9300	32 1	5411	01-530-1028	34 4
5411	01-529-9301	33 2			34 8
5411	01-529-9302	33 2			34 14
5411	01-529-9303	34 1			34 18
5411	01-529-9305	34 1			34 25
5411	01-529-9306	34 5			34 29
5411	01-529-9307	34 5			34 35
5411	01-529-9308	34 9			34 39
		34 12	5411	01-530-1028	35 10
		34 15	5411	01-530-1029	12 1
5411	01-529-9801	34 26	5411	01-530-1030	5 7
5411	01-529-9802	34 26			15 13
5411	01-529-9803	34 22			22 4
5411	01-530-0999	12 6			22 9
5411	01-530-1001	15 24	5411	01-530-1031	34 19
5411	01-530-1003	2 7	5411	01-530-1032	12 4
5411	01-530-1004	15 34	5411	01-530-1033	14 5
5411	01-530-1005	3 12	5411	01-530-1034	34 22
5411	01-530-1006	2 7	5411	01-530-1035	15 23
5411	01-530-1007	19 1	5411	01-530-1037	34 30
5411	01-530-1009	3 9	5411	01-530-1038	34 33
5411	01-530-1010	2 1	5411	01-530-1039	34 33
5411	01-530-1011	7 15	5411	01-530-1040	34 36
5411	01-530-1012	19 1	5411	01-530-1041	34 36
5411	01-530-1013	3 10	5411	01-530-1042	12 5
5411	01-530-1014	31 3	5411	01-530-1086	34 30
5411	01-530-1015	4 1	5411	01-530-1891	31 1
		16 1	5411	01-530-1892	20 3
5411	01-530-1016	2 1	5411	01-530-1893	23 11
5411	01-530-1017	3 11	5411	01-530-1895	24 4
5411	01-530-1018	22 6	5411	01-530-1896	31 1
5411	01-530-1019	4 1	5411	01-530-3804	34 2
		16 1			34 6
5411	01-530-1020	4 4			34 10
		16 4			34 13
5411	01-530-1021	4 4			34 16
		16 4			34 20
5411	01-530-1022	22 1			34 23
5411	01-530-1023	23 19			34 27
5411	01-530-1024	34 40			34 31
5411	01-530-1025	34 40			34 34
5411	01-530-1026	12 1			34 37
5411	01-530-1027	34 3			34 41

STOCK NUMBER	FIG.	ITEM
5411	01-530-3804	35 1
5411	01-530-4608	15 23
5935	01-116-3615	28 3
5935	01-151-1245	23 14
5935	01-160-1788	23 13
5935	01-160-1788	23 21
5935	01-181-1672	23 7
5935	01-181-1672	25 4
5935	01-181-1672	26 4
5935	01-181-1672	28 4
5935	01-184-7188	23 15
5935	01-184-7188	23 22
5935	01-184-7188	25 2
5935	01-189-3220	23 9
5935	01-189-3220	25 6
5935	01-189-3220	26 2
5935	01-189-3220	28 2
5935	01-260-9595	25 3

OPERATOR'S, UNIT AND DIRECT SUPPORT MAINTENANCE

AUTHORIZED STOCKAGE LIST MOBILITY SYSTEM (ASLMS)

**MODEL NUMBER FPU-8/12 PARTS (OD) P/N 15005002-001
NSN 5411-01-523-2071**

**MODEL NUMBER FPU-8/12 PARTS (DS) P/N 15005002-002
NSN 5411-01-523-2072**

**MODEL NUMBER FPU-8/12 BULK (OD) P/N 15005001-001
NSN 5411-01-523-2073**

**MODEL NUMBER FPU-8/12 BULK (DS) P/N 15005001-002
NSN 5411-01-523-2074**

PART NUMBER (P/N) INDEX

PART NUMBER	FIG.	ITEM	PART NUMBER	FIG.	ITEM
1023056	3	36	15121055	8	10
	9	28	15121249	12	10
	12	15	15220102	29	2
	17	9	1522021	24	4
12900BA-1PZ	20	2	15240152	9	25
15005001-001	1	2		17	6
15005001-002	1	2	15310001-001	13	1
15005002-001	1	1	15310001-002	13	1
15005002-002	1	1	15310101-001	20	1
15005012- 001	11	1	15310101-002	20	1
15005012- 002	11	1	15312220	20	3
15005013-001	2	7	15312223-001	31	13
15005013-002	2	7	15312223-002	31	13
15005015- 001	11	7	15312262	13	9
15005015- 002	11	7	15312276	30	8
15005016-001	2	1	15312286	13	3
15005016-002	2	1	15312433-001	24	3
15100201-001	19	1	15312433-002	24	3
15100201-002	19	1	15312438	23	3
15108406-001	3	14	15312439-001	23	4
15108406-002	3	14	15312439-002	23	4
15120642	35	4	15312470	29	5
	35	7	1532285	31	12
	35	13	15520603	15	24
15120662	5	7	15520604	15	25
	6	2	15520804	15	30
	15	13	15522003-001	15	34
	22	4	15522003-002	15	34
	22	9	15700210-001	15	1
15121054	7	2	15700210-002	15	1
	7	6	15700211-001	15	11
	7	11	15700211-002	15	11
	7	16	15700212-001	15	2
	15	19	15700212-002	15	2
	15	27	15700401-001	4	2
	15	33		16	2
15121055	8	5			

PART NUMBER	FIG.	ITEM	PART NUMBER	FIG.	ITEM
15700401-002	4	2	16501304	14	7
	16	2	16501350-001	14	1
1-585809	19	2	16501350-002	14	1
15940107	12	12	16501401-001	32	3
16050132	15	3	16501401-002	32	3
16210014-001	14	5	16501402	31	3
16210014-002	14	5	16501406-001	31	1
1626K7	29	4	16501406-002	31	1
16500250-001	4	1	16501450-001	32	1
	16	1	16501450-002	32	1
16500250-002	4	1	16501453-001	31	2
	16	1	16501453-002	31	2
16500251-001	16	4	16501455-001	31	6
16500251-002	16	4	16501455-002	31	6
16500252-001	4	4	16501456-001	31	4
16500252-002	4	4	16501456-002	31	4
16500312	15	20	16501460	32	4
	15	28	16501462	32	2
	15	32	16501604	9	24
16500334-001	15	15	16501605	9	23
16500334-002	15	15	16501606	7	9
16500336-001	15	12	16501607	7	14
16500336-002	15	12	16501609	17	7
16500451-001	4	9	16501610	9	26
	16	9	16501613	7	4
16500451-002	4	9		7	8
	16	9		7	13
16500553	8	1		9	16
16500554	8	6		9	19
16500604	29	6	16501800-001	33	1
16500652	29	1	16501800-002	33	1
16500653	30	1	16501818-001	12	21
16500654	30	2	16501818-002	12	21
16500655	30	7	16501820	33	8
16500656	30	4	16501822	35	2
16500903	13	5		35	11
16500905	13	7	16501832	12	25
16500907	13	11	16501833	33	9
16500950	13	6	16501857	33	7
16500954-001	13	2	16501860	34	2
16500954-002	13	2		34	6
16500955	13	8		34	10
16501050-001	22	6		34	13
16501050-002	22	6		34	16
16501051-001	22	1		34	20
16501051-002	22	1		34	23
16501053	22	2		34	27
	22	7		34	31
16501289-001	6	1		34	34
16501289-002	6	1		34	37

PART NUMBER	FIG.	ITEM	PART NUMBER	FIG.	ITEM
16501860	34	41	16501885-001	34	33
	35	1	16501885-002	34	33
16501861-001	2	2	16501886-001	34	26
16501861-001	2	8	16501886-002	34	26
16501861-001	11	2	16501887-001	12	19
	11	8	16501887-002	12	19
16501861-002	2	2	16501888-001	33	2
	2	8	16501888-002	33	2
	11	2	16501891-001	34	19
	11	8	16501891-002	34	19
16501862-001	5	2	16501892-001	34	9
16501862-002	5	2	16501892-002	34	9
16501863-001	5	1	16501893-001	34	1
16501863-002	5	1	16501893-002	34	1
16501866-001	5	6	16501894-001	34	15
16501866-002	5	6	16501894-002	34	15
16501867-001	3	25	16501895-001	34	12
16501867-002	3	25	16501895-002	34	12
16501870-001	33	3	16501896-001	34	5
16501870-002	33	3	16501896-002	34	5
16501873	34	3	16501897-001	12	18
	34	7	16501897-002	12	18
	34	11	16502050-001	7	5
	34	17	16502050-002	7	5
	34	21	16502056-001	7	10
	34	24	16502056-002	7	10
	34	28	16502300-001	15	29
	34	32	16502300-002	15	29
	34	38	16502400-001	15	23
	34	42	16502400-002	15	23
	35	6	16502502-001	24	2
16501874	34	4	16502502-002	24	2
	34	8	16502503	24	5
	34	14	16502504	23	5
	34	18	16502505-001	23	2
	34	25	16502505-002	23	2
	34	29	16502506-001	23	12
	34	35	16502506-002	23	12
	34	39	16502507-001	23	19
	35	10	16502507-002	23	19
16501877-001	3	30	16502552-001	24	1
16501877-002	3	30	16502552-002	24	1
16501881-001	34	30	16502553-001	23	1
16501881-002	34	30	16502553-002	23	1
16501882-001	34	40	16502554-001	23	11
16501882-002	34	40	16502554-002	23	11
16501883-001	34	22	16502555-001	23	19
16501883-002	34	22	16502555-002	23	19
16501884-001	34	36	16502556	26	1
16501884-002	34	36	16502557	28	1

PART NUMBER	FIG.	ITEM	PART NUMBER	FIG.	ITEM
16502558	25	1	16503559-002	10	1
16502655	33	5		18	1
16502657-001	33	4	16503560-001	10	15
16502657-002	33	4		18	15
16502689-001	33	10	16503560-002	10	15
16502689-002	33	10		18	15
16502834-001	3	20	16503561-001	10	5
	12	7		10	19
16502834-002	3	20	16503561-001	18	5
	12	7		18	19
16502835-001	3	22	16503561-002	10	5
16502835-002	3	22		10	19
16502844-001	21	9	16503561-002	18	5
16502844-002	21	9		18	19
16502853	21	5	16503562-001	10	13
16502854	21	6		10	27
16503050-001	9	1		18	13
16503050-002	9	1		18	27
16503150-001	9	17	16503562-002	10	13
16503150-002	9	17		10	27
16503250-001	7	1		18	13
16503250-002	7	1		18	27
16503454-001	20	4	16503563-001	10	10
	21	1		10	24
16503454-002	20	4		18	10
	21	1		18	24
16503455-001	21	8	16503563-002	10	10
16503455-002	21	8		10	24
16503457-001	21	7		18	10
16503457-002	21	7		18	24
16503458-001	21	10	16503572-001	10	29
16503458-002	21	10	16503572-002	10	29
16503459-001	21	13	16503573-001	10	30
16503459-002	21	13	16503573-002	10	30
16503521	10	14	16503611	15	18
	10	28	16503612	15	17
	18	14	1650364-002	15	22
	18	28	16503650-001	15	16
16503544	9	3	16503650-002	15	16
	9	8	16503654-001	15	22
	9	12	16503718-001	15	8
	9	20	16503718-002	15	8
	17	3	16503754-001	18	29
16503549	9	4	16503754-002	18	29
	9	9	16503766-001	15	7
	9	13	16503766-002	15	7
	9	21	16504253	3	34
	17	4		12	14
16503559-001	10	1	16504255	12	17
	18	1	16504256	3	35

PART NUMBER	FIG.	ITEM	PART NUMBER	FIG.	ITEM
16504705	7	17	16507022	12	8
16504750-001	7	15	1F406	29	3
16504750-002	7	15	1FD35	27	1
16504850-001	9	6	2M014	2	3
16504850-002	9	6		2	9
16504950-001	9	11		4	5
16504950-002	9	11		5	3
16505501-001	3	1		11	3
16505501-002	3	1		11	9
16505502-001	3	2		16	5
16505502-002	3	2	2M498	3	15
16505503-001	3	3		3	18
16505503-002	3	3		3	26
16505504-001	3	4		3	31
16505504-002	3	4		12	22
16505505-001	12	1	2V033	24	6
16505505-002	12	1	2V102	21	12
16505506-001	12	2	2V106	2	4
16505506-002	12	2		2	10
16505507-001	3	8		4	7
16505507-002	3	8		5	5
16505508-001	3	7		11	4
16505508-002	3	7		11	10
16505509-001	3	6		14	3
16505509-002	3	6		16	7
16505510-001	3	5		16	11
16505510-002	3	5	2V112	21	3
16505511-001	12	4	2X672	10	6
16505511-002	12	4		10	20
16505512-001	12	3		18	6
16505512-002	12	3		18	20
16505513	3	9	3259T19	2	6
16505514	3	12		2	12
16505515	3	10		4	8
16505516	3	11		11	6
16505517	12	5		11	12
16505518	12	6		16	8
16505543	3	17	3648T73	9	27
16505543	12	9		17	8
16505544-001	3	24	3712T23	12	13
16505544-002	3	24	3896T2	31	14
16505545-001	3	13	3H424	8	2
16505545-002	3	13		8	7
16505546-001	3	29		10	2
16505546-002	3	29		10	16
16505548-001	12	20		18	2
16505548-002	12	20		18	16
16506750-001	17	1	4J199	3	37
16506750-002	17	1		12	16
16507022	3	21	4KH26	31	15

PART NUMBER	FIG.	ITEM	PART NUMBER	FIG.	ITEM
4P251	15	4	4Y114	9	10
4P263	19	5			
4P270	21	11		9	22
4P286	4	10		17	5
	14	2	4YF24	15	10
	16	10		30	3
4P432	15	6	586552	9	29
	15	9		17	10
4P433	19	3	5D733	23	6
4P434	3	16	5W578	23	10
	3	19		25	7
	3	28		26	5
	3	33	700 ZN	3	23
	10	9		9	2
	10	23		9	7
	12	11		17	2
	12	24	74010903	31	5
	18	9		31	7
	18	23	808167	31	11
4P503	8	3	90170A650	35	5
	8	8		35	9
	10	4		35	14
	10	18	90177A217	13	10
	18	4		35	3
	18	18		35	8
4P529	15	5		35	12
4P530	8	4	90195A540	30	5
	8	9	90295A170	10	8
	10	3		10	22
	10	17		18	8
	18	3		18	22
	18	17	90480A006	23	16
4P531	3	27		23	24
	3	32	90692A762	13	4
	12	23	91102A725	23	17
4P533	2	5		23	25
	2	11	9113874	4	11
	4	6	91794A128	23	18
	5	4		23	23
	10	7	92005A215	24	7
	10	21	92390A271	10	12
	11	5		10	26
	11	11		18	12
	14	4		18	26
	16	6	92620A839	21	2
	18	7	9381T24	31	8
	18	21	94709A318	19	4
4P535	21	4	94800A720	30	6
4P799	14	6	971431650	22	3
4Y114	9	5		22	8

PART NUMBER	FIG.	ITEM
980715	31	10
98335A065	5	8
	6	3
	15	14
	22	5
	22	10
AH6411BZN	7	3
	7	7
	7	12
	9	15
	9	18
ASH656972N	15	21
	15	26
	15	31
CAH2-3118-150	4	3
	16	3
E0500-069-2750	10	11
	10	25
	18	11
	18	25
G603CAM-00-000	9	30
	17	11
IW925	28	5
MIL-P-501	33	6
MS 3452W16-10S	23	21
MS25042-16DA	23	9
	25	6
	26	2
	28	2
MS25043	23	15
	23	22
MS25043-16DA	25	2
MS3452W16-10S	23	13
MS3452W16-11S	23	14
MS3456W16-10P	23	8
	25	5
	26	3
MS3456W16-10S	25	3
MS3456W16-11P	28	3
MS85049/11-118W	23	7
	25	4
	26	4
	28	4
N243-576	31	9

COMPONENTS OF END ITEM (COEI) LIST

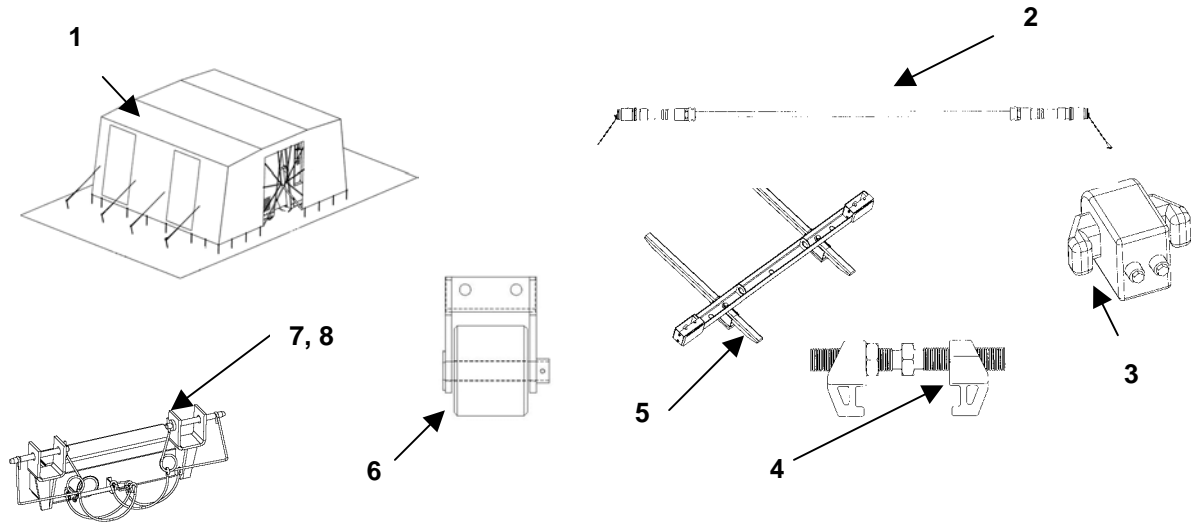

Table 1. Components of End Item List

(1) ILLUS NUMBER	(2) NATIONAL STOCK NUMBER	(3) DESCRIPTION, CAGEC, AND PART NUMBER	(4) USABLE ON CODE	(5) U/M	(6) QTY RQR
1		EPC ASSEMBLY, OD (1NSG3) 16501800-001	FTR, FTS	AY	1
		EPC ASSEMBLY, DS (1NSG3) 16501800-002	FTT, FTU	AY	1
2		CABLE 150 FT A/C (1NSG3) 16502558		EA	2
3		INTERCONNECTOR, HORIZONTAL (1NSG3) 15310101-001		EA	4
4		BRIDGE LOCK (1NSG3) 15312220		EA	2
5		LOAD RAIL CONNECTOR ASSEMBLY, OD (1NSG3) 16503454-001	FTR, FTS	AY	1
		LOAD RAIL CONNECTOR ASSEMBLY, DS (1NSG3) 16503454-002	FTT, FTU	AY	1
6		ROLLER ASSEMBLY, OD (1NSG3) 15310001-001	FTR, FTS	AY	2
6		ROLLER ASSEMBLY, DS (1NSG3) 15310001-002	FTT, FTU	AY	2
7		FORK POCKET ADAPTER CURB SIDE (1NSG3) 16501050-001	FTR, FTS	AY	1
		FORK POCKET ADAPTER CURB SIDE (1NSG3) 16501050-002		AY	1
8		FORK POCKET ADAPTER STREET SIDE (1NSG3) 16501051-001	FTR, FTS	AY	1
		FORK POCKET ADAPTER STREET SIDE (1NSG3) 16501051-002	FTT, FTU	AY	1

BASIC ISSUE ITEMS (BII) LIST

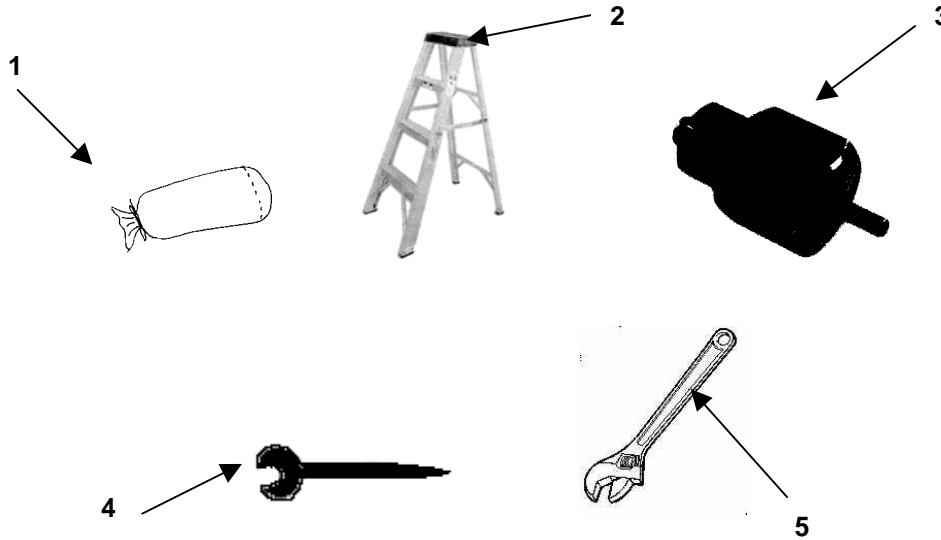

Table 2. Basic Issue Items List

(1) ILLUS NUMBER	(2) NATIONAL STOCK NUMBER	(3) DESCRIPTION, CAGEC, AND PART NUMBER	(4) USABLE ON CODE	(5) U/M	(6) QTY RQR
1		BASIC ISSUE ITEM BAG (1NSG3) 16503812-001		EA	1
1		BASIC ISSUE ITEM BAG (1NSG3) 16503812-002		EA	1
2	5440-01-415-1241	LADDER		EA	1
3		RIVET NUT TOOL 5/16 18 TPI (0VNM9) RNHT-3118		EA	1
4		WRENCH 1½-INCH OPEN STRUCTURAL RED FINISH (1NSG3) 15312904		EA	1
5		WRENCH, ADJUSTABLE, PREMIUM (1NSG3) 15312914		EA	1

**OPERATOR’S, UNIT AND DIRECT SUPPORT MAINTENANCE
 AUTHORIZED STOCKAGE LIST MOBILITY SYSTEM (ASLMS)**

- MODEL NUMBER FPU-8/12 PARTS (OD) P/N 15005002-001
 NSN 5411-01-523-2071**
- MODEL NUMBER FPU-8/12 PARTS (DS) P/N 15005002-002
 NSN 5411-01-523-2072**
- MODEL NUMBER FPU-8/12 BULK (OD) P/N 15005001-001
 NSN 5411-01-523-2073**
- MODEL NUMBER FPU-8/12 BULK (DS) P/N 15005001-002
 NSN 5411-01-523-2074**

ADDITIONAL AUTHORIZATION LIST (AAL)

INTRODUCTION

Scope

This work package lists additional items you are authorized for the support of the ASLMS.

General

This list identifies items that do not have to accompany the ASLMS and that do not have to be turned in with it. These items are all authorized to you by CTA, MTOE, TDA, or JTA.

Explanation of Columns in the AAL

Column (1) – National Stock Number (NSN). Identifies the stock number of the item to be used for requisitioning purposes.

Column (2) – Description, Commercial and Government Entity Code (CAGEC), and Part Number (P/N). Identifies the Federal item name (in all capital letters) followed by a minimum description when needed. The last line below the description is the CAGEC (in parentheses) and the part number.

Column (3) – Usable On Code. When applicable, gives you a code if the item you need is not the same for different models of equipment.

<u>Code</u>	<u>Used on</u>
FTR	FPU-8/12 PARTS OD
FTS	FPU-8/12 BULK OD
FTT	FPU-8/12 PARTS DS
FTU	FPU-8/12 BULK DS

Column (4) – Unit of Measure (U/M). Indicates the physical measurement or count of the item as issued per the National Stock Number (NSN) shown in column (1).

Column (5) – Qty Recm. Indicates the quantity recommended.

ADDITIONAL AUTHORIZATION LIST (AAL)

Table 1. Additional Authorization List

(1) NATIONAL STOCK NUMBER	(2) DESCRIPTION, CAGEC, AND PART NUMBER	(3) USABLE ON CODE	(4) U/M	(5) QTY RECM
6150-01-307-9446	PDISE, M40 (97403) TA13229E6353		EA	1
5975-00-019-8827	ROD GROUND (80063) SC-DL-75591		EA	1
8340-00-262-5767	REPAIR KIT, TENTAGE (81349) MIL-C-3372		EA	1

OPERATOR'S, UNIT AND DIRECT SUPPORT MAINTENANCE**AUTHORIZED STOCKAGE LIST MOBILITY SYSTEM (ASLMS)****MODEL NUMBER FPU-8/12 PARTS (OD) P/N 15005002-001****NSN 5411-01-523-2071****MODEL NUMBER FPU-8/12 PARTS (DS) P/N 15005002-002****NSN 5411-01-523-2072****MODEL NUMBER FPU-8/12 BULK (OD) P/N 15005001-001****NSN 5411-01-523-2073****MODEL NUMBER FPU-8/12 BULK (DS) P/N 15005001-002****NSN 5411-01-523-2074**

EXPENDABLE AND DURABLE ITEMS LIST

INTRODUCTION**Scope**

This work package lists expendable and durable items that you will need to operate and maintain the ASLMS. This list is for information only and is not authority to requisition the listed items. These items are authorized to you by CTA 50-970, Expendable/Durable Items (Except Medical, Class V Repair Parts, and Heraldic Items), or CTA 8-100, Army Medical Department Expendable/Durable Items.

Explanation of Columns in the Expendable/Durable Items List

Column (1) – Item Number. This number is assigned to the entry in the list and is referenced in the narrative instructions to identify the item (e.g., “Use brake fluid (item 5, WP 0098 00).”)

Column (2) – Level. This column identifies the lowest level of maintenance that requires the listed item (C = Operator/Crew).

Column (3) – National Stock Number (NSN). This is the NSN assigned to the item which you can use to requisition it.

Column (4) – Item Name, Description, Commercial and Government Entity Code (CAGE), and Part Number (P/N). This column provides the other information you need to identify the item.

Column (5) – Unit of Measure (U/M). This code shows the physical measurement or count of an item, such as gallon, dozen, gross, etc.

Table 1. Expendable and Durable Items List

(1) ITEM NUMBER	(2) LEVEL	(3) NATIONAL STOCK NUMBER	(4) ITEM NAME, DESCRIPTION, CAGE, PART NUMBER	(5) U/M
1	C	7930-00-558-111	Detergent, General Purpose	GAL
2		5970-00-441-8629	Electrical Tape	RL
3	C		Gloves, Latex – Nitrile (55799) 695458	BX
4	C	7050-00-961-7662	Grease, Molycote	TU
5	C	8030-01-142-3131	Loctite 262 Red	BT
6	C	9150-00-263-3490	Oil, General Purpose, Lubricating	GAL
7	C	8010-00-111-8004	Paint CARC, Color, DS	GAL
7	C	8010-00-111-8069	Paint CARC, Color, OD	GAL
8	C	7920-00-205-1711	Rags	BD
9		9950-00-537-8954	Wire Tags	BD

END OF WORK PACKAGE

These are the instructions for sending an electronic 2028

The following format must be used if submitting an electronic 2028. The subject line must be exactly the same and all fields must be included; however, only the following fields are mandatory: 1, 3, 4, 5, 6, 7, 8, 9, 10, 13, 15, 16, 17, and 27.

From: "Whomever" whomever@avma27.army.mil

To: amssbriml@natick.army.mil

Subject: DA Form 2028

1. **From:** Joe Smith
2. **Unit** home
3. **Address:** 4300 Park
4. **City:** Hometown
5. **St:** MO
6. **Zip:** 77777
7. **Date Sent:** 19-OCT-93
8. **Pub no:** 55-2840-229-23
9. **Pub Title:** TM
10. **Publication Date:** 04-JUL-85
11. **Change Number:** 7
12. **Submitter Rank:** MSG
13. **Submitter FName:** Joe
14. **Submitter MName:** T
15. **Submitter LName:** Smith
16. **Submitter Phone:** 123-123-1234
17. **Problem:** 1
18. **Page:** 2
19. **Paragraph:** 3
20. **Line:** 4
21. **NSN:** 5
22. **Reference:** 6
23. **Figure:** 7
24. **Table:** 8
25. **Item:** 9
26. **Total:** 123
27. **Text:**

This is the text for the problem below line 27.

RECOMMENDED CHANGES TO PUBLICATIONS AND BLANK FORMS For use of this form, see AR 25-30; the proponent agency is ODISC4.						Use Part II (reverse) for Repair Parts and Special Tool Lists (RPSTL) and Supply Catalogs/Supply Manuals (SC/SM).	DATE 21 October 2003
TO: (Forward to proponent of publication or form) (Include ZIP Code) COMMANDER U.S. ARMY TANK-AUTOMOTIVE AND ARMAMENT COMMAND ATTN: AMSTA-LC-CECT 15 KANSAS STREET NATICK, MA 01760-5052						FROM: (Activity and location) (Include ZIP Code) <i>PFC Jane Doe</i> <i>CO A 3rd Engineer BR</i> <i>Ft. Leonardwood, MO 63108</i>	
PART I – ALL PUBLICATIONS (EXCEPT RPSTL AND SC/SM) AND BLANK FORMS							
PUBLICATION/FORM NUMBER TM 10-1670-296-23&P				DATE 30 October 2002		TITLE Unit Manual for Ancillary Equipment for Low Velocity Air Drop Systems	
ITEM NO.	PAGE NO.	PARA-GRAPH	LINE NO. *	FIGURE NO.	TABLE NO.	RECOMMENDED CHANGES AND REASON <i>(Provide exact wording of recommended changes, if possible).</i>	
	0036 00-2				1	<i>In table 1, Sewing Machine Code Symbols, the second sewing machine code symbol should be MD ZZ not MD 22.</i> <i>Change the manual to show Sewing Machine, Industrial: Zig-Zag; 308 stitch; medium-duty; NSN 3530-01-181-1421 as a MD ZZ code symbol.</i>	
<small>*Reference to line numbers within the paragraph or subparagraph.</small>							
TYPED NAME, GRADE OR TITLE Jane Doe, PFC				TELEPHONE EXCHANGE/AUTOVON, PLUS EXTENSION 508-233-4141		SIGNATURE Jane Doe <i>Jane Doe</i>	

TO: <i>(Forward direct to addressee listed in publication)</i> COMMANDER U.S. ARMY TANK-AUTOMOTIVE AND ARMAMENT COMMAND ATTN: AMSTA-LC-CECT 15 KANSAS STREET NATICK, MA 01760-5052	FROM: <i>(Activity and location) (Include ZIP Code)</i> <i>PFC Jane Doe</i> <i>CO A 3rd Engineer BR</i> <i>Ft. Leonardwood, MO 63108</i>	DATE 21 October 2003
--	---	--------------------------------

PART II – REPAIR PARTS AND SPECIAL TOOL LISTS AND SUPPLY CATALOGS/SUPPLY MANUALS

PUBLICATION NUMBER TM 10-1670-296-23&P	DATE 30 October 2002	TITLE Unit Manual for Ancillary Equipment for Low Velocity Air Drop Systems
--	--------------------------------	---

PAGE NO.	COLM NO.	LINE NO.	NATIONAL STOCK NUMBER	REFERENCE NO.	FIGURE NO.	ITEM NO.	TOTAL NO. OF MAJOR ITEMS SUPPORTED	RECOMMENDED ACTION
0066 00-1					4			<i>Callout 16 in figure 4 is pointed to a <u>D-Ring</u>. In the Repair Parts List key for figure 4, item 16 is called a <u>Snap Hook</u>. Please correct one or the other.</i>

SAMPLE

PART III – REMARKS *(Any general remarks or recommendations, or suggestions for improvement of publications and blank forms. Additional blank sheets may be used if more space is needed.)*

TYPED NAME, GRADE OR TITLE	TELEPHONE EXCHANGE/AUTOVON, PLUS EXTENSION	SIGNATURE
----------------------------	--	-----------

<p align="center">RECOMMENDED CHANGES TO PUBLICATIONS AND BLANK FORMS</p> <p>For use of this form, see AR 25-30; the proponent agency is ODISC4.</p>						Use Part II (reverse) for Repair Parts and Special Tool Lists (RPSTL) and Supply Catalogs/Supply Manuals (SC/SM).	DATE
TO: (Forward to proponent of publication or form) (Include ZIP Code) COMMANDER U.S. ARMYTANK-AUTOMOTIVE AND ARMAMENT COMMAND ATTN: AMSTA-LC-CECT 15 KANSAS STREET NATICK, MA 01760-5052						FROM: (Activity and location) (Include ZIP Code)	
PART I – ALL PUBLICATIONS (EXCEPT RPSTL AND SC/SM) AND BLANK FORMS							
PUBLICATION/FORM NUMBER TM 10-5411-236-13&P				DATE 28 February 2005	TITLE Authorized Stockage List Mobility System (ASLMS)		
ITEM NO.	PAGE NO.	PARA-GRAPH	LINE NO. *	FIGURE NO.	TABLE NO.	RECOMMENDED CHANGES AND REASON <i>(Provide exact wording of recommended changes, if possible).</i>	
*Reference to line numbers within the paragraph or subparagraph.							
TYPED NAME, GRADE OR TITLE				TELEPHONE EXCHANGE/AUTOVON, PLUS EXTENSION		SIGNATURE	

TO: <i>(Forward direct to addressee listed in publication)</i> COMMANDER U.S. ARMYTANK-AUTOMOTIVE AND ARMAMENT COMMAND ATTN: AMSTA-LC-CECT 15 KANSAS STREET NATICK, MA 01760-5052	FROM: <i>(Activity and location) (Include ZIP Code)</i>	DATE
---	--	-------------

PART II – REPAIR PARTS AND SPECIAL TOOL LISTS AND SUPPLY CATALOGS/SUPPLY MANUALS

PUBLICATION NUMBER TM 10-5411-236-13&P				DATE 28 February 2005			TITLE Authorized Stockage List Mobility System (ASLMS)	
PAGE NO.	COLM NO.	LINE NO.	NATIONAL STOCK NUMBER	REFERENCE NO.	FIGURE NO.	ITEM NO.	TOTAL NO. OF MAJOR ITEMS SUPPORTED	RECOMMENDED ACTION

PART III – REMARKS *(Any general remarks or recommendations, or suggestions for improvement of publications and blank forms. Additional blank sheets may be used if more space is needed.)*

TYPED NAME, GRADE OR TITLE	TELEPHONE EXCHANGE/AUTOVON, PLUS EXTENSION	SIGNATURE
----------------------------	--	-----------

RECOMMENDED CHANGES TO PUBLICATIONS AND BLANK FORMS						Use Part II (reverse) for Repair Parts and Special Tool Lists (RPSTL) and Supply Catalogs/Supply Manuals (SC/SM).	DATE
For use of this form, see AR 25-30; the proponent agency is ODISC4.							
TO: (Forward to proponent of publication or form) (Include ZIP Code) COMMANDER U.S. ARMYTANK-AUTOMOTIVE AND ARMAMENT COMMAND ATTN: AMSTA-LC-CECT 15 KANSAS STREET NATICK, MA 01760-5052						FROM: (Activity and location) (Include ZIP Code)	
PART I – ALL PUBLICATIONS (EXCEPT RPSTL AND SC/SM) AND BLANK FORMS							
PUBLICATION/FORM NUMBER TM 10-5411-236-13&P				DATE 28 February 2005		TITLE Authorized Stockage List Mobility System (ASLMS)	
ITEM NO.	PAGE NO.	PARA-GRAPH	LINE NO. *	FIGURE NO.	TABLE NO.	RECOMMENDED CHANGES AND REASON <i>(Provide exact wording of recommended changes, if possible).</i>	
<i>*Reference to line numbers within the paragraph or subparagraph.</i>							
TYPED NAME, GRADE OR TITLE				TELEPHONE EXCHANGE/AUTOVON, PLUS EXTENSION		SIGNATURE	

TO: <i>(Forward direct to addressee listed in publication)</i> COMMANDER U.S. ARMYTANK-AUTOMOTIVE AND ARMAMENT COMMAND ATTN: AMSTA-LC-CECT 15 KANSAS STREET NATICK, MA 01760-5052	FROM: <i>(Activity and location) (Include ZIP Code)</i>	DATE
---	--	-------------

PART II – REPAIR PARTS AND SPECIAL TOOL LISTS AND SUPPLY CATALOGS/SUPPLY MANUALS

PUBLICATION NUMBER TM 10-5411-236-13&P				DATE 28 February 2005			TITLE Authorized Stockage List Mobility System (ASLMS)	
PAGE NO.	COLM NO.	LINE NO.	NATIONAL STOCK NUMBER	REFERENCE NO.	FIGURE NO.	ITEM NO.	TOTAL NO. OF MAJOR ITEMS SUPPORTED	RECOMMENDED ACTION

PART III – REMARKS *(Any general remarks or recommendations, or suggestions for improvement of publications and blank forms. Additional blank sheets may be used if more space is needed.)*

TYPED NAME, GRADE OR TITLE	TELEPHONE EXCHANGE/AUTOVON, PLUS EXTENSION	SIGNATURE
----------------------------	--	-----------

<p align="center">RECOMMENDED CHANGES TO PUBLICATIONS AND BLANK FORMS</p> <p>For use of this form, see AR 25-30; the proponent agency is ODISC4.</p>						Use Part II (reverse) for Repair Parts and Special Tool Lists (RPSTL) and Supply Catalogs/Supply Manuals (SC/SM).	DATE
TO: (Forward to proponent of publication or form) (Include ZIP Code) COMMANDER U.S. ARMYTANK-AUTOMOTIVE AND ARMAMENT COMMAND ATTN: AMSTA-LC-CECT 15 KANSAS STREET NATICK, MA 01760-5052						FROM: (Activity and location) (Include ZIP Code)	
PART I – ALL PUBLICATIONS (EXCEPT RPSTL AND SC/SM) AND BLANK FORMS							
PUBLICATION/FORM NUMBER TM 10-5411-236-13&P				DATE 28 February 2005	TITLE Authorized Stockage List Mobility System (ASLMS)		
ITEM NO.	PAGE NO.	PARA-GRAPH	LINE NO. *	FIGURE NO.	TABLE NO.	RECOMMENDED CHANGES AND REASON <i>(Provide exact wording of recommended changes, if possible).</i>	
*Reference to line numbers within the paragraph or subparagraph.							
TYPED NAME, GRADE OR TITLE				TELEPHONE EXCHANGE/AUTOVON, PLUS EXTENSION		SIGNATURE	

TO: <i>(Forward direct to addressee listed in publication)</i> COMMANDER U.S. ARMYTANK-AUTOMOTIVE AND ARMAMENT COMMAND ATTN: AMSTA-LC-CECT 15 KANSAS STREET NATICK, MA 01760-5052	FROM: <i>(Activity and location) (Include ZIP Code)</i>	DATE
---	--	-------------

PART II – REPAIR PARTS AND SPECIAL TOOL LISTS AND SUPPLY CATALOGS/SUPPLY MANUALS

PUBLICATION NUMBER TM 10-5411-236-13&P				DATE 28 February 2005			TITLE Authorized Stockage List Mobility System (ASLMS)	
PAGE NO.	COLM NO.	LINE NO.	NATIONAL STOCK NUMBER	REFERENCE NO.	FIGURE NO.	ITEM NO.	TOTAL NO. OF MAJOR ITEMS SUPPORTED	RECOMMENDED ACTION

PART III – REMARKS *(Any general remarks or recommendations, or suggestions for improvement of publications and blank forms. Additional blank sheets may be used if more space is needed.)*

TYPED NAME, GRADE OR TITLE	TELEPHONE EXCHANGE/AUTOVON, PLUS EXTENSION	SIGNATURE
----------------------------	--	-----------

The Metric System and Equivalents

Linear Measure

1 centimeter = 10 millimeters = .39 inch
 1 decimeter = 10 centimeters = 3.94 inches
 1 meter = 10 decimeters = 39.37 inches
 1 dekameter = 10 meters = 32.8 feet
 1 hectometer = 10 dekameters = 328.08 feet
 1 kilometer = 10 hectometers = 3,280.8 feet

Weights

1 centigram = 10 milligrams = .15 grain
 1 decigram = 10 centigrams = 1.54 grains
 1 gram = 10 decigrams = .035 ounce
 1 dekagram = 10 grams = .35 ounce
 1 hectogram = 10 dekagrams = 3.52 ounces
 1 kilogram = 10 hectograms = 2.2 pounds
 1 quintal = 100 kilograms = 220.46 pounds
 1 metric ton = 10 quintals = 1.1 short tons

Liquid Measure

1 centiliter = 10 milliliters = .34 fl. ounce
 1 deciliter = 10 centiliters = 3.38 fl. ounces
 1 liter = 10 deciliters = 33.81 fl. ounces
 1 dekaliter = 10 liters = 2.64 gallons
 1 hectoliter = 10 dekaliters = 26.42 gallons
 1 kiloliter = 10 hectoliters = 264.18 gallons

Square Measure

1 sq. centimeter = 100 sq. millimeters = .155 sq. inch
 1 sq. decimeter = 100 sq. centimeters = 15.5 sq. inches
 1 sq. meter (centare) = 100 sq. decimeters = 10.76 sq. feet
 1 sq. dekameter (are) = 100 sq. meters = 1,076.4 sq. feet
 1 sq. hectometer (hectare) = 100 sq. dekameters = 2.47 acres
 1 sq. kilometer = 100 sq. hectometers = .386 sq. mile

Cubic Measure

1 cu. centimeter = 1000 cu. millimeters = .06 cu. inch
 1 cu. decimeter = 1000 cu. centimeters = 61.02 cu. inches
 1 cu. meter = 1000 cu. decimeters = 35.31 feet

Approximate Conversion Factors

<i>To change</i>	<i>To</i>	<i>Multiply by</i>	<i>To change</i>	<i>To</i>	<i>Multiply by</i>
inches	centimeters	2.540	ounce-inches	newton-meters	.007062
feet	meters	.305	centimeters	inches	.394
yards	meters	.914	meters	feet	3.280
miles	kilometers	1.609	meters	yards	1.094
square inches	square centimeters	6.451	kilometers	miles	.621
square feet	square meters	.093	square centimeters	square inches	.155
square yards	square meters	.836	square meters	square feet	10.764
square miles	square kilometers	2.590	square meters	square yards	1.196
acres	square hectometers	.405	square kilometers	square miles	.386
cubic feet	cubic meters	.028	square hectometers	acres	2.471
cubic yards	cubic meters	.765	cubic meters	cubic feet	35.315
fluid ounces	milliliters	29.573	cubic meters	cubic yards	1.308
pints	liters	.473	milliliters	fluid ounces	.034
quarts	liters	.946	liters	pints	2.113
gallons	liters	3.785	liters	quarts	1.057
ounces	grams	28.349	liters	gallons	.264
pounds	kilograms	.454	grams	ounces	.035
short tons	metric tons	.907	kilograms	pounds	2.205
pound-feet	newton-meters	1.356	metric tons	short tons	1.102
pound-inches	newton-meters	.11296			

Temperature (Exact)

 °F Fahrenheit temperature $\times \frac{5}{9}$ (after subtracting 32) = Celsius temperature °C

PIN: 082261-000